

MULTIPLE CHOICE. Choose the one alternative that best completes the statement or answers the question.

Find the average rate of change of the function over the given interval.

1) $y = x^2 + 2x$, $[3, 7]$ 1) _____
 A) $\frac{63}{4}$ B) $\frac{48}{7}$ C) 9 D) 12

2) $y = 4x^3 + 6x^2 - 3$, $[-6, 2]$ 2) _____
 A) $\frac{53}{8}$ B) $\frac{53}{2}$ C) 352 D) 88

3) $y = \sqrt{2x}$, $[2, 8]$ 3) _____
 A) $\frac{1}{3}$ B) 7 C) $-\frac{3}{10}$ D) 2

4) $y = \frac{3}{x-2}$, $[4, 7]$ 4) _____
 A) 2 B) 7 C) $\frac{1}{3}$ D) $-\frac{3}{10}$

5) $y = 4x^2$, $\left[0, \frac{7}{4}\right]$ 5) _____
 A) $-\frac{3}{10}$ B) 2 C) 7 D) $\frac{1}{3}$

6) $y = -3x^2 - x$, $[5, 6]$ 6) _____
 A) $\frac{1}{2}$ B) -2 C) -34 D) $-\frac{1}{6}$

7) $h(t) = \sin(3t)$, $\left[0, \frac{\pi}{6}\right]$ 7) _____
 A) $\frac{6}{\pi}$ B) $\frac{\pi}{6}$ C) $\frac{3}{\pi}$ D) $-\frac{6}{\pi}$

8) $g(t) = 3 + \tan t$, $\left[-\frac{\pi}{4}, \frac{\pi}{4}\right]$ 8) _____
 A) $-\frac{8}{5}$ B) 0 C) $\frac{4}{\pi}$ D) $-\frac{4}{\pi}$

Find the slope of the curve at the given point P and an equation of the tangent line at P.

9) $y = x^2 + 5x$, $P(4, 36)$ 9) _____
 A) slope is $\frac{1}{20}$; $y = \frac{x}{20} + \frac{1}{5}$ B) slope is 13; $y = 13x - 16$
 C) slope is -39; $y = -39x - 80$ D) slope is $-\frac{4}{25}$; $y = -\frac{4x}{25} + \frac{8}{5}$

10) $y = x^2 + 11x - 15$, $P(1, -3)$

A) slope is -39; $y = -39x - 80$

C) slope is 13; $y = 13x - 16$

B) slope is $-\frac{4}{25}$; $y = -\frac{4x}{25} + \frac{8}{5}$

D) slope is $\frac{1}{20}$; $y = \frac{x}{20} + \frac{1}{5}$

10) _____

11) $y = x^3 - 9x$, $P(1, -8)$

A) slope is 3; $y = 3x - 11$

C) slope is -6; $y = -6x$

B) slope is 3; $y = 3x - 7$

D) slope is -6; $y = -6x - 2$

11) _____

12) $y = x^3 - 3x^2 + 4$, $P(3, 4)$

A) slope is 0; $y = -23$

C) slope is 1; $y = x - 23$

B) slope is 9; $y = 9x + 4$

D) slope is 9; $y = 9x - 23$

12) _____

13) $y = -3 - x^3$, $(1, -4)$

A) slope is 0; $y = -1$

C) slope is 3; $y = 3x - 1$

B) slope is -3; $y = -3x - 1$

D) slope is -1; $y = -x - 1$

13) _____

Use the slopes of **UQ**, **UR**, **US**, and **UT** to estimate the rate of change of **y** at the specified value of **x**.

14) $x = 5$

14) _____

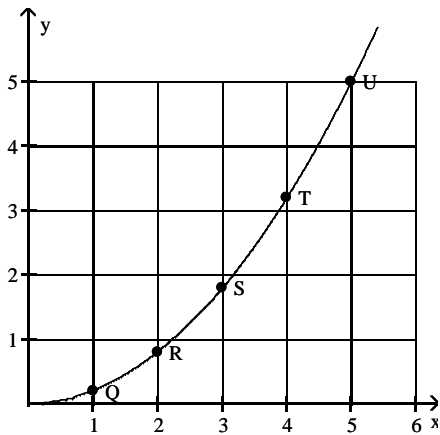

A) 2

B) 1

C) 5

D) 0

15) $x = 3$

15) _____

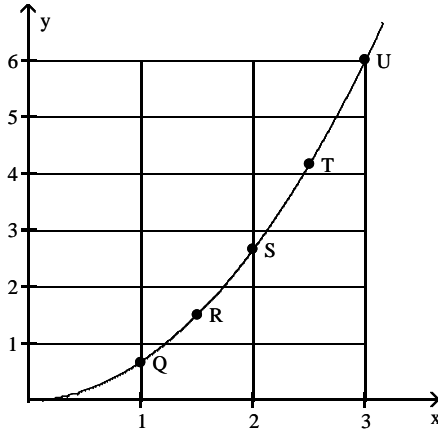

A) 6

B) 0

C) 2

D) 4

16) $x = 5$

16) _____

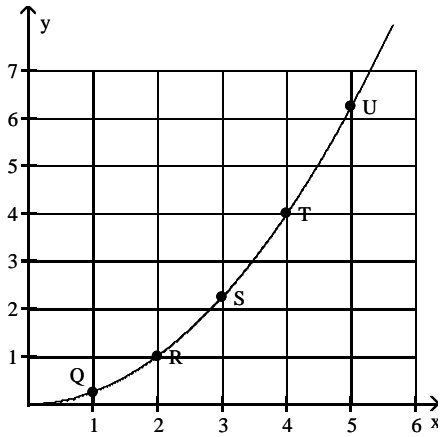

A) $\frac{25}{4}$

B) $\frac{5}{2}$

C) $\frac{5}{4}$

D) 0

17) $x = 2$

17) _____

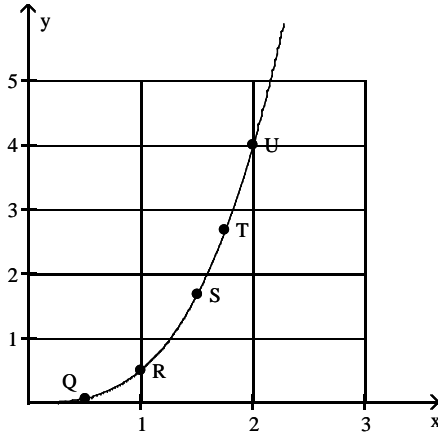

A) 3

B) 0

C) 6

D) 4

18) $x = 2.5$

18) _____

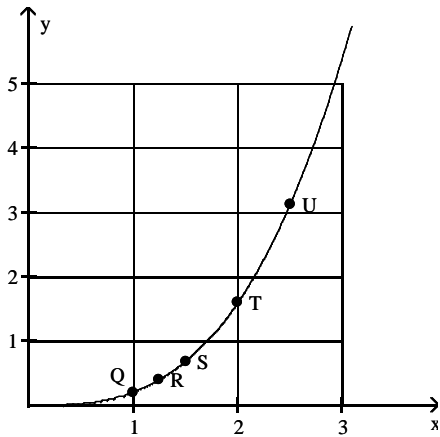

A) 7.5

B) 1.25

C) 0

D) 3.75

Use the table to estimate the rate of change of y at the specified value of x .

19) $x = 1$.

19) _____

x	y
0	0
0.2	0.02
0.4	0.08
0.6	0.18
0.8	0.32
1.0	0.5
1.2	0.72
1.4	0.98

A) 1.5

B) 2

C) 0.5

D) 1

20) $x = 1$.

20) _____

x	y
0	0
0.2	0.01
0.4	0.04
0.6	0.09
0.8	0.16
1.0	0.25
1.2	0.36
1.4	0.49

A) 2

B) 1.5

C) 1

D) 0.5

21) $x = 1$.

21) _____

x	y
0	0
0.2	0.12
0.4	0.48
0.6	1.08
0.8	1.92
1.0	3
1.2	4.32
1.4	5.88

A) 6

B) 8

C) 2

D) 4

22) $x = 2$.

22) _____

x	y
0	10
0.5	38
1.0	58
1.5	70
2.0	74
2.5	70
3.0	58
3.5	38
4.0	10

A) 4

B) -8

C) 8

D) 0

23) $x = 1$.

23) _____

x	y
0.900	-0.05263
0.990	-0.00503
0.999	-0.0005
1.000	0.0000
1.001	0.0005
1.010	0.00498
1.100	0.04762

A) 0.5

B) 0

C) 1

D) -0.5

Solve the problem.

24) When exposed to ethylene gas, green bananas will ripen at an accelerated rate. The number of days for ripening becomes shorter for longer exposure times. Assume that the table below gives average ripening times of bananas for several different ethylene exposure times:

24) _____

Exposure time (minutes)	Ripening Time (days)
10	4.2
15	3.5
20	2.6
25	2.1
30	1.1

Plot the data and then find a line approximating the data. With the aid of this line, find the limit of the average ripening time as the exposure time to ethylene approaches 0. Round your answer to the nearest tenth.

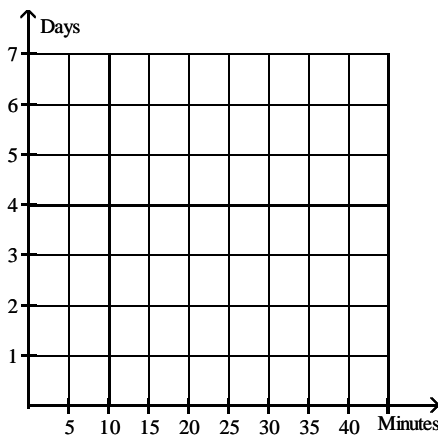

A)

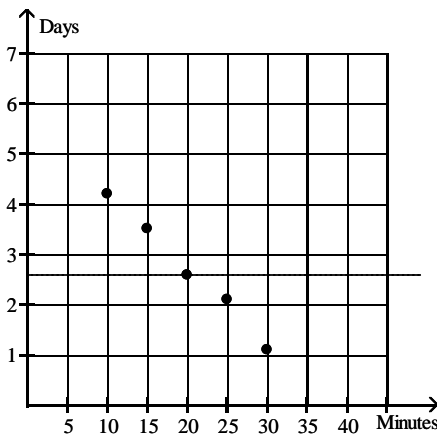

2.6 days

B)

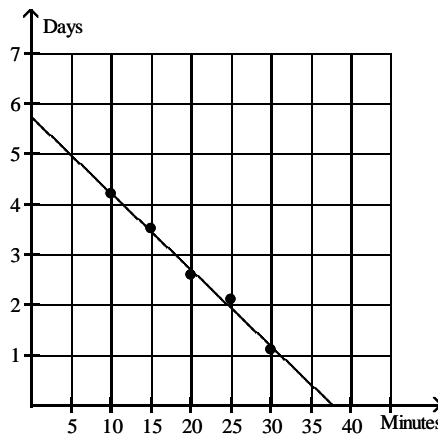

5.8 days

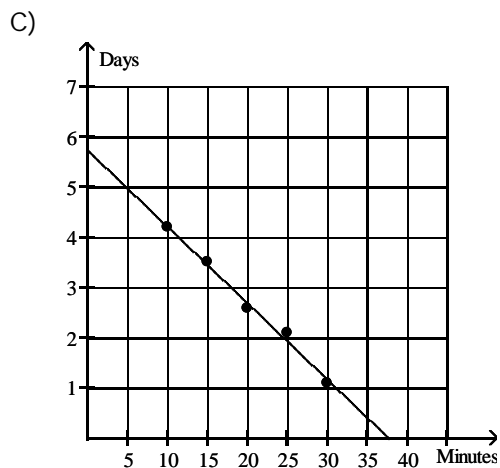

37.5 minutes

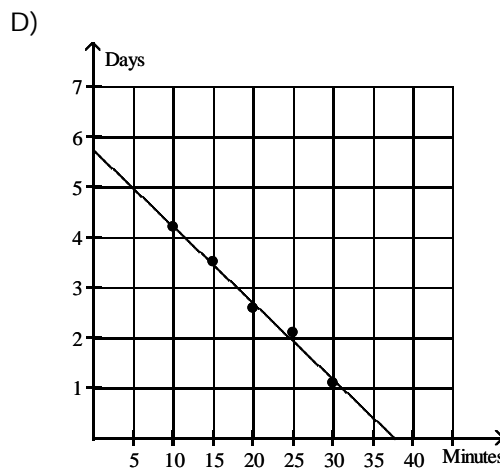

0.1 day

25) When exposed to ethylene gas, green bananas will ripen at an accelerated rate. The number of days for ripening becomes shorter for longer exposure times. Assume that the table below gives average ripening times of bananas for several different ethylene exposure times.

25) _____

Exposure time (minutes)	Ripening Time (days)
10	4.3
15	3.2
20	2.7
25	2.1
30	1.3

Plot the data and then find a line approximating the data. With the aid of this line, determine the rate of change of ripening time with respect to exposure time. Round your answer to two significant digits.

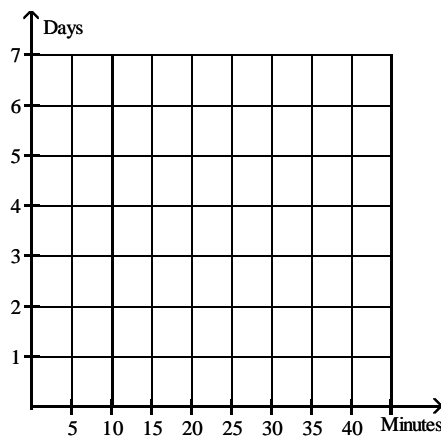

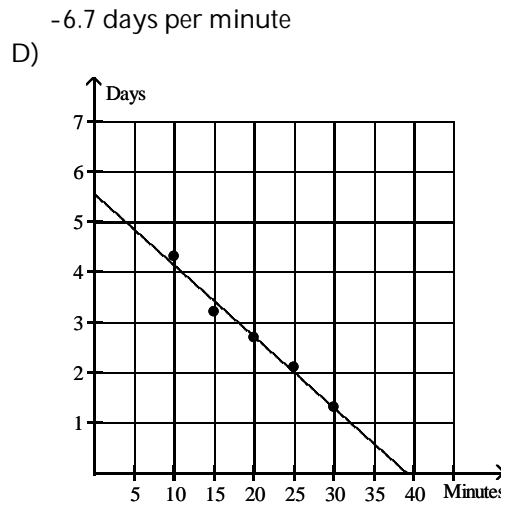
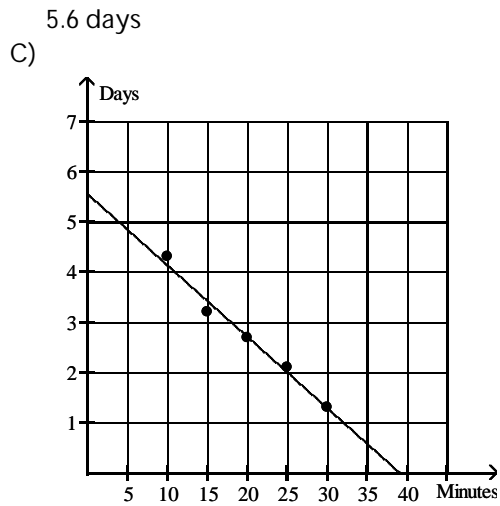
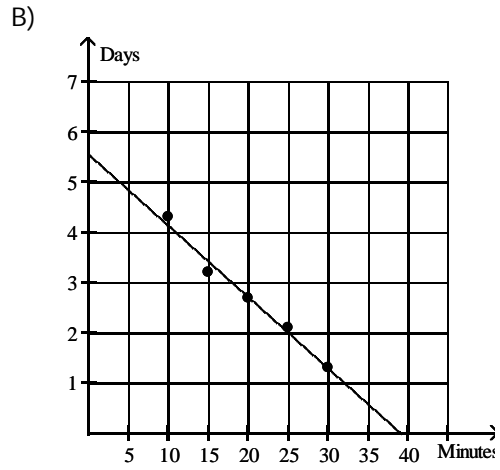
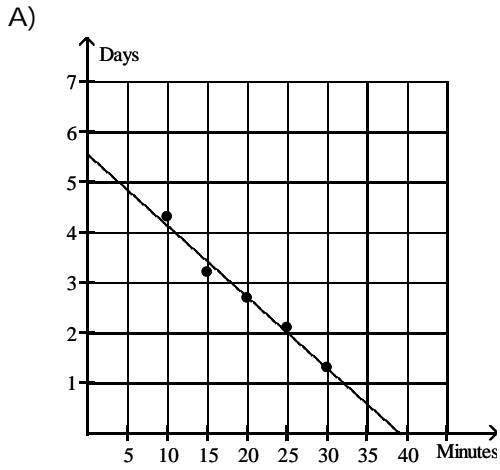

-0.14 day per minute

38 minutes

26) The graph below shows the number of tuberculosis deaths in the United States from 1989 to 1998. 26) _____

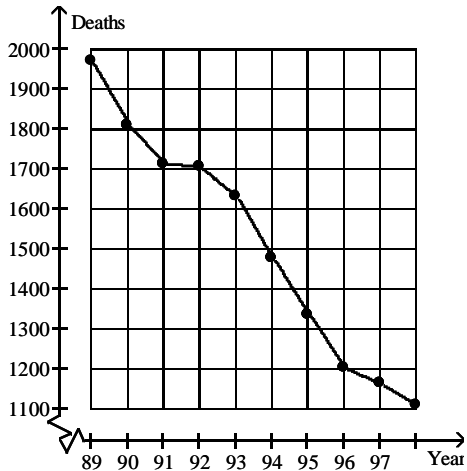

Estimate the average rate of change in tuberculosis deaths from 1991 to 1993.

- A) About -30 deaths per year
- B) About -45 deaths per year
- C) About -80 deaths per year
- D) About -0.4 deaths per year

Use the graph to evaluate the limit.

27) $\lim_{x \rightarrow -1} f(x)$

27) _____

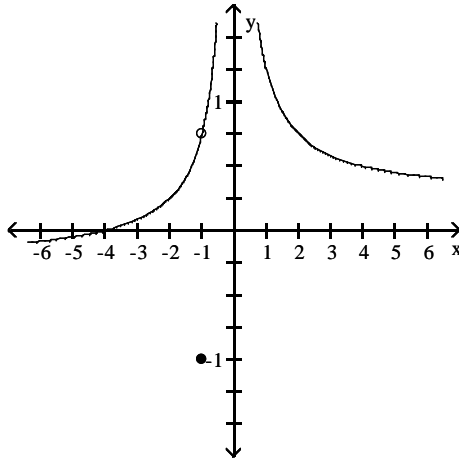

A) ∞

B) $-\frac{3}{4}$

C) $\frac{3}{4}$

D) -1

28) $\lim_{x \rightarrow 0} f(x)$

28) _____

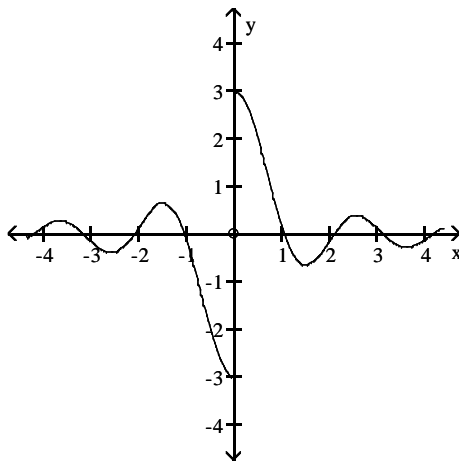

A) 3

B) 0

C) -3

D) does not exist

29) $\lim_{x \rightarrow 0} f(x)$

29) _____

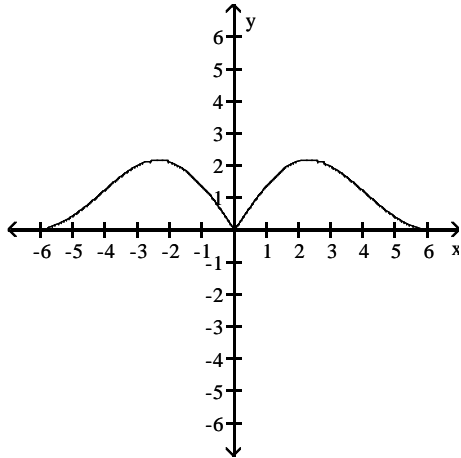

A) -3

B) 0

C) does not exist

D) 3

30) $\lim_{x \rightarrow 0} f(x)$

30) _____

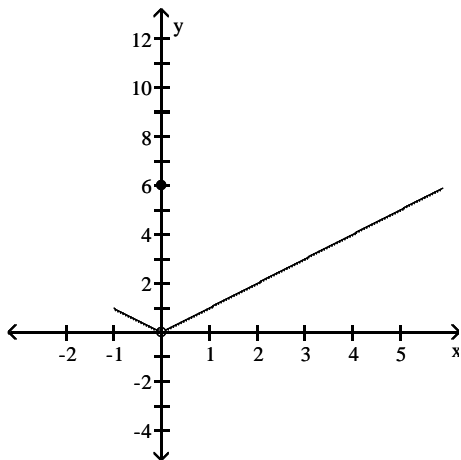

A) does not exist

B) -1

C) 0

D) 6

31) $\lim_{x \rightarrow 0} f(x)$

31) _____

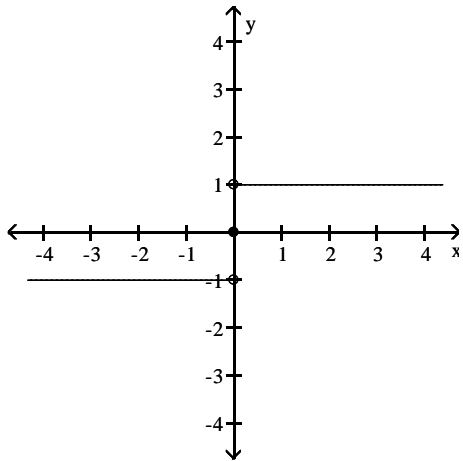

A) ∞

B) does not exist

C) 1

D) -1

32) $\lim_{x \rightarrow 0} f(x)$

32) _____

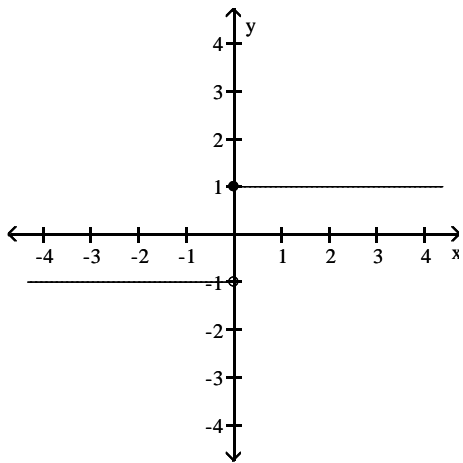

A) ∞

B) does not exist

C) 1

D) -1

33) $\lim_{x \rightarrow 0} f(x)$

33) _____

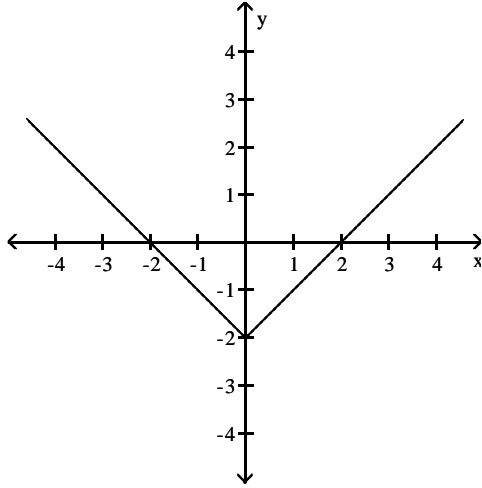

A) 0

B) -2

C) 2

D) does not exist

34) $\lim_{x \rightarrow 0} f(x)$

34) _____

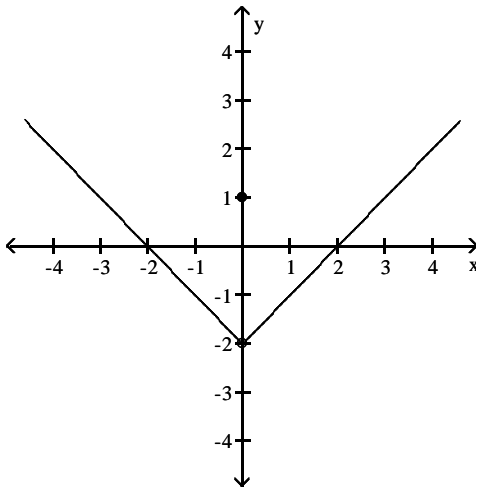

A) does not exist

B) -2

C) 0

D) 1

35) $\lim_{x \rightarrow 0} f(x)$

35) _____

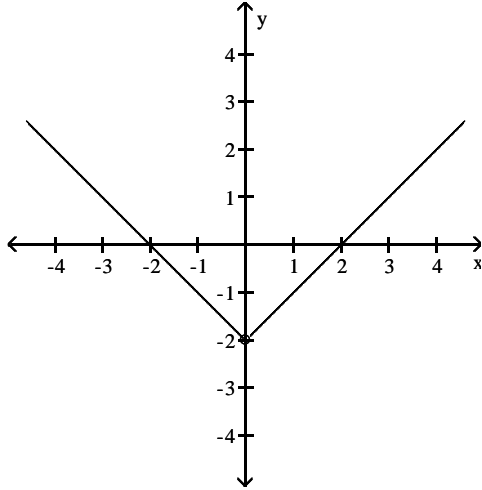

- A) does not exist B) 2 C) -1 D) -2

36) $\lim_{x \rightarrow 0} f(x)$

36) _____

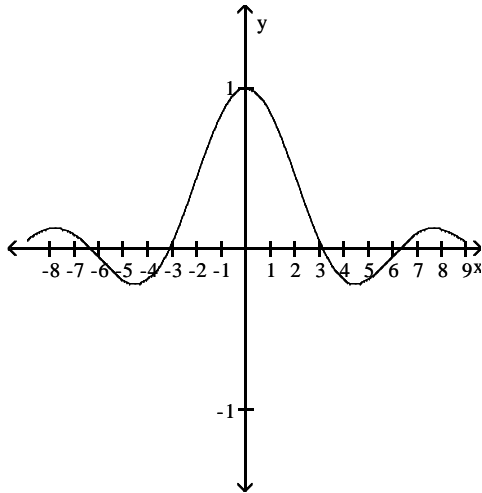

- A) -1 B) 1 C) does not exist D) 0

Find the limit.

37) $\lim_{x \rightarrow 7} (4x + 6)$

37) _____

- A) 10 B) 34 C) -22 D) 6

38) $\lim_{x \rightarrow 2} (x^2 + 8x - 2)$

38) _____

- A) does not exist B) 0 C) 18 D) -18

39) $\lim_{x \rightarrow 0} (x^2 - 5)$

39) _____

- A) 0 B) 5 C) does not exist D) -5

40) $\lim_{x \rightarrow 0} (\sqrt{x} - 2)$ 40) _____
 A) 0 B) does not exist C) 2 D) -2

41) $\lim_{x \rightarrow 2} (x^3 + 5x^2 - 7x + 1)$ 41) _____
 A) 15 B) 0 C) does not exist D) 29

42) $\lim_{x \rightarrow -2} (2x^5 - 2x^4 - 4x^3 + x^2 + 5)$ 42) _____
 A) -55 B) 9 C) 41 D) -119

43) $\lim_{x \rightarrow 7} \sqrt{x^2 + 2x + 1}$ 43) _____
 A) 8 B) ± 8 C) 64 D) does not exist

44) $\lim_{x \rightarrow -1} \frac{x}{3x + 2}$ 44) _____
 A) $-\frac{1}{5}$ B) 0 C) does not exist D) 1

Find the limit if it exists.

45) $\lim_{x \rightarrow 15} \sqrt{3}$ 45) _____
 A) $\sqrt{15}$ B) $\sqrt{3}$ C) 3 D) 15

46) $\lim_{x \rightarrow -1} (10x - 2)$ 46) _____
 A) -12 B) 12 C) 8 D) -8

47) $\lim_{x \rightarrow 12} (5 - 10x)$ 47) _____
 A) 115 B) 125 C) -115 D) -125

48) $\lim_{x \rightarrow -2} (10x^2 - 2x - 10)$ 48) _____
 A) 26 B) 54 C) 34 D) 46

49) $\lim_{x \rightarrow -10} 8x(x + 8)(x - 4)$ 49) _____
 A) -2240 B) -20,160 C) -960 D) 2240

50) $\lim_{x \rightarrow \frac{1}{8}} 8x \left(x - \frac{1}{5} \right)$ 50) _____
 A) $\frac{13}{40}$ B) $-\frac{3}{5}$ C) $-\frac{3}{40}$ D) $-\frac{3}{320}$

- 51) $\lim_{x \rightarrow 25} x^{1/2}$ 51) _____
 A) 25 B) $\frac{25}{2}$ C) 5 D) $\frac{1}{2}$
- 52) $\lim_{x \rightarrow -2} (x + 3)^2(x - 3)^3$ 52) _____
 A) 25 B) -125 C) 1 D) -3125
- 53) $\lim_{x \rightarrow -8} \sqrt{7x + 73}$ 53) _____
 A) -17 B) $\sqrt{17}$ C) 17 D) $-\sqrt{17}$
- 54) $\lim_{x \rightarrow -2} (x - 123)^{4/3}$ 54) _____
 A) -625 B) -125 C) -3125 D) 625

Find the limit, if it exists.

- 55) $\lim_{x \rightarrow 12} \frac{1}{x - 12}$ 55) _____
 A) Does not exist B) 12 C) 0 D) 24
- 56) $\lim_{x \rightarrow 0} \frac{x^3 - 6x + 8}{x - 2}$ 56) _____
 A) 4 B) 0 C) Does not exist D) -4
- 57) $\lim_{x \rightarrow 1} \frac{2x - 7}{4x + 5}$ 57) _____
 A) $-\frac{1}{2}$ B) $-\frac{5}{9}$ C) $-\frac{7}{5}$ D) Does not exist
- 58) $\lim_{x \rightarrow 1} \frac{3x^2 + 7x - 2}{3x^2 - 4x - 2}$ 58) _____
 A) $-\frac{8}{3}$ B) 0 C) Does not exist D) $-\frac{7}{4}$
- 59) $\lim_{x \rightarrow 6} \frac{x + 6}{(x - 6)^2}$ 59) _____
 A) 0 B) -6 C) 6 D) Does not exist
- 60) $\lim_{x \rightarrow 5} \frac{x^2 - 2x - 15}{x + 3}$ 60) _____
 A) -8 B) 5 C) 0 D) Does not exist

- 61) $\lim_{h \rightarrow 0} \frac{2}{\sqrt{3h+4} + 2}$ 61) _____
 A) 1/2 B) 2 C) Does not exist D) 1
- 62) $\lim_{h \rightarrow 0} \frac{17x + h}{x^3(x - h)}$ 62) _____
 A) Does not exist B) $\frac{17}{x^4}$ C) $\frac{17}{x^3}$ D) 17x
- 63) $\lim_{x \rightarrow 0} \frac{\sqrt{1+x} - 1}{x}$ 63) _____
 A) Does not exist B) 1/4 C) 1/2 D) 0
- 64) $\lim_{h \rightarrow 0} \frac{(1+h)^{1/3} - 1}{h}$ 64) _____
 A) 0 B) Does not exist C) 1/3 D) 3
- 65) $\lim_{x \rightarrow 0} \frac{x^3 + 12x^2 - 5x}{5x}$ 65) _____
 A) 5 B) 0 C) Does not exist D) -1
- 66) $\lim_{x \rightarrow 1} \frac{x^4 - 1}{x - 1}$ 66) _____
 A) 2 B) 0 C) Does not exist D) 4
- 67) $\lim_{x \rightarrow 6} \frac{x^2 - 36}{x - 6}$ 67) _____
 A) 6 B) 12 C) Does not exist D) 1
- 68) $\lim_{x \rightarrow -3} \frac{x^2 + 6x + 9}{x + 3}$ 68) _____
 A) Does not exist B) 0 C) 6 D) 36
- 69) $\lim_{x \rightarrow 2} \frac{x^2 + 3x - 10}{x - 2}$ 69) _____
 A) 7 B) Does not exist C) 0 D) 3
- 70) $\lim_{x \rightarrow 4} \frac{x^2 + 4x - 32}{x^2 - 16}$ 70) _____
 A) $\frac{3}{2}$ B) $-\frac{1}{2}$ C) 0 D) Does not exist

71) $\lim_{x \rightarrow 5} \frac{x^2 - 25}{x^2 - 6x + 5}$ 71) _____
 A) Does not exist B) $\frac{5}{2}$ C) $\frac{5}{4}$ D) 0

72) $\lim_{x \rightarrow -1} \frac{x^2 - 5x - 6}{x^2 - 3x - 4}$ 72) _____
 A) Does not exist B) $-\frac{7}{5}$ C) -1 D) $\frac{7}{5}$

73) $\lim_{h \rightarrow 0} \frac{(x+h)^3 - x^3}{h}$ 73) _____
 A) 0 B) $3x^2$ C) $3x^2 + 3xh + h^2$ D) Does not exist

74) $\lim_{x \rightarrow 10} \frac{|10 - x|}{10 - x}$ 74) _____
 A) 1 B) 0 C) -1 D) Does not exist

Find the limit.

75) $\lim_{x \rightarrow 0} (4 \sin x - 1)$ 75) _____
 A) -1 B) 4 - 1 C) 0 D) 4

76) $\lim_{x \rightarrow -\pi} \sqrt{x+1} \cos(x + \pi)$ 76) _____
 A) $-\sqrt{1 - \pi}$ B) 1 C) $\sqrt{1 - \pi}$ D) 0

77) $\lim_{x \rightarrow 0} \sqrt{15 + \cos^2 x}$ 77) _____
 A) 4 B) 16 C) $\sqrt{15}$ D) 15

Provide an appropriate response.

78) Suppose $\lim_{x \rightarrow 0} f(x) = 1$ and $\lim_{x \rightarrow 0} g(x) = -3$. Name the limit rules that are used to accomplish steps 78) _____

(a), (b), and (c) of the following calculation.

$$\begin{aligned} \lim_{x \rightarrow 0} \frac{-3f(x) - 4g(x)}{(f(x) + 3)^{1/2}} & \stackrel{(a)}{=} \frac{\lim_{x \rightarrow 0} (-3f(x) - 4g(x))}{\lim_{x \rightarrow 0} (f(x) + 3)^{1/2}} \\ & \stackrel{(b)}{=} \frac{\lim_{x \rightarrow 0} -3f(x) - \lim_{x \rightarrow 0} 4g(x)}{(\lim_{x \rightarrow 0} (f(x) + 3))^{1/2}} \stackrel{(c)}{=} \frac{-3 \lim_{x \rightarrow 0} f(x) - 4 \lim_{x \rightarrow 0} g(x)}{(\lim_{x \rightarrow 0} f(x) + \lim_{x \rightarrow 0} 3)^{1/2}} \\ & = \frac{-3 + 12}{(1 + 3)^{1/2}} = \frac{9}{2} \end{aligned}$$

- A) (a) Difference Rule
 (b) Power Rule
 (c) Sum Rule
 B) (a) Quotient Rule
 (b) Difference Rule, Power Rule
 (c) Constant Multiple Rule and Sum Rule
 C) (a) Quotient Rule
 (b) Difference Rule, Sum Rule
 (c) Constant Multiple Rule and Power Rule
 D) (a) Quotient Rule
 (b) Difference Rule
 (c) Constant Multiple Rule

79) Let $\lim_{x \rightarrow 6} f(x) = -9$ and $\lim_{x \rightarrow 6} g(x) = 6$. Find $\lim_{x \rightarrow 6} [f(x) - g(x)]$. 79) _____

- A) 6 B) -3 C) -9 D) -15

80) Let $\lim_{x \rightarrow -5} f(x) = 9$ and $\lim_{x \rightarrow -5} g(x) = 2$. Find $\lim_{x \rightarrow -5} [f(x) \cdot g(x)]$. 80) _____

- A) 18 B) 11 C) 2 D) -5

81) Let $\lim_{x \rightarrow 3} f(x) = -1$ and $\lim_{x \rightarrow 3} g(x) = -5$. Find $\lim_{x \rightarrow 3} \frac{f(x)}{g(x)}$. 81) _____

- A) $\frac{1}{5}$ B) 5 C) 3 D) 4

82) Let $\lim_{x \rightarrow -8} f(x) = 32$. Find $\lim_{x \rightarrow -8} \log_2 f(x)$. 82) _____

- A) $\frac{5}{2}$ B) 25 C) 5 D) -8

83) Let $\lim_{x \rightarrow 1} f(x) = 49$. Find $\lim_{x \rightarrow 1} \sqrt{f(x)}$. 83) _____

- A) 1 B) 2.6458 C) 49 D) 7

- 84) Let $\lim_{x \rightarrow 2} f(x) = -5$ and $\lim_{x \rightarrow 2} g(x) = -7$. Find $\lim_{x \rightarrow 2} [f(x) + g(x)]^2$. 84) _____
 A) -12 B) 74 C) 144 D) 2
- 85) Let $\lim_{x \rightarrow 4} f(x) = 2$. Find $\lim_{x \rightarrow 4} (-4)^{f(x)}$. 85) _____
 A) 16 B) -4 C) 256 D) 2
- 86) Let $\lim_{x \rightarrow 7} f(x) = 32$. Find $\lim_{x \rightarrow 7} \sqrt[5]{f(x)}$. 86) _____
 A) 7 B) 32 C) 2 D) 5
- 87) Let $\lim_{x \rightarrow 9} f(x) = 6$ and $\lim_{x \rightarrow 9} g(x) = -9$. Find $\lim_{x \rightarrow 9} \left[\frac{-4f(x) - 3g(x)}{2 + g(x)} \right]$. 87) _____
 A) -15 B) 9 C) $-\frac{3}{7}$ D) $\frac{51}{7}$

Because of their connection with secant lines, tangents, and instantaneous rates, limits of the form

$\lim_{h \rightarrow 0} \frac{f(x+h) - f(x)}{h}$ occur frequently in calculus. Evaluate this limit for the given value of x and function f .

- 88) $f(x) = 4x^2$, $x = 8$ 88) _____
 A) 256 B) 32 C) 64 D) Does not exist
- 89) $f(x) = 4x^2 - 2$, $x = -1$ 89) _____
 A) -8 B) Does not exist C) 4 D) -10
- 90) $f(x) = 2x + 5$, $x = 4$ 90) _____
 A) 13 B) 2 C) 8 D) Does not exist
- 91) $f(x) = \frac{x}{3} + 1$, $x = 6$ 91) _____
 A) Does not exist B) 3 C) 2 D) $\frac{1}{3}$
- 92) $f(x) = \frac{2}{x}$, $x = 8$ 92) _____
 A) -16 B) Does not exist C) $\frac{1}{4}$ D) $-\frac{1}{32}$
- 93) $f(x) = 5\sqrt{x}$, $x = 4$ 93) _____
 A) 5 B) Does not exist C) $\frac{5}{4}$ D) 10

94) $f(x) = \sqrt{x}$, $x = 3$ 94) _____
 A) $\frac{3}{2}$ B) Does not exist C) $\frac{\sqrt{3}}{6}$ D) $\frac{\sqrt{3}}{3}$

95) $f(x) = 3\sqrt{x} + 5$, $x = 16$ 95) _____
 A) $\frac{3}{8}$ B) 24 C) 6 D) Does not exist

Provide an appropriate response.

96) It can be shown that the inequalities $-x \leq x \cos\left(\frac{1}{x}\right) \leq x$ hold for all values of $x \geq 0$. 96) _____

Find $\lim_{x \rightarrow 0} x \cos\left(\frac{1}{x}\right)$ if it exists.

- A) 0.0007 B) 0 C) does not exist D) 1

97) The inequality $1 - \frac{x^2}{2} < \frac{\sin x}{x} < 1$ holds when x is measured in radians and $|x| < 1$. 97) _____

Find $\lim_{x \rightarrow 0} \frac{\sin x}{x}$ if it exists.

- A) 0.0007 B) does not exist C) 1 D) 0

98) If $x^3 \leq f(x) \leq x$ for x in $[-1, 1]$, find $\lim_{x \rightarrow 0} f(x)$ if it exists. 98) _____

- A) 1 B) does not exist C) -1 D) 0

Use the table of values of f to estimate the limit.

99) Let $f(x) = x^2 + 8x - 2$, find $\lim_{x \rightarrow 2} f(x)$. 99) _____

x	1.9	1.99	1.999	2.001	2.01	2.1
$f(x)$						

A)

x	1.9	1.99	1.999	2.001	2.01	2.1
$f(x)$	16.692	17.592	17.689	17.710	17.808	18.789

; limit = 17.70

B)

x	1.9	1.99	1.999	2.001	2.01	2.1
$f(x)$	5.043	5.364	5.396	5.404	5.436	5.763

; limit = ∞

C)

x	1.9	1.99	1.999	2.001	2.01	2.1
$f(x)$	5.043	5.364	5.396	5.404	5.436	5.763

; limit = 5.40

D)

x	1.9	1.99	1.999	2.001	2.01	2.1
$f(x)$	16.810	17.880	17.988	18.012	18.120	19.210

; limit = 18.0

100) Let $f(x) = \frac{x-4}{\sqrt{x}-2}$, find $\lim_{x \rightarrow 4} f(x)$.

100) _____

x	3.9	3.99	3.999	4.001	4.01	4.1
f(x)						

A)

x	3.9	3.99	3.999	4.001	4.01	4.1	
f(x)	5.07736	5.09775	5.09978	5.10022	5.10225	5.12236	; limit = 5.10

B)

x	3.9	3.99	3.999	4.001	4.01	4.1	
f(x)	1.19245	1.19925	1.19993	1.20007	1.20075	1.20745	; limit = 1.20

C)

x	3.9	3.99	3.999	4.001	4.01	4.1	
f(x)	1.19245	1.19925	1.19993	1.20007	1.20075	1.20745	; limit = ∞

D)

x	3.9	3.99	3.999	4.001	4.01	4.1	
f(x)	3.97484	3.99750	3.99975	4.00025	4.00250	4.02485	; limit = 4.0

101) Let $f(x) = x^2 - 5$, find $\lim_{x \rightarrow 0} f(x)$.

101) _____

x	-0.1	-0.01	-0.001	0.001	0.01	0.1
f(x)						

A)

x	-0.1	-0.01	-0.001	0.001	0.01	0.1	
f(x)	-2.9910	-2.9999	-3.0000	-3.0000	-2.9999	-2.9910	; limit = -3.0

B)

x	-0.1	-0.01	-0.001	0.001	0.01	0.1	
f(x)	-1.4970	-1.4999	-1.5000	-1.5000	-1.4999	-1.4970	; limit = ∞

C)

x	-0.1	-0.01	-0.001	0.001	0.01	0.1	
f(x)	-4.9900	-4.9999	-5.0000	-5.0000	-4.9999	-4.9900	; limit = -5.0

D)

x	-0.1	-0.01	-0.001	0.001	0.01	0.1	
f(x)	-1.4970	-1.4999	-1.5000	-1.5000	-1.4999	-1.4970	; limit = -15.0

102) Let $f(x) = \frac{x-1}{x^2+3x-4}$, find $\lim_{x \rightarrow 1} f(x)$.

102) _____

x	0.9	0.99	0.999	1.001	1.01	1.1
f(x)						

A)

x	0.9	0.99	0.999	1.001	1.01	1.1
f(x)	0.1041	0.1004	0.1000	0.1000	0.0996	0.0961

; limit = 0.1

B)

x	0.9	0.99	0.999	1.001	1.01	1.1
f(x)	0.3041	0.3004	0.3000	0.3000	0.2996	0.2961

; limit = 0.3

C)

x	0.9	0.99	0.999	1.001	1.01	1.1
f(x)	0.2041	0.2004	0.2000	0.2000	0.1996	0.1961

; limit = 0.2

D)

x	0.9	0.99	0.999	1.001	1.01	1.1
f(x)	-0.2041	-0.2004	-0.2000	-0.2000	-0.1996	-0.1961

; limit = -0.2

103) Let $f(x) = \frac{x^2 - 4x + 3}{x^2 - 7x + 12}$, find $\lim_{x \rightarrow 3} f(x)$.

103) _____

x	2.9	2.99	2.999	3.001	3.01	3.1
f(x)						

A)

x	2.9	2.99	2.999	3.001	3.01	3.1
f(x)	-1.8273	-2.0703	-2.0970	-2.1030	-2.1303	-2.4333

; limit = -2.1

B)

x	2.9	2.99	2.999	3.001	3.01	3.1
f(x)	-1.7273	-1.9703	-1.9970	-2.0030	-2.0303	-2.3333

; limit = -2

C)

x	2.9	2.99	2.999	3.001	3.01	3.1
f(x)	0.5775	0.5720	0.5715	0.5714	0.5708	0.5652

; limit = 0.5714

D)

x	2.9	2.99	2.999	3.001	3.01	3.1
f(x)	-1.6273	-1.8703	-1.8970	-1.9030	-1.9303	-2.2333

; limit = -1.9

104) Let $f(x) = \frac{\sin(4x)}{x}$, find $\lim_{x \rightarrow 0} f(x)$.

104) _____

x	-0.1	-0.01	-0.001	0.001	0.01	0.1
f(x)		3.99893342			3.99893342	

A) limit = 3.5

B) limit does not exist

C) limit = 0

D) limit = 4

105) Let $f(\theta) = \frac{\cos(8\theta)}{\theta}$, find $\lim_{\theta \rightarrow 0} f(\theta)$.

105) _____

x	-0.1	-0.01	-0.001	0.001	0.01	0.1
f(θ)	-6.9670671					6.9670671

A) limit = 8

B) limit = 6.9670671

C) limit does not exist

D) limit = 0

Find the limit.

106) If $\lim_{x \rightarrow 3} \frac{f(x) - 1}{x - 1} = 2$, find $\lim_{x \rightarrow 3} f(x)$.

106) _____

A) 6

B) 3

C) 5

D) Does not exist

107) If $\lim_{x \rightarrow 2} \frac{f(x)}{x} = 3$, find $\lim_{x \rightarrow 2} f(x)$.

107) _____

A) 2

B) 6

C) 3

D) Does not exist

108) If $\lim_{x \rightarrow 2} \frac{f(x)}{x^2} = 4$, find $\lim_{x \rightarrow 2} \frac{f(x)}{x}$.

108) _____

A) 8

B) 2

C) 16

D) 4

109) If $\lim_{x \rightarrow 0} \frac{f(x)}{x} = 1$, find $\lim_{x \rightarrow 0} f(x)$.

109) _____

A) 2

B) 0

C) 1

D) Does not exist

110) If $\lim_{x \rightarrow 0} \frac{f(x)}{x^2} = 1$, find $\lim_{x \rightarrow 0} \frac{f(x)}{x}$.

110) _____

A) 0

B) 2

C) 1

D) Does not exist

111) If $\lim_{x \rightarrow 1} \frac{f(x) - 3}{x - 1} = 2$, find $\lim_{x \rightarrow 1} f(x)$.

111) _____

A) 1

B) 2

C) 3

D) Does not exist

Use a CAS to plot the function near the point x_0 being approached. From your plot guess the value of the limit.

112) $\lim_{x \rightarrow 64} \frac{\sqrt{x} - 8}{x - 64}$

112) _____

A) 8

B) $\frac{1}{8}$

C) $\frac{1}{16}$

D) 0

113) $\lim_{x \rightarrow 1} \frac{1 - \sqrt{x}}{1 - x}$

113) _____

A) 1

B) 2

C) $\frac{1}{2}$

D) 0

- 114) $\lim_{x \rightarrow 0} \frac{\sqrt{9+x} - \sqrt{9-x}}{x}$ 114) _____
 A) 3 B) 0 C) $\frac{1}{6}$ D) $\frac{1}{3}$
- 115) $\lim_{x \rightarrow 0} \frac{\sqrt{81-x} - 9}{x}$ 115) _____
 A) 9 B) $-\frac{1}{18}$ C) 18 D) $\frac{1}{18}$
- 116) $\lim_{x \rightarrow 0} \frac{\sqrt{81+2x} - 9}{x}$ 116) _____
 A) 81 B) $\frac{1}{9}$ C) $\frac{1}{18}$ D) $\frac{2}{9}$
- 117) $\lim_{x \rightarrow 0} \frac{\sqrt{3+3x} - \sqrt{3}}{x}$ 117) _____
 A) 0 B) $\frac{\sqrt{3}}{2}$ C) $\frac{1}{2}$ D) $\sqrt{3}$
- 118) $\lim_{x \rightarrow 0} \frac{3 - \sqrt{9-x^2}}{x}$ 118) _____
 A) $\frac{1}{3}$ B) 6 C) $\frac{1}{6}$ D) 0
- 119) $\lim_{x \rightarrow 3} \frac{x^2 - 9}{\sqrt{x^2 + 7} - 4}$ 119) _____
 A) 3 B) 4 C) $\frac{1}{4}$ D) 8
- 120) $\lim_{x \rightarrow -1} \frac{x^2 - 1}{\sqrt{x^2 + 3} - 2}$ 120) _____
 A) 1 B) 4 C) $\frac{1}{4}$ D) 2

SHORT ANSWER. Write the word or phrase that best completes each statement or answers the question.

Provide an appropriate response.

- 121) It can be shown that the inequalities $1 - \frac{x^2}{6} < \frac{x \sin(x)}{2 - 2 \cos(x)} < 1$ hold for all values of x close to zero. What, if anything, does this tell you about $\frac{x \sin(x)}{2 - 2 \cos(x)}$? Explain. 121) _____

MULTIPLE CHOICE. Choose the one alternative that best completes the statement or answers the question.

122) Write the formal notation for the principle "the limit of a quotient is the quotient of the limits" and include a statement of any restrictions on the principle. 122) _____

A) If $\lim_{x \rightarrow a} g(x) = M$ and $\lim_{x \rightarrow a} f(x) = L$, then $\lim_{x \rightarrow a} \frac{g(x)}{f(x)} = \frac{\lim_{x \rightarrow a} g(x)}{\lim_{x \rightarrow a} f(x)} = \frac{M}{L}$, provided that

$f(a) \neq 0$.

B) If $\lim_{x \rightarrow a} g(x) = M$ and $\lim_{x \rightarrow a} f(x) = L$, then $\lim_{x \rightarrow a} \frac{g(x)}{f(x)} = \frac{\lim_{x \rightarrow a} g(x)}{\lim_{x \rightarrow a} f(x)} = \frac{M}{L}$, provided that

$L \neq 0$.

C) $\lim_{x \rightarrow a} \frac{g(x)}{f(x)} = \frac{g(a)}{f(a)}$.

D) $\lim_{x \rightarrow a} \frac{g(x)}{f(x)} = \frac{g(a)}{f(a)}$, provided that $f(a) \neq 0$.

123) What conditions, when present, are sufficient to conclude that a function $f(x)$ has a limit as x approaches some value of a ? 123) _____

- A) Either the limit of $f(x)$ as $x \rightarrow a$ from the left exists or the limit of $f(x)$ as $x \rightarrow a$ from the right exists
- B) The limit of $f(x)$ as $x \rightarrow a$ from the left exists, the limit of $f(x)$ as $x \rightarrow a$ from the right exists, and these two limits are the same.
- C) The limit of $f(x)$ as $x \rightarrow a$ from the left exists, the limit of $f(x)$ as $x \rightarrow a$ from the right exists, and at least one of these limits is the same as $f(a)$.
- D) $f(a)$ exists, the limit of $f(x)$ as $x \rightarrow a$ from the left exists, and the limit of $f(x)$ as $x \rightarrow a$ from the right exists.

124) Provide a short sentence that summarizes the general limit principle given by the formal notation $\lim_{x \rightarrow a} [f(x) \pm g(x)] = \lim_{x \rightarrow a} f(x) \pm \lim_{x \rightarrow a} g(x) = L \pm M$, given that $\lim_{x \rightarrow a} f(x) = L$ and $\lim_{x \rightarrow a} g(x) = M$. 124) _____

- A) The sum or the difference of two functions is continuous.
- B) The sum or the difference of two functions is the sum of two limits.
- C) The limit of a sum or a difference is the sum or the difference of the limits.
- D) The limit of a sum or a difference is the sum or the difference of the functions.

125) The statement "the limit of a constant times a function is the constant times the limit" follows from a combination of two fundamental limit principles. What are they? 125) _____

- A) The limit of a product is the product of the limits, and the limit of a quotient is the quotient of the limits.
- B) The limit of a constant is the constant, and the limit of a product is the product of the limits.
- C) The limit of a function is a constant times a limit, and the limit of a constant is the constant.
- D) The limit of a product is the product of the limits, and a constant is continuous.

Given the interval (a, b) on the x -axis with the point c inside, find the greatest value for $\delta > 0$ such that for all x , $0 < |x - c| < \delta \Rightarrow a < x < b$.

126) $a = -10, b = 0, c = -8$ 126) _____

- A) $\delta = 4$
- B) $\delta = 1$
- C) $\delta = 2$
- D) $\delta = 8$

127) $a = \frac{2}{9}, b = \frac{9}{9}, c = \frac{4}{9}$

A) $\delta = \frac{5}{9}$

B) $\delta = \frac{1}{9}$

C) $\delta = \frac{2}{9}$

D) $\delta = 2$

127) _____

128) $a = 1.373, b = 2.751, c = 1.859$

A) $\delta = 0.892$

B) $\delta = 1$

C) $\delta = 1.378$

D) $\delta = 0.486$

128) _____

Use the graph to find a $\delta > 0$ such that for all $x, 0 < |x - c| < \delta \Rightarrow |f(x) - L| < \epsilon$.

129)

129) _____

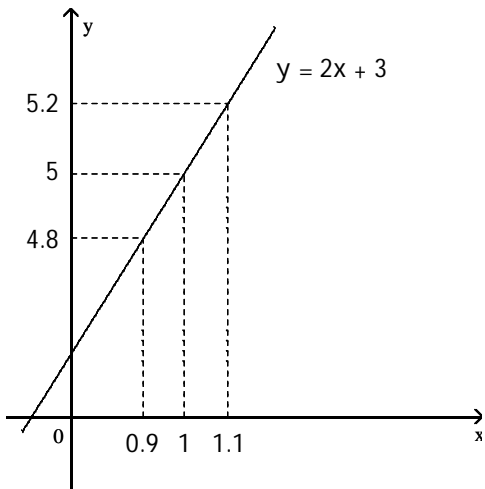

$f(x) = 2x + 3$
 $c = 1$
 $L = 5$
 $\epsilon = 0.2$

NOT TO SCALE

A) $\delta = 0.1$

B) $\delta = 0.4$

C) $\delta = 4$

D) $\delta = 0.2$

130)

130) _____

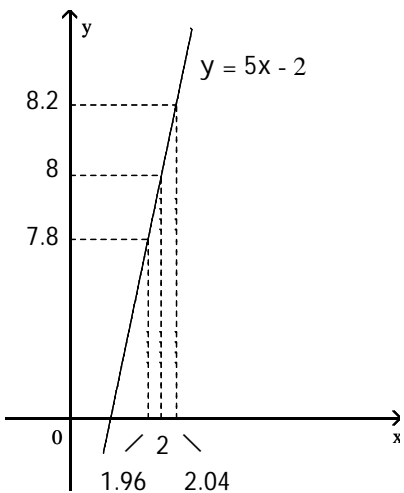

$f(x) = 5x - 2$
 $c = 2$
 $L = 8$
 $\epsilon = 0.2$

NOT TO SCALE

A) $\delta = 6$

B) $\delta = 0.08$

C) $\delta = 0.4$

D) $\delta = 0.04$

131)

131) _____

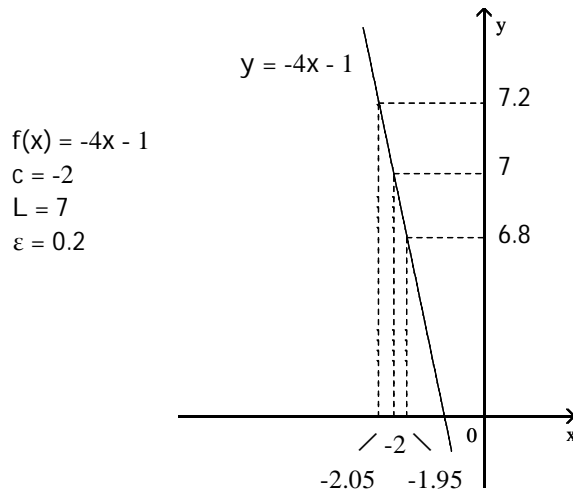

NOT TO SCALE

A) $\delta = -0.05$

B) $\delta = 0.05$

C) $\delta = 0.5$

D) $\delta = 11$

132)

132) _____

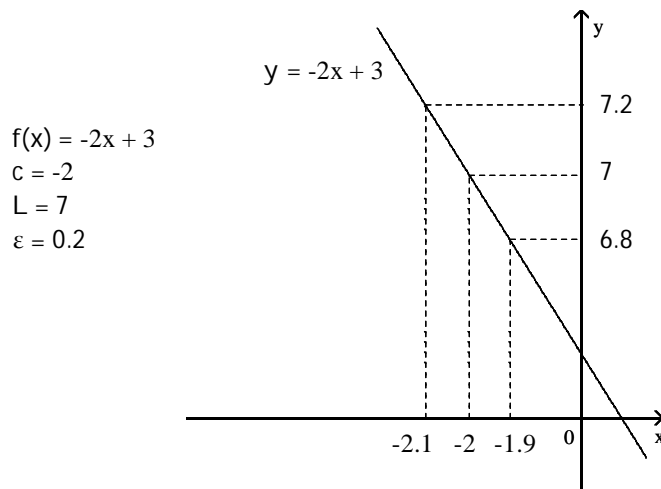

NOT TO SCALE

A) $\delta = 0.2$

B) $\delta = -0.1$

C) $\delta = 9$

D) $\delta = 0.1$

133)

133) _____

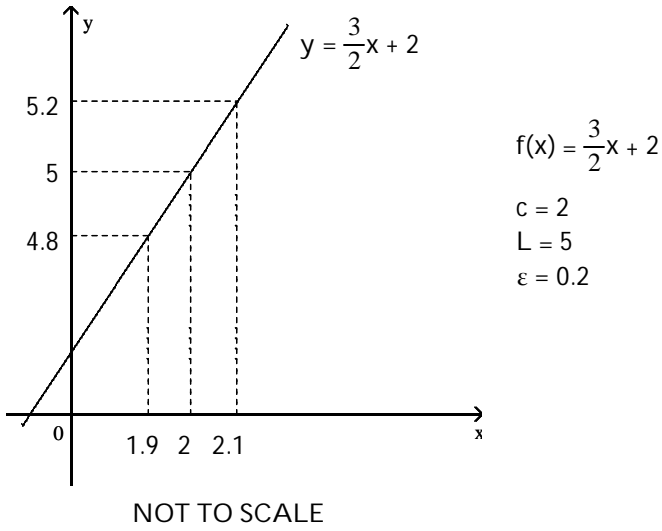

A) $\delta = 0.1$

B) $\delta = 3$

C) $\delta = -0.2$

D) $\delta = 0.2$

134)

134) _____

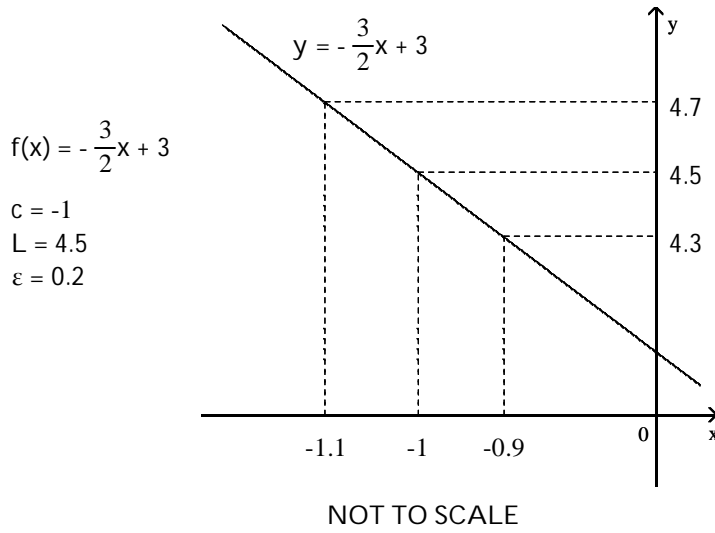

A) $\delta = 0.1$

B) $\delta = -0.2$

C) $\delta = 0.2$

D) $\delta = 5.5$

135)

135) _____

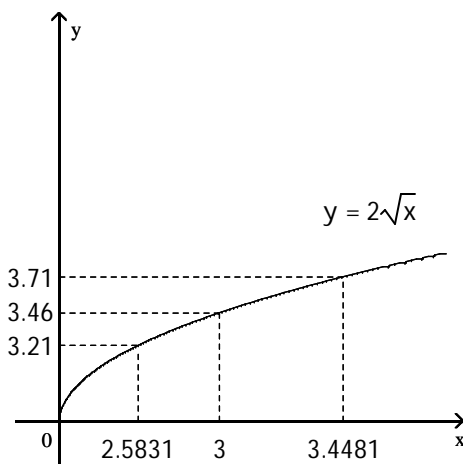

$$f(x) = 2\sqrt{x}$$

$$c = 3$$

$$L = 2\sqrt{3}$$

$$\varepsilon = \frac{1}{4}$$

NOT TO SCALE

A) $\delta = 0.46$

B) $\delta = 0.4169$

C) $\delta = 0.4481$

D) $\delta = 0.865$

136)

136) _____

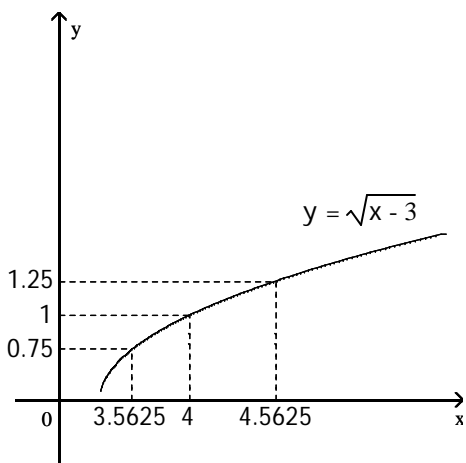

$$f(x) = \sqrt{x-3}$$

$$c = 4$$

$$L = 1$$

$$\varepsilon = \frac{1}{4}$$

NOT TO SCALE

A) $\delta = 0.5625$

B) $\delta = 0.4375$

C) $\delta = 1$

D) $\delta = 3$

137)

137) _____

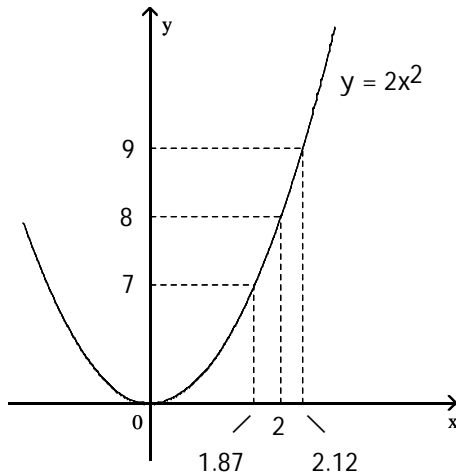

$$f(x) = 2x^2$$

$$c = 2$$

$$L = 8$$

$$\varepsilon = 1$$

NOT TO SCALE

A) $\delta = 0.13$

B) $\delta = 0.12$

C) $\delta = 0.25$

D) $\delta = 6$

138)

138) _____

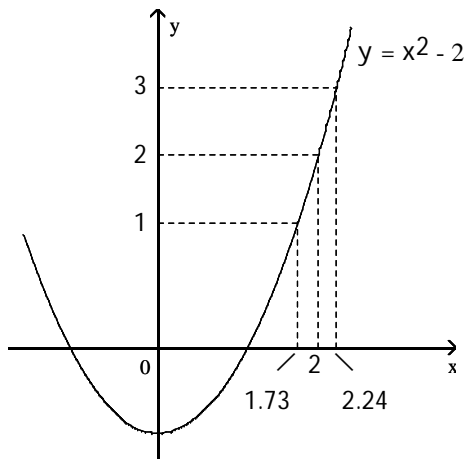

$$f(x) = x^2 - 2$$

$$c = 2$$

$$L = 2$$

$$\varepsilon = 1$$

NOT TO SCALE

A) $\delta = 0.27$

B) $\delta = 0.24$

C) $\delta = 0$

D) $\delta = 0.51$

A function $f(x)$, a point c , the limit of $f(x)$ as x approaches c , and a positive number ε is given. Find a number $\delta > 0$ such that for all x , $0 < |x - c| < \delta \Rightarrow |f(x) - L| < \varepsilon$.

139) $f(x) = 5x + 9$, $L = 29$, $c = 4$, and $\varepsilon = 0.01$

A) $\delta = 0.01$

B) $\delta = 0.002$

C) $\delta = 0.004$

D) $\delta = 0.0025$

139) _____

140) $f(x) = 10x - 1$, $L = 29$, $c = 3$, and $\varepsilon = 0.01$

A) $\delta = 0.002$

B) $\delta = 0.001$

C) $\delta = 0.003333$

D) $\delta = 0.0005$

140) _____

141) $f(x) = -7x + 10$, $L = -18$, $c = 4$, and $\varepsilon = 0.01$

A) $\delta = 0.001429$

B) $\delta = 0.005714$

C) $\delta = -0.0025$

D) $\delta = 0.002857$

141) _____

- 142) $f(x) = -9x - 1$, $L = -19$, $c = 2$, and $\varepsilon = 0.01$ 142) _____
 A) $\delta = 0.001111$ B) $\delta = 0.000556$ C) $\delta = 0.002222$ D) $\delta = -0.005$
- 143) $f(x) = \sqrt{x+2}$, $L = 2$, $c = 2$, and $\varepsilon = 1$ 143) _____
 A) $\delta = 1$ B) $\delta = 9$ C) $\delta = 5$ D) $\delta = 3$
- 144) $f(x) = \sqrt{7-x}$, $L = 2$, $c = 3$, and $\varepsilon = 1$ 144) _____
 A) $\delta = 4$ B) $\delta = 3$ C) $\delta = 6$ D) $\delta = -5$
- 145) $f(x) = 7x^2$, $L = 567$, $c = 9$, and $\varepsilon = 0.4$ 145) _____
 A) $\delta = 0.00318$ B) $\delta = 9.00317$ C) $\delta = 0.00317$ D) $\delta = 8.99682$
- 146) $f(x) = \frac{1}{x}$, $L = \frac{1}{9}$, $c = 9$, and $\varepsilon = 0.1$ 146) _____
 A) $\delta = 81$ B) $\delta = 0.4737$ C) $\delta = 4.2632$ D) $\delta = 810$
- 147) $f(x) = mx$, $m > 0$, $L = 6m$, $c = 6$, and $\varepsilon = 0.05$ 147) _____
 A) $\delta = \frac{0.05}{m}$ B) $\delta = 6 - m$ C) $\delta = 6 + \frac{0.05}{m}$ D) $\delta = 0.05$
- 148) $f(x) = mx + b$, $m > 0$, $L = \frac{m}{8} + b$, $c = \frac{1}{8}$, and $\varepsilon = c > 0$ 148) _____
 A) $\delta = \frac{c}{m}$ B) $\delta = \frac{1}{8} + \frac{c}{m}$ C) $\delta = \frac{c}{8}$ D) $\delta = \frac{8}{m}$

Find the limit L for the given function f , the point c , and the positive number ε . Then find a number $\delta > 0$ such that, for all x , $0 < |x - c| < \delta \Rightarrow |f(x) - L| < \varepsilon$.

- 149) $f(x) = 6x - 2$, $c = -3$, $\varepsilon = 0.12$ 149) _____
 A) $L = 16$; $\delta = 0.03$ B) $L = -16$; $\delta = 0.02$
 C) $L = -20$; $\delta = 0.03$ D) $L = -20$; $\delta = 0.02$
- 150) $f(x) = \frac{x^2 + 2x + -80}{x + 10}$, $c = -10$, $\varepsilon = 0.03$ 150) _____
 A) $L = -18$; $\delta = 0.03$ B) $L = -16$; $\delta = 0.04$
 C) $L = 2$; $\delta = 0.04$ D) $L = 0$; $\delta = 0.03$
- 151) $f(x) = \sqrt{8 - 2x}$, $c = -4$, $\varepsilon = 0.5$ 151) _____
 A) $L = 4$; $\delta = 1.88$ B) $L = j-3$; $\delta = 0.88$
 C) $L = 4$; $\delta = 2.13$ D) $L = 5$; $\delta = 1.88$
- 152) $f(x) = \frac{36}{x}$, $c = 9$, $\varepsilon = 0.2$ 152) _____
 A) $L = 4$; $\delta = 4.74$ B) $L = 4$; $\delta = 0.47$ C) $L = 4$; $\delta = 0.95$ D) $L = 4$; $\delta = 0.43$

SHORT ANSWER. Write the word or phrase that best completes each statement or answers the question.

Prove the limit statement

153) $\lim_{x \rightarrow 1} (2x - 3) = -1$ 153) _____

154) $\lim_{x \rightarrow 3} \frac{x^2 - 9}{x - 3} = 6$ 154) _____

155) $\lim_{x \rightarrow 2} \frac{3x^2 - 5x - 2}{x - 2} = 7$ 155) _____

156) $\lim_{x \rightarrow 7} \frac{1}{x} = \frac{1}{7}$ 156) _____

MULTIPLE CHOICE. Choose the one alternative that best completes the statement or answers the question.

Solve the problem.

- 157) You are asked to make some circular cylinders, each with a cross-sectional area of 6 cm^2 . To do this, you need to know how much deviation from the ideal cylinder diameter of $x_0 = 2.65 \text{ cm}$ you can allow and still have the area come within 0.1 cm^2 of the required 6 cm^2 . To find out, let $A = \pi \left(\frac{x}{2}\right)^2$ and look for the interval in which you must hold x to make $|A - 6| < 0.1$. What interval do you find?
 A) (4.8580, 4.9396) B) (2.7408, 2.7869) C) (0.5642, 0.5642) D) (1.9381, 1.9706) 157) _____

- 158) Ohm's Law for electrical circuits is stated $V = RI$, where V is a constant voltage, R is the resistance in ohms and I is the current in amperes. Your firm has been asked to supply the resistors for a circuit in which V will be 10 volts and I is to be 5 ± 0.1 amperes. In what interval does R have to lie for I to be within 0.1 amps of the target value $I_0 = 5$?
 A) $\left(\frac{100}{51}, \frac{100}{49}\right)$ B) $\left(\frac{10}{49}, \frac{10}{51}\right)$ C) $\left(\frac{100}{49}, \frac{100}{51}\right)$ D) $\left(\frac{51}{100}, \frac{49}{100}\right)$ 158) _____

- 159) The cross-sectional area of a cylinder is given by $A = \pi D^2/4$, where D is the cylinder diameter. Find the tolerance range of D such that $|A - 10| < 0.01$ as long as $D_{\min} < D < D_{\max}$.
 A) $D_{\min} = 3.567, D_{\max} = 3.578$ B) $D_{\min} = 3.558, D_{\max} = 3.578$
 C) $D_{\min} = 3.558, D_{\max} = 3.570$ D) $D_{\min} = 3.567, D_{\max} = 3.570$ 159) _____

- 160) The current in a simple electrical circuit is given by $I = V/R$, where I is the current in amperes, V is the voltage in volts, and R is the resistance in ohms. When $V = 12$ volts, what is a 12Ω resistor's tolerance for the current to be within 1 ± 0.01 amp?
 A) 10% B) 1% C) 0.01% D) 0.1% 160) _____

Provide an appropriate response.

- 161) The definition of the limit, $\lim_{x \rightarrow c} f(x) = L$, means if given any number $\epsilon > 0$, there exists a number $\delta > 0$, such that for all $x, 0 < |x - c| < \delta$ implies _____.
 A) $|f(x) - L| < \epsilon$ B) $|f(x) - L| > \epsilon$ C) $|f(x) - L| > \delta$ D) $|f(x) - L| < \delta$ 161) _____

162) Identify the incorrect statements about limits.

162) _____

I. The number L is the limit of $f(x)$ as x approaches c if $f(x)$ gets closer to L as x approaches x_0 .

II. The number L is the limit of $f(x)$ as x approaches c if, for any $\varepsilon > 0$, there corresponds a $\delta > 0$ such that $|f(x) - L| < \varepsilon$ whenever $0 < |x - c| < \delta$.

III. The number L is the limit of $f(x)$ as x approaches c if, given any $\varepsilon > 0$, there exists a value of x for which $|f(x) - L| < \varepsilon$.

A) II and III

B) I and III

C) I and II

D) I, II, and III

Use the graph to estimate the specified limit.

163) Find $\lim_{x \rightarrow (-1)^-} f(x)$ and $\lim_{x \rightarrow (-1)^+} f(x)$

163) _____

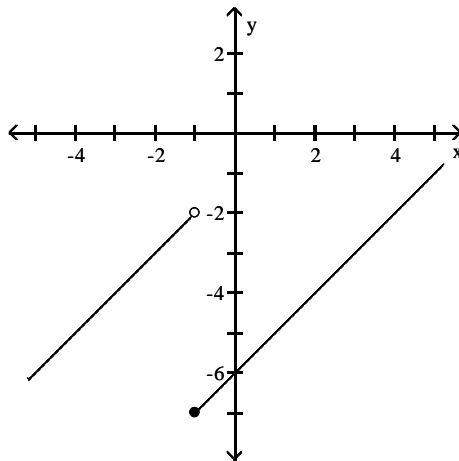

A) -2; -7

B) -5; -2

C) -7; -2

D) -7; -5

164) Find $\lim_{x \rightarrow 0} f(x)$

164) _____

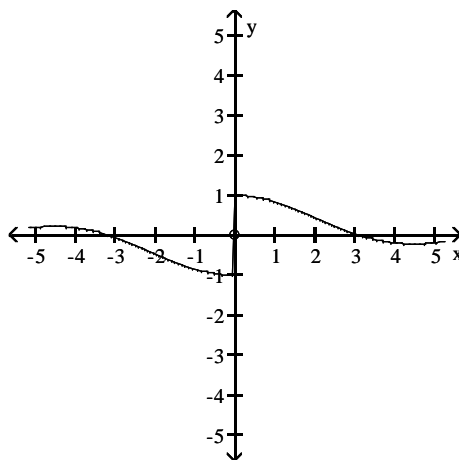

A) 1

B) -1

C) 0

D) does not exist

165) Find $\lim_{x \rightarrow 0} f(x)$

165) _____

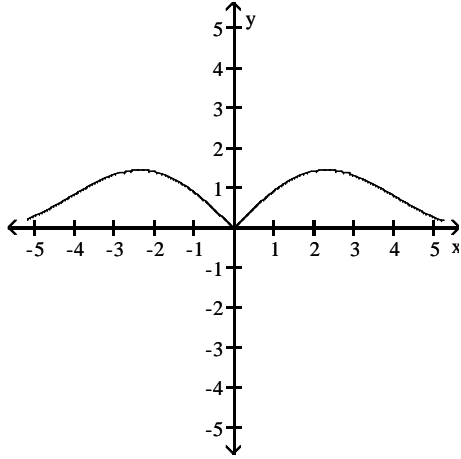

A) 2

B) 0

C) -2

D) does not exist

166) Find $\lim_{x \rightarrow 3^-} f(x)$

166) _____

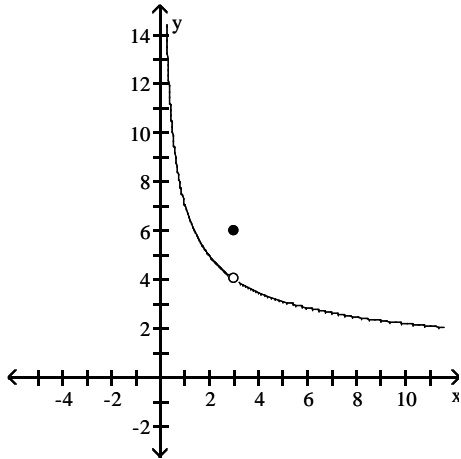

A) $\frac{7}{3}$

B) $-\frac{7\sqrt{3}}{3}$

C) $\frac{7\sqrt{3}}{3}$

D) -3

167) Find $\lim_{x \rightarrow (\pi/2)^-} f(x)$ and $\lim_{x \rightarrow (\pi/2)^+} f(x)$

167) _____

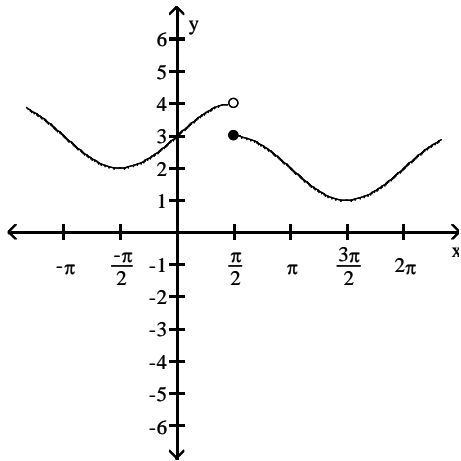

A) 4; 3

B) π ; π

C) 3; 4

D) $\frac{\pi}{2}$; $\frac{\pi}{2}$

168) Find $\lim_{x \rightarrow 0^-} f(x)$ and $\lim_{x \rightarrow 0^+} f(x)$

168) _____

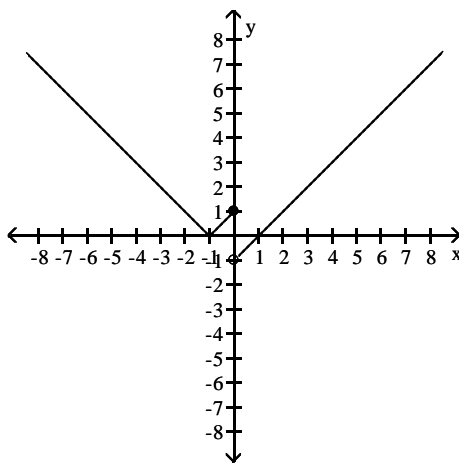

A) 1; 1

B) 1; -1

C) -1; -1

D) -1; 1

169) Find $\lim_{x \rightarrow 2^-} f(x)$ and $\lim_{x \rightarrow 2^+} f(x)$

169) _____

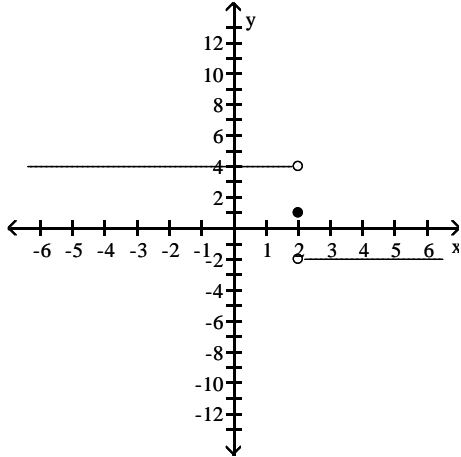

- A) 1; 1
- C) -2; 4

- B) 4; -2
- D) does not exist; does not exist

170) Find $\lim_{x \rightarrow 0} f(x)$

170) _____

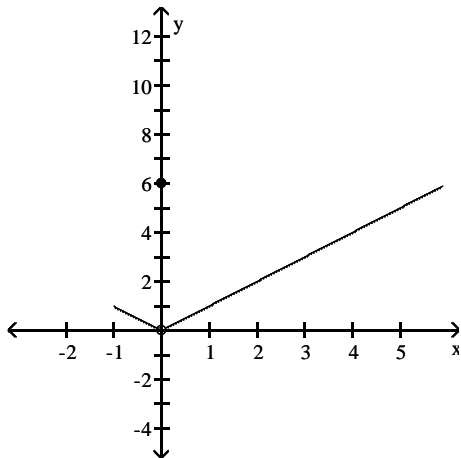

A) 6

B) 0

C) does not exist

D) -1

Determine the limit by sketching an appropriate graph.

171) $\lim_{x \rightarrow 1^-} f(x)$, where $f(x) = \begin{cases} -4x - 6 & \text{for } x < 1 \\ 2x - 5 & \text{for } x \geq 1 \end{cases}$

171) _____

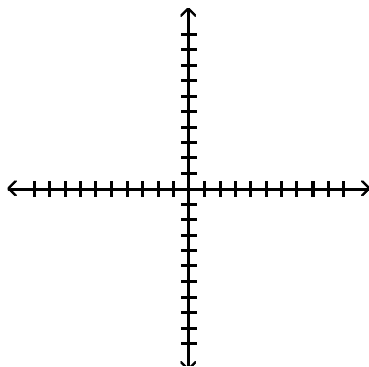

A) -4

B) -5

C) -10

D) -3

172) $\lim_{x \rightarrow 4^+} f(x)$, where $f(x) = \begin{cases} -5x - 4 & \text{for } x < 4 \\ 5x - 3 & \text{for } x \geq 4 \end{cases}$

172) _____

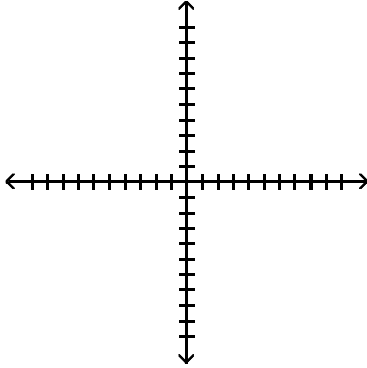

- A) -24 B) -3 C) -2 D) 17

173) $\lim_{x \rightarrow -4^+} f(x)$, where $f(x) = \begin{cases} x^2 + 3 & \text{for } x \neq -4 \\ 0 & \text{for } x = -4 \end{cases}$

173) _____

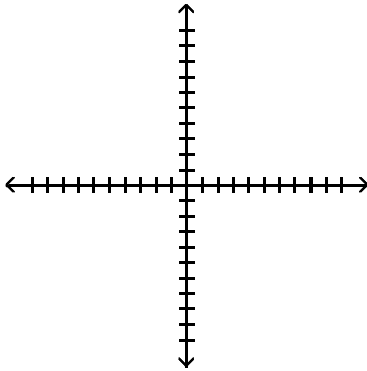

- A) 16 B) 0 C) 13 D) 19

174) $\lim_{x \rightarrow 1^-} f(x)$, where $f(x) = \begin{cases} \sqrt{1 - x^2} & 0 \leq x < 1 \\ 1 & 1 \leq x < 4 \\ 4 & x = 4 \end{cases}$

174) _____

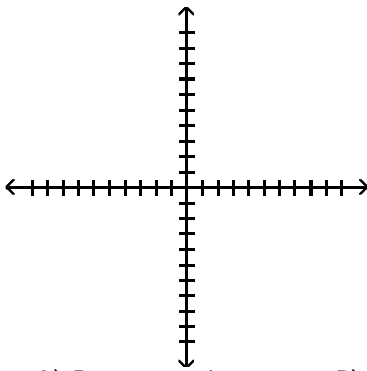

- A) Does not exist B) 1 C) 0 D) 4

175) $\lim_{x \rightarrow -7^+} f(x)$, where $f(x) = \begin{cases} x & -7 \leq x < 0, \text{ or } 0 < x \leq 3 \\ 1 & x = 0 \\ 0 & x < -7 \text{ or } x > 3 \end{cases}$

175) _____

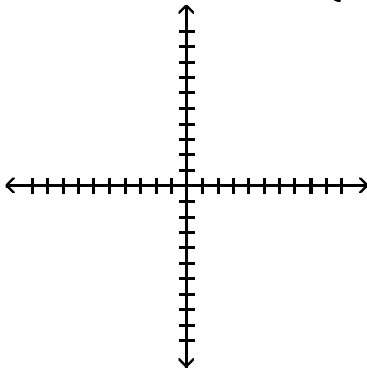

- A) 6 B) Does not exist C) -0 D) -7

Find the limit.

176) $\lim_{x \rightarrow -0.5^-} \sqrt{\frac{x+5}{x+6}}$

176) _____

- A) Does not exist B) $\frac{9}{11}$ C) $\sqrt{\frac{11}{13}}$ D) $\sqrt{\frac{9}{11}}$

177) $\lim_{x \rightarrow -1^+} \sqrt{\frac{7x^2}{2+x}}$

177) _____

- A) Does not exist B) $\sqrt{-7}$ C) $\sqrt{7}$ D) 7

178) $\lim_{x \rightarrow 2^+} \left(\frac{x}{x+2} \right) \left(\frac{3x+6}{x^2+2x} \right)$

178) _____

- A) $\frac{1}{3}$ B) $\frac{3}{2}$ C) $\frac{3}{4}$ D) Does not exist

179) $\lim_{h \rightarrow 0^+} \frac{\sqrt{h^2 + 7h + 13} - \sqrt{13}}{h}$

179) _____

- A) $\frac{7}{26}$ B) $\frac{7}{\sqrt{26}}$ C) $\frac{7}{2\sqrt{13}}$ D) Does not exist

180) $\lim_{h \rightarrow 0^-} \frac{\sqrt{5} - \sqrt{3h^2 + 7h + 5}}{h}$

180) _____

- A) $\frac{-7}{2\sqrt{5}}$ B) $\frac{7}{2\sqrt{5}}$ C) $\frac{-7}{\sqrt{10}}$ D) Does not exist

181) $\lim_{x \rightarrow -1^+} (x+3) \left(\frac{|x+1|}{x+1} \right)$

181) _____

- A) 4 B) 2 C) Does not exist D) -2

182) $\lim_{x \rightarrow -2^-} (x+5) \left(\frac{\lfloor x+2 \rfloor}{x+2} \right)$ 182) _____
 A) 7 B) Does not exist C) 3 D) -3

183) $\lim_{x \rightarrow 2^-} \frac{\sqrt{5x}(x-2)}{|x-2|}$ 183) _____
 A) Does not exist B) $\sqrt{10}$ C) $-\sqrt{10}$ D) 0

184) $\lim_{x \rightarrow 4^+} \frac{\sqrt{2x}(x-4)}{|x-4|}$ 184) _____
 A) 0 B) $\sqrt{8}$ C) $-\sqrt{8}$ D) Does not exist

Use the graph of the greatest integer function $y = \lfloor x \rfloor$ to find the limit.

185) $\lim_{x \rightarrow 7^-} \frac{\lfloor x \rfloor}{x}$ 185) _____
 A) 1 B) 7 C) 0 D) -7

186) $\lim_{x \rightarrow 2^+} (x - \lfloor x \rfloor)$ 186) _____
 A) 4 B) 0 C) -4 D) 2

Find the limit using $\lim_{x \rightarrow 0} \frac{\sin x}{x} = 1$.

187) $\lim_{x \rightarrow 0} \frac{\sin 5x}{x}$ 187) _____
 A) 1 B) does not exist C) $\frac{1}{5}$ D) 5

188) $\lim_{x \rightarrow 0} \frac{x}{\sin 3x}$ 188) _____
 A) $\frac{1}{3}$ B) 3 C) 1 D) does not exist

189) $\lim_{x \rightarrow 0} \frac{\tan 4x}{x}$ 189) _____
 A) 1 B) does not exist C) 4 D) $\frac{1}{4}$

190) $\lim_{x \rightarrow 0} \frac{\sin 5x}{\sin 4x}$ 190) _____
 A) 0 B) does not exist C) $\frac{5}{4}$ D) $\frac{4}{5}$

- 191) $\lim_{x \rightarrow 0} \frac{\sin 4x}{\sin 5x}$ 191) _____
 A) $\frac{4}{5}$ B) $\frac{5}{4}$ C) 0 D) does not exist
- 192) $\lim_{x \rightarrow 0} \frac{\sin x \cos 4x}{x + x \cos 5x}$ 192) _____
 A) $\frac{4}{5}$ B) $\frac{1}{2}$ C) 0 D) does not exist
- 193) $\lim_{x \rightarrow 0} 6x^2(\cot 3x)(\csc 2x)$ 193) _____
 A) $\frac{1}{3}$ B) does not exist C) 1 D) $\frac{1}{2}$
- 194) $\lim_{x \rightarrow 0} \frac{x^2 - 2x + \sin x}{x}$ 194) _____
 A) does not exist B) -1 C) 0 D) 1
- 195) $\lim_{x \rightarrow 0} \frac{\sin(\sin x)}{\sin x}$ 195) _____
 A) 0 B) does not exist C) 1 D) -1
- 196) $\lim_{x \rightarrow 0} \frac{\sin 3x \cot 4x}{\cot 5x}$ 196) _____
 A) 0 B) $\frac{12}{5}$ C) $\frac{15}{4}$ D) does not exist

Provide an appropriate response.

- 197) Given $\lim_{x \rightarrow 0^-} f(x) = L_I$, $\lim_{x \rightarrow 0^+} f(x) = L_R$, and $L_I \neq L_R$, which of the following statements is true? 197) _____
- I. $\lim_{x \rightarrow 0} f(x) = L_I$
 II. $\lim_{x \rightarrow 0} f(x) = L_R$
 III. $\lim_{x \rightarrow 0} f(x)$ does not exist.
- A) none B) III C) II D) I

- 198) Given $\lim_{x \rightarrow 0^-} f(x) = L_L$, $\lim_{x \rightarrow 0^+} f(x) = L_R$, and $L_L = L_R$, which of the following statements is false? 198) _____
- I. $\lim_{x \rightarrow 0} f(x) = L_L$
 II. $\lim_{x \rightarrow 0} f(x) = L_R$
 III. $\lim_{x \rightarrow 0} f(x)$ does not exist.
- A) II B) none C) I D) III
- 199) If $\lim_{x \rightarrow 0} f(x) = L$, which of the following expressions are true? 199) _____
- I. $\lim_{x \rightarrow 0^-} f(x)$ does not exist.
 II. $\lim_{x \rightarrow 0^+} f(x)$ does not exist.
 III. $\lim_{x \rightarrow 0^-} f(x) = L$
 IV. $\lim_{x \rightarrow 0^+} f(x) = L$
- A) III and IV only B) I and IV only C) II and III only D) I and II only
- 200) If $\lim_{x \rightarrow 0^-} f(x) = 1$ and $f(x)$ is an odd function, which of the following statements are true? 200) _____
- I. $\lim_{x \rightarrow 0} f(x) = 1$
 II. $\lim_{x \rightarrow 0^+} f(x) = -1$
 III. $\lim_{x \rightarrow 0} f(x)$ does not exist.
- A) II and III only B) I and III only C) I, II, and III D) I and II only
- 201) If $\lim_{x \rightarrow 1^-} f(x) = 1$, $\lim_{x \rightarrow 1^+} f(x) = -1$, and $f(x)$ is an even function, which of the following statements are true? 201) _____
- I. $\lim_{x \rightarrow -1^-} f(x) = -1$
 II. $\lim_{x \rightarrow -1^+} f(x) = -1$
 III. $\lim_{x \rightarrow -1} f(x)$ does not exist.
- A) I, II, and III B) II and III only C) I and II only D) I and III only
- 202) Given $\varepsilon > 0$, find an interval $I = (6, 6 + \delta)$, $\delta > 0$, such that if x lies in I , then $\sqrt{x - 6} < \varepsilon$. What limit is being verified and what is its value? 202) _____
- A) $\lim_{x \rightarrow 0^-} \sqrt{x - 6} = 0$ B) $\lim_{x \rightarrow 6^+} \sqrt{x} = 6$
 C) $\lim_{x \rightarrow 6^+} \sqrt{x - 6} = 0$ D) $\lim_{x \rightarrow 6^-} \sqrt{x - 6} = 0$

203) Given $\varepsilon > 0$, find an interval $I = (1 - \delta, 1)$, $\delta > 0$, such that if x lies in I , then $\sqrt{1 - x} < \varepsilon$. What limit is being verified and what is its value? 203) _____

A) $\lim_{x \rightarrow 1^-} \sqrt{1 - x} = 0$

B) $\lim_{x \rightarrow 1^+} \sqrt{1 - x} = 0$

C) $\lim_{x \rightarrow 0^-} \sqrt{1 - x} = 0$

D) $\lim_{x \rightarrow 1^-} \sqrt{x} = 1$

Find all points where the function is discontinuous.

204) _____ 204) _____

A) None

B) $x = 2$

C) $x = 4$

D) $x = 4, x = 2$

205) _____ 205) _____

A) $x = -2$

B) $x = -2, x = 1$

C) None

D) $x = 1$

206) _____ 206) _____

A) $x = -2, x = 0$

B) $x = 0, x = 2$

C) $x = -2, x = 0, x = 2$

D) $x = 2$

207) _____ 207) _____

A) $x = 6$

B) $x = -2$

C) $x = -2, x = 6$

D) None

208)

208) _____

- A) $x = 1, x = 4, x = 5$
- C) None

- B) $x = 4$
- D) $x = 1, x = 5$

209)

209) _____

A) $x = 1$

B) None

C) $x = 0$

D) $x = 0, x = 1$

210)

210) _____

A) $x = 3$

B) $x = 0$

C) None

D) $x = 0, x = 3$

211)

211) _____

A) None

B) $x = 2$

C) $x = -2$

D) $x = -2, x = 2$

212)

212) _____

- A) $x = -2, x = 2$
- C) None

- B) $x = -2, x = 0, x = 2$
- D) $x = 0$

Answer the question.

213) Does $\lim_{x \rightarrow (-1)^+} f(x)$ exist?

213) _____

$$f(x) = \begin{cases} -x^2 + 1, & -1 \leq x < 0 \\ 4x, & 0 < x < 1 \\ -4, & x = 1 \\ -4x + 8, & 1 < x < 3 \\ 1, & 3 < x < 5 \end{cases}$$

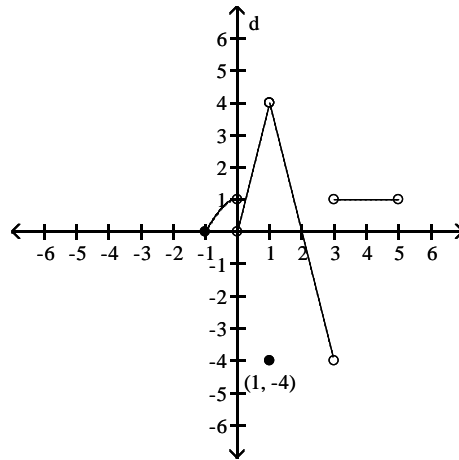

A) Yes

B) No

214) Does $\lim_{x \rightarrow -1^+} f(x) = f(-1)$?

214) _____

$$f(x) = \begin{cases} -x^2 + 1, & -1 \leq x < 0 \\ 2x, & 0 < x < 1 \\ -5, & x = 1 \\ -2x + 4, & 1 < x < 3 \\ 4, & 3 < x < 5 \end{cases}$$

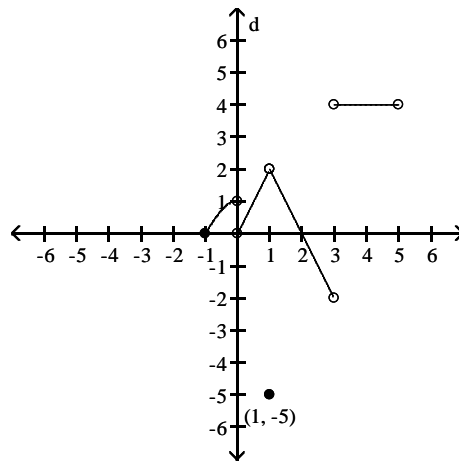

A) Yes

B) No

215) Does $\lim_{x \rightarrow 1} f(x)$ exist?

215) _____

$$f(x) = \begin{cases} -x^2 + 1, & -1 \leq x < 0 \\ 3x, & 0 < x < 1 \\ -4, & x = 1 \\ -3x + 6, & 1 < x < 3 \\ 3, & 3 < x < 5 \end{cases}$$

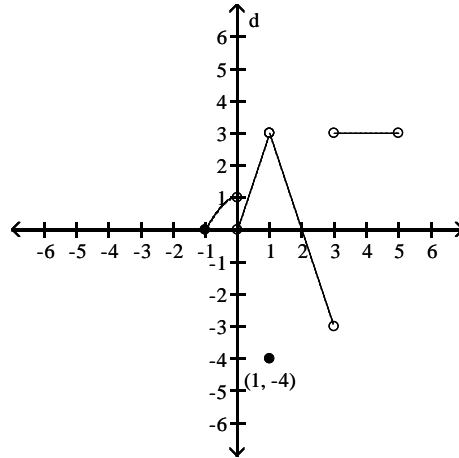

A) No

B) Yes

216) Is f continuous at $f(1)$?

216) _____

$$f(x) = \begin{cases} -x^2 + 1, & -1 \leq x < 0 \\ 3x, & 0 < x < 1 \\ -3, & x = 1 \\ -3x + 6, & 1 < x < 3 \\ 4, & 3 < x < 5 \end{cases}$$

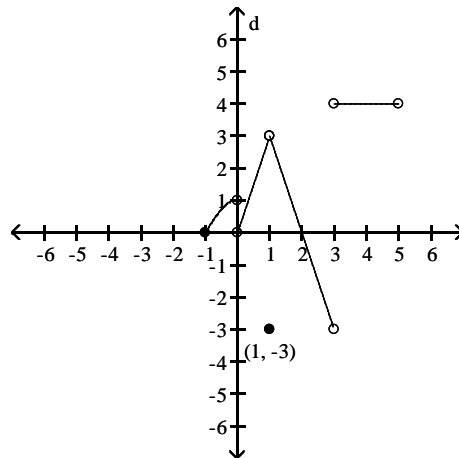

A) No

B) Yes

217) Is f continuous at $f(3)$?

217) _____

$$f(x) = \begin{cases} -x^2 + 1, & -1 \leq x < 0 \\ 5x, & 0 < x < 1 \\ -2, & x = 1 \\ -5x + 10, & 1 < x < 3 \\ 4, & 3 < x < 5 \end{cases}$$

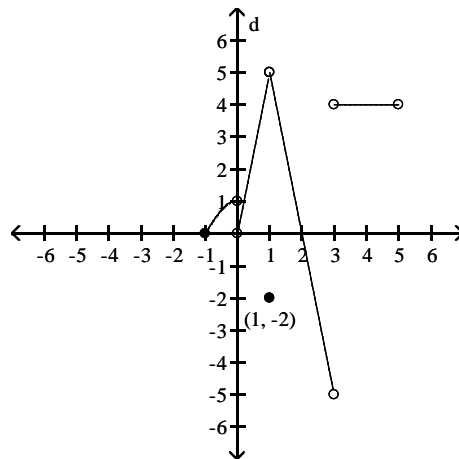

A) No

B) Yes

218) Does $\lim_{x \rightarrow 0} f(x)$ exist?

218) _____

$$f(x) = \begin{cases} x^3, & -2 < x \leq 0 \\ -4x, & 0 \leq x < 2 \\ 7, & 2 < x \leq 4 \\ 0, & x = 2 \end{cases}$$

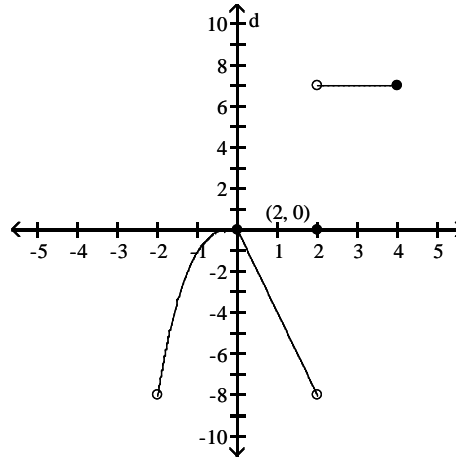

A) No

B) Yes

219) Does $\lim_{x \rightarrow 2} f(x) = f(2)$?

219) _____

$$f(x) = \begin{cases} x^3, & -2 < x \leq 0 \\ -2x, & 0 \leq x < 2 \\ 4, & 2 < x \leq 4 \\ 0, & x = 2 \end{cases}$$

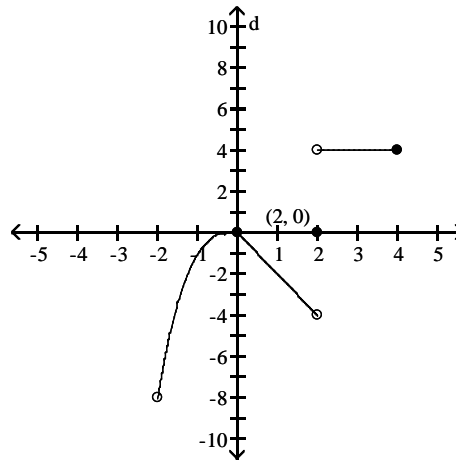

A) No

B) Yes

220) Is f continuous at $x = 0$?

220) _____

$$f(x) = \begin{cases} x^3, & -2 < x \leq 0 \\ -2x, & 0 \leq x < 2 \\ 6, & 2 < x \leq 4 \\ 0, & x = 2 \end{cases}$$

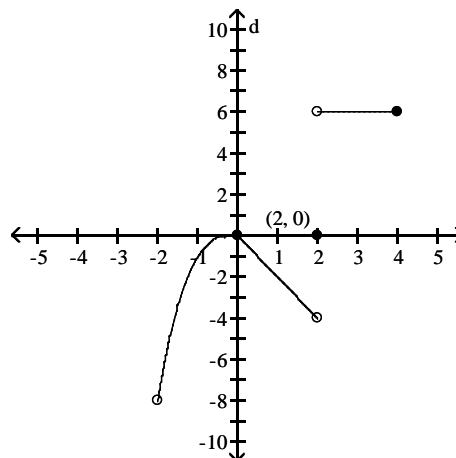

A) Yes

B) No

221) Is f continuous at $x = 4$?

221) _____

$$f(x) = \begin{cases} x^3, & -2 < x \leq 0 \\ -2x, & 0 \leq x < 2 \\ 6, & 2 < x \leq 4 \\ 0, & x = 2 \end{cases}$$

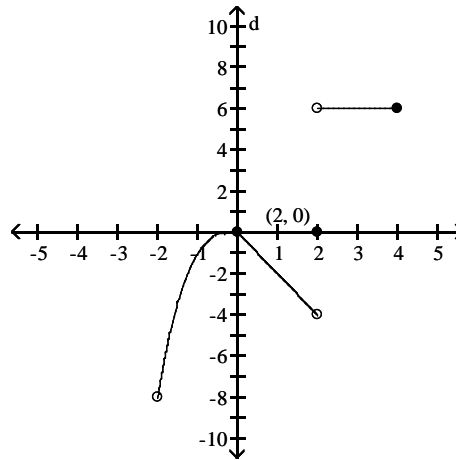

A) Yes

B) No

222) Is f continuous on $(-2, 4]$?

222) _____

$$f(x) = \begin{cases} x^3, & -2 < x \leq 0 \\ -4x, & 0 \leq x < 2 \\ 2, & 2 < x \leq 4 \\ 0, & x = 2 \end{cases}$$

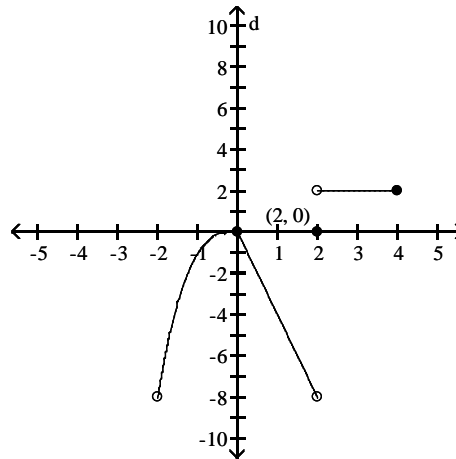

A) No

B) Yes

Solve the problem.

223) To what new value should $f(1)$ be changed to remove the discontinuity?

223) _____

$$f(x) = \begin{cases} x^2 + 2, & x < 1 \\ 1, & x = 1 \\ x + 2, & x > 1 \end{cases}$$

A) 4

B) 3

C) 2

D) 1

224) To what new value should $f(2)$ be changed to remove the discontinuity?

224) _____

$$f(x) = \begin{cases} 2x - 4, & x < 2 \\ 2, & x = 2 \\ x - 2, & x > 2 \end{cases}$$

A) -8

B) 0

C) -7

D) -1

Find the intervals on which the function is continuous.

225) $y = \frac{2}{x+5} - 4x$

225) _____

A) continuous everywhere

B) discontinuous only when $x = -5$

C) discontinuous only when $x = -9$

D) discontinuous only when $x = 5$

- 226) $y = \frac{1}{(x+2)^2 + 4}$ 226) _____
 A) discontinuous only when $x = 8$ B) discontinuous only when $x = -16$
 C) discontinuous only when $x = -2$ D) continuous everywhere
- 227) $y = \frac{x+2}{x^2 - 8x + 7}$ 227) _____
 A) discontinuous only when $x = 1$ or $x = 7$ B) discontinuous only when $x = 1$
 C) discontinuous only when $x = -7$ or $x = 1$ D) discontinuous only when $x = -1$ or $x = 7$
- 228) $y = \frac{3}{x^2 - 9}$ 228) _____
 A) discontinuous only when $x = -9$ or $x = 9$ B) discontinuous only when $x = -3$
 C) discontinuous only when $x = 9$ D) discontinuous only when $x = -3$ or $x = 3$
- 229) $y = \frac{2}{|x| + 3} - \frac{x^2}{7}$ 229) _____
 A) discontinuous only when $x = -3$ B) continuous everywhere
 C) discontinuous only when $x = -7$ or $x = -3$ D) discontinuous only when $x = -10$
- 230) $y = \frac{\sin(4\theta)}{2\theta}$ 230) _____
 A) continuous everywhere B) discontinuous only when $\theta = \frac{\pi}{2}$
 C) discontinuous only when $\theta = \pi$ D) discontinuous only when $\theta = 0$
- 231) $y = \frac{2 \cos \theta}{\theta + 8}$ 231) _____
 A) continuous everywhere B) discontinuous only when $\theta = -8$
 C) discontinuous only when $\theta = \frac{\pi}{2}$ D) discontinuous only when $\theta = 8$
- 232) $y = \sqrt{4x + 2}$ 232) _____
 A) continuous on the interval $\left[-\frac{1}{2}, \infty\right)$ B) continuous on the interval $\left[-\frac{1}{2}, \infty\right)$
 C) continuous on the interval $\left[\frac{1}{2}, \infty\right)$ D) continuous on the interval $\left[-\infty, -\frac{1}{2}\right]$
- 233) $y = \sqrt[4]{10x - 1}$ 233) _____
 A) continuous on the interval $\left[-\frac{1}{10}, \infty\right)$ B) continuous on the interval $\left[\frac{1}{10}, \infty\right)$
 C) continuous on the interval $\left[\frac{1}{10}, \infty\right)$ D) continuous on the interval $\left[-\infty, \frac{1}{10}\right]$

- 234) $y = \sqrt{x^2 - 5}$ 234) _____
- A) continuous everywhere
 B) continuous on the interval $[-\sqrt{5}, \sqrt{5}]$
 C) continuous on the interval $[\sqrt{5}, \infty)$
 D) continuous on the intervals $(-\infty, -\sqrt{5}]$ and $[\sqrt{5}, \infty)$

Find the limit and determine if the function is continuous at the point being approached.

- 235) $\lim_{x \rightarrow 4\pi} \sin(4x - \sin 4x)$ 235) _____
- A) 0; yes
 B) does not exist; yes
 C) does not exist; no
 D) 0; no

- 236) $\lim_{x \rightarrow -\pi/2} \cos(5x - \cos 5x)$ 236) _____
- A) 0; yes
 B) does not exist; yes
 C) does not exist; no
 D) 0; no

- 237) $\lim_{x \rightarrow 2\pi} \sin\left(\frac{-3\pi}{2} \cos(\tan x)\right)$ 237) _____
- A) 1; yes
 B) 1; no
 C) does not exist; no
 D) does not exist; yes

- 238) $\lim_{x \rightarrow -3\pi/2} \cos\left(\frac{5\pi}{2} \cos(\tan x)\right)$ 238) _____
- A) does not exist; no
 B) 1; yes
 C) 1; no
 D) does not exist; yes

- 239) $\lim_{x \rightarrow 9} \sec(x \sec^2 x - x \tan^2 x - 1)$ 239) _____
- A) does not exist; no
 B) sec 8; yes
 C) csc 8; yes
 D) sec 8; no

- 240) $\lim_{x \rightarrow 6} \sin(x \sin^2 x + x \cos^2 x + 2)$ 240) _____
- A) sin 8; no
 B) does not exist; no
 C) sin -4; yes
 D) sin 8; yes

- 241) $\lim_{\theta \rightarrow -\pi} \tan\left(\frac{-\pi}{4} \cos(\sin \theta)\right)$ 241) _____
- A) -1; yes
 B) 0; yes
 C) does not exist; no
 D) -1; no

- 242) $\lim_{\theta \rightarrow -\pi} \tan(\sin(-\pi \cos(\sin \theta)))$ 242) _____
- A) does not exist; no
 B) 1; yes
 C) 0; no
 D) 0; yes

243) $\lim_{x \rightarrow 1} \cos\left(\frac{\pi}{3} \ln(e^x)\right)$ 243) _____

A) 1; yes B) $\frac{1}{2}$; no

C) does not exist; no D) $\frac{1}{2}$; yes

244) $\lim_{x \rightarrow 0} \sin^{-1}(e^{x^3})$ 244) _____

A) $\frac{\pi}{2}$; yes B) $\frac{\pi}{4}$; yes

C) $\frac{\pi}{4}$; no D) does not exist; no

Determine if the given function can be extended to a continuous function at $x = 0$. If so, approximate the extended function's value at $x = 0$ (rounded to four decimal places if necessary). If not, determine whether the function can be continuously extended from the left or from the right and provide the values of the extended functions at $x = 0$. Otherwise write "no continuous extension."

245) $f(x) = \frac{10^{2x} - 1}{x}$ 245) _____

A) No continuous extension B) $f(0) = 0$ only from the right

C) $f(0) = 0$ D) $f(0) = 0$ only from the left

246) $f(x) = \frac{\cos 2x}{|2x|}$ 246) _____

A) $f(0) = 2$ B) No continuous extension

C) $f(0) = 2$ only from the left D) $f(0) = 2$ only from the right

247) $f(x) = (1 + 2x)^{1/x}$ 247) _____

A) $f(0) = 5.4366$ B) No continuous extension

C) $f(0) = 7.3891$ D) $f(0) = 2.7183$

248) $f(x) = \frac{\tan x}{x}$ 248) _____

A) $f(0) = 1$ only from the left B) $f(0) = 1$

C) $f(0) = 1$ only from the right D) No continuous extension

Find numbers a and b , or k , so that f is continuous at every point.

249) 249) _____

$$f(x) = \begin{cases} 8, & x < -4 \\ ax + b, & -4 \leq x \leq 4 \\ -24, & x > 4 \end{cases}$$

A) $a = -4, b = -8$ B) $a = 8, b = -24$ C) $a = -4, b = -40$ D) Impossible

250) 250) _____

$$f(x) = \begin{cases} x^2, & x < 3 \\ ax + b, & 3 \leq x \leq 5 \\ x + 20, & x > 5 \end{cases}$$

A) $a = -8, b = -15$ B) $a = 8, b = -15$ C) $a = 8, b = 15$ D) Impossible

251) 251) _____

$$f(x) = \begin{cases} 8x + 3, & \text{if } x < -1 \\ kx + 2, & \text{if } x \geq -1 \end{cases}$$

A) $k = 7$ B) $k = -2$ C) $k = 2$ D) $k = 9$

252) 252) _____

$$f(x) = \begin{cases} x^2, & \text{if } x \leq 5 \\ x + k, & \text{if } x > 5 \end{cases}$$

A) $k = 20$ B) $k = 30$ C) $k = -5$ D) Impossible

253) 253) _____

$$f(x) = \begin{cases} x^2, & \text{if } x \leq 10 \\ kx, & \text{if } x > 10 \end{cases}$$

A) $k = \frac{1}{10}$ B) $k = 100$ C) $k = 10$ D) Impossible

SHORT ANSWER. Write the word or phrase that best completes each statement or answers the question.

Provide an appropriate response.

254) Use the Intermediate Value Theorem to prove that $5x^3 - 8x^2 + 4x - 3 = 0$ has a solution between 1 and 2. 254) _____

255) Use the Intermediate Value Theorem to prove that $10x^4 + 6x^3 - 9x - 6 = 0$ has a solution between -1 and 0. 255) _____

256) Use the Intermediate Value Theorem to prove that $x(x - 3)^2 = 3$ has a solution between 2 and 4. 256) _____

257) Use the Intermediate Value Theorem to prove that $3 \sin x = x$ has a solution between $\frac{\pi}{2}$ and π . 257) _____

MULTIPLE CHOICE. Choose the one alternative that best completes the statement or answers the question.

- 258) Use a calculator to graph the function f to see whether it appears to have a continuous extension to the origin. If it does, use Trace and Zoom to find a good candidate for the extended function's value at $x = 0$. If the function does not appear to have a continuous extension, can it be extended to be continuous at the origin from the right or from the left? If so, what do you think the extended function's value(s) should be? 258) _____

$$f(x) = \frac{7^x - 1}{x}$$

- A) continuous extension exists at origin; $f(0) = 0$
- B) continuous extension exists from the left; $f(0) \approx 1.9556$
- C) continuous extension exists from the right; $f(0) \approx 1.9556$
- D) continuous extension exists at origin; $f(0) \approx 1.9556$

- 259) Use a calculator to graph the function f to see whether it appears to have a continuous extension to the origin. If it does, use Trace and Zoom to find a good candidate for the extended function's value at $x = 0$. If the function does not appear to have a continuous extension, can it be extended to be continuous at the origin from the right or from the left? If so, what do you think the extended function's value(s) should be? 259) _____

$$f(x) = \frac{7 \sin x}{|x|}$$

- A) continuous extension exists at origin; $f(0) = 0$
- B) continuous extension exists at origin; $f(0) = 7$
- C) continuous extension exists from the right; $f(0) = 7$
continuous extension exists from the left; $f(0) = -7$
- D) continuous extension exists from the right; $f(0) = 1$
continuous extension exists from the left; $f(0) = -1$

SHORT ANSWER. Write the word or phrase that best completes each statement or answers the question.

- 260) A function $y = f(x)$ is continuous on $[1, 2]$. It is known to be positive at $x = 1$ and negative at $x = 2$. What, if anything, does this indicate about the equation $f(x) = 0$? Illustrate with a sketch. 260) _____

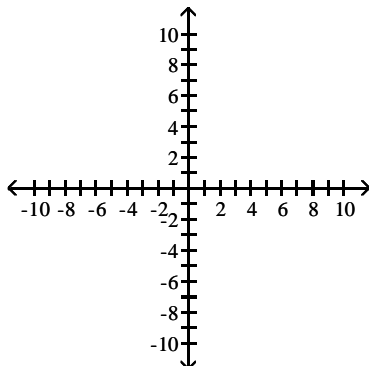

- 261) Explain why the following five statements ask for the same information. 261) _____
- (a) Find the roots of $f(x) = 2x^3 - 1x - 3$.
- (b) Find the x-coordinate of the points where the curve $y = 2x^3$ crosses the line $y = 1x + 3$.
- (c) Find all the values of x for which $2x^3 - 1x = 3$.
- (d) Find the x-coordinates of the points where the cubic curve $y = 2x^3 - 1x$ crosses the line $y = 3$.
- (e) Solve the equation $2x^3 - 1x - 3 = 0$.
- 262) If $f(x) = 2x^3 - 5x + 5$, show that there is at least one value of c for which $f(x)$ equals π . 262) _____
- 263) If functions $f(x)$ and $g(x)$ are continuous for $0 \leq x \leq 2$, could $\frac{f(x)}{g(x)}$ possibly be discontinuous 263) _____
at a point of $[0,2]$? Provide an example.
- 264) Give an example of a function $f(x)$ that is continuous at all values of x except at $x = 10$, 264) _____
where it has a removable discontinuity. Explain how you know that f is discontinuous at $x = 10$ and how you know the discontinuity is removable.
- 265) Give an example of a function $f(x)$ that is continuous for all values of x except $x = 4$, where 265) _____
it has a nonremovable discontinuity. Explain how you know that f is discontinuous at $x = 4$ and why the discontinuity is nonremovable.

MULTIPLE CHOICE. Choose the one alternative that best completes the statement or answers the question.

For the function f whose graph is given, determine the limit.

- 266) Find $\lim_{x \rightarrow -1^-} f(x)$ and $\lim_{x \rightarrow -1^+} f(x)$. 266) _____

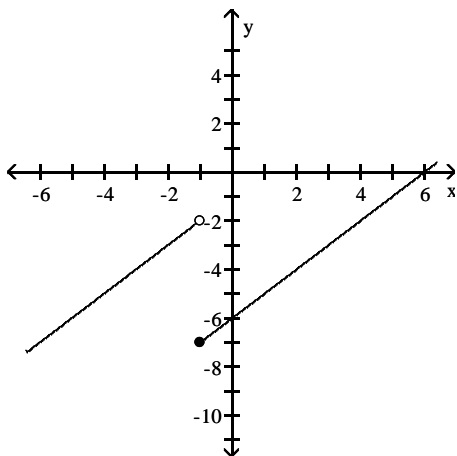

- A) -5; -2 B) -7; -2 C) -7; -5 D) -2; -7

267) Find $\lim_{x \rightarrow 2^-} f(x)$ and $\lim_{x \rightarrow 2^+} f(x)$.

267) _____

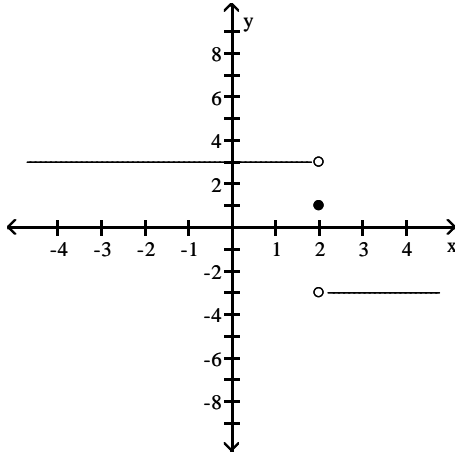

- A) -3; 3
- C) 1; 1

- B) does not exist; does not exist
- D) 3; -3

268) Find $\lim_{x \rightarrow 2^-} f(x)$.

268) _____

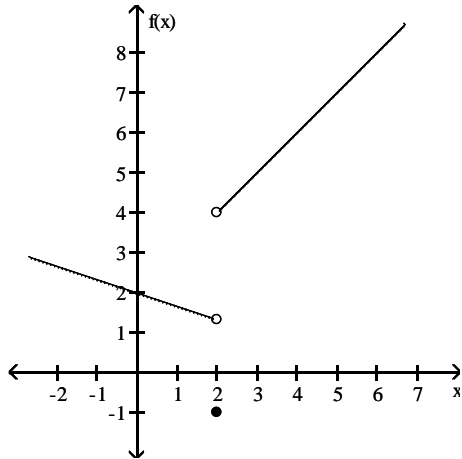

A) 4

B) -1

C) 2.3

D) 1.3

269) Find $\lim_{x \rightarrow 1^-} f(x)$.

269) _____

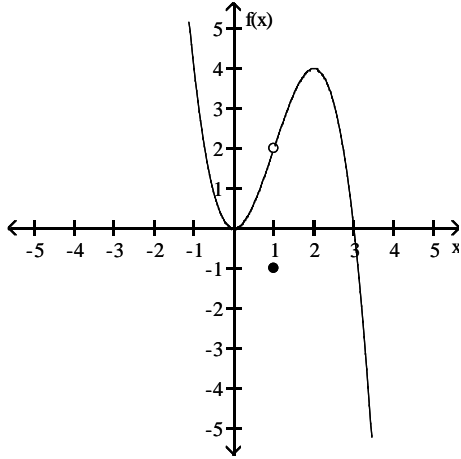

- A) -1 B) does not exist C) 2 D) $\frac{1}{2}$

270) Find $\lim_{x \rightarrow 1^+} f(x)$.

270) _____

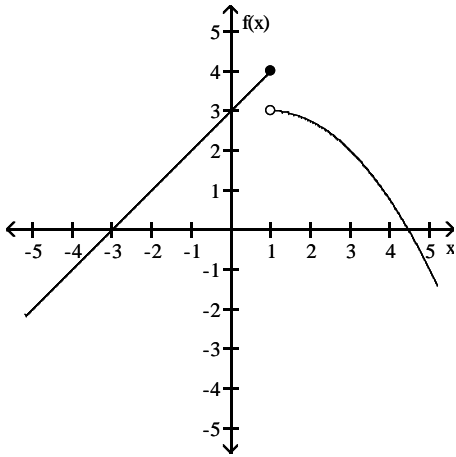

- A) $3\frac{1}{2}$ B) does not exist C) 4 D) 3

271) Find $\lim_{x \rightarrow 0} f(x)$.

271) _____

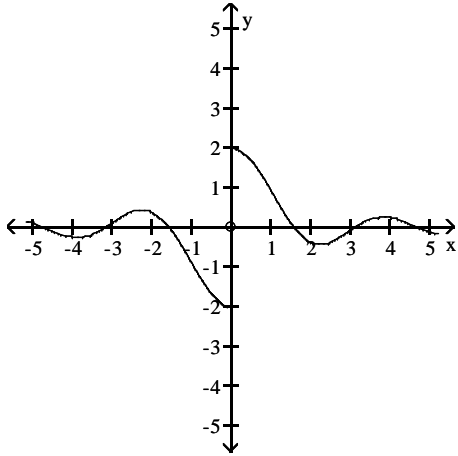

- A) does not exist B) -2 C) 0 D) 2

272) Find $\lim_{x \rightarrow 0} f(x)$.

272) _____

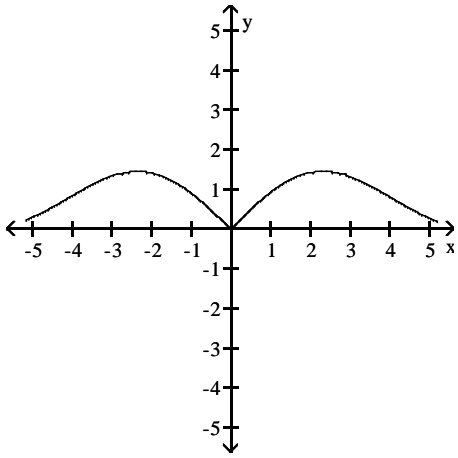

- A) 0 B) -2 C) 2 D) does not exist

273) Find $\lim_{x \rightarrow 0} f(x)$.

273) _____

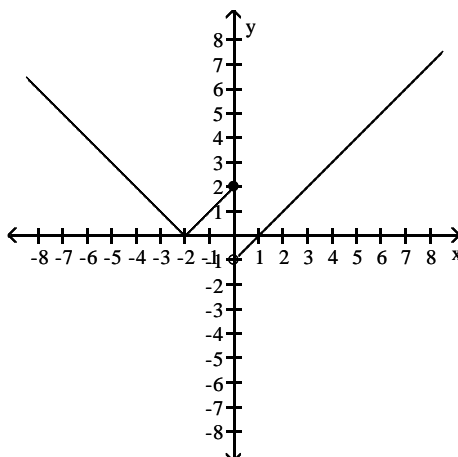

- A) -2 B) 0 C) 2 D) does not exist

274) Find $\lim_{x \rightarrow -1} f(x)$.

274) _____

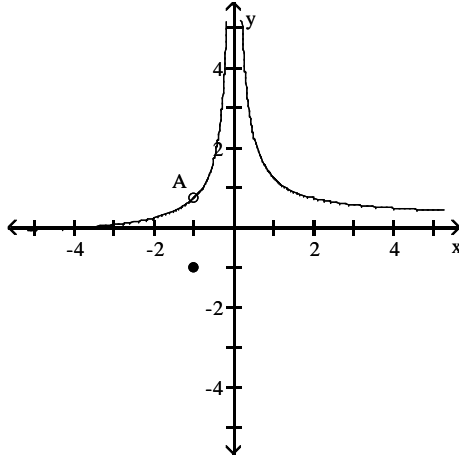

- A) does not exist B) $-\frac{3}{4}$ C) $\frac{3}{4}$ D) -1

275) Find $\lim_{x \rightarrow -\infty} f(x)$.

275) _____

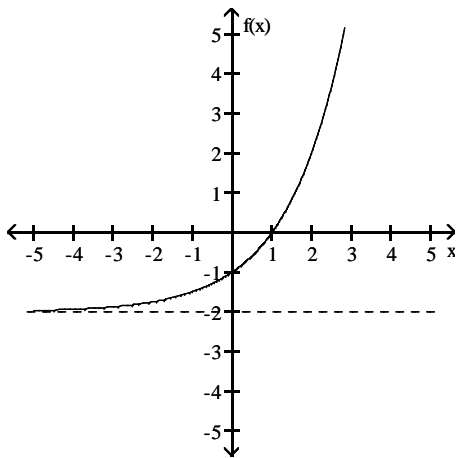

- A) -2 B) does not exist C) $-\infty$ D) 0

Find the limit.

276) $\lim_{x \rightarrow \infty} \frac{1}{x} - 4$

276) _____

- A) -4 B) 4 C) -3 D) -5

277) $\lim_{x \rightarrow -\infty} \frac{8}{8 - (6/x^2)}$

277) _____

- A) 8 B) 4 C) 1 D) $-\infty$

278) $\lim_{x \rightarrow -\infty} \frac{-4 + (3/x)}{6 - (1/x^2)}$

278) _____

- A) $-\frac{2}{3}$ B) $-\infty$ C) ∞ D) $\frac{2}{3}$

279) $\lim_{x \rightarrow \infty} \frac{x^2 - 8x + 19}{x^3 + 3x^2 + 18}$ 279) _____
 A) 0 B) 1 C) $\frac{19}{18}$ D) ∞

280) $\lim_{x \rightarrow -\infty} \frac{-11x^2 + 2x + 15}{-10x^2 - 2x + 18}$ 280) _____
 A) $\frac{5}{6}$ B) ∞ C) $\frac{11}{10}$ D) 1

281) $\lim_{x \rightarrow \infty} \frac{2x + 1}{12x - 7}$ 281) _____
 A) $\frac{1}{6}$ B) ∞ C) 0 D) $-\frac{1}{7}$

282) $\lim_{x \rightarrow \infty} \frac{7x^3 - 6x^2 + 3x}{-x^3 - 2x + 7}$ 282) _____
 A) ∞ B) $\frac{3}{2}$ C) 7 D) -7

283) $\lim_{x \rightarrow -\infty} \frac{4x^3 + 2x^2}{x - 6x^2}$ 283) _____
 A) 4 B) $-\frac{1}{3}$ C) ∞ D) $-\infty$

284) $\lim_{x \rightarrow -\infty} \frac{\cos 4x}{x}$ 284) _____
 A) 1 B) 4 C) 0 D) $-\infty$

Divide numerator and denominator by the highest power of x in the denominator to find the limit.

285) $\lim_{x \rightarrow \infty} \sqrt{\frac{25x^2}{2 + 36x^2}}$ 285) _____
 A) $\frac{25}{36}$ B) $\frac{5}{6}$ C) $\frac{25}{2}$ D) does not exist

286) $\lim_{x \rightarrow \infty} \sqrt{\frac{16x^2 + x - 3}{(x - 9)(x + 1)}}$ 286) _____
 A) 4 B) 0 C) 16 D) ∞

287) $\lim_{x \rightarrow \infty} \frac{5\sqrt{x} + x^{-1}}{5x + 5}$ 287) _____
 A) 1 B) 0 C) $\frac{1}{5}$ D) ∞

288) $\lim_{x \rightarrow \infty} \frac{4x-1-3x^{-3}}{4x^{-2}+x^{-5}}$ 288) _____
 A) $-\infty$ B) 1 C) 0 D) ∞

289) $\lim_{x \rightarrow -\infty} \frac{\sqrt[3]{x+2x-3}}{-5x+x^{2/3}+3}$ 289) _____
 A) $-\infty$ B) $-\frac{5}{2}$ C) $-\frac{2}{5}$ D) 0

290) $\lim_{t \rightarrow \infty} \frac{\sqrt{49t^2-343}}{t-7}$ 290) _____
 A) does not exist B) 49 C) 343 D) 7

291) $\lim_{t \rightarrow \infty} \frac{\sqrt{36t^2-216}}{t-6}$ 291) _____
 A) 216 B) 36 C) does not exist D) 6

292) $\lim_{x \rightarrow \infty} \frac{5x+6}{\sqrt{6x^2+1}}$ 292) _____
 A) 0 B) ∞ C) $\frac{5}{\sqrt{6}}$ D) $\frac{5}{6}$

Find the limit.

293) $\lim_{x \rightarrow -2} \frac{1}{x+2}$ 293) _____
 A) Does not exist B) 1/2 C) $-\infty$ D) ∞

294) $\lim_{x \rightarrow 5^-} \frac{1}{x-5}$ 294) _____
 A) $-\infty$ B) -1 C) 0 D) ∞

295) $\lim_{x \rightarrow -3^-} \frac{1}{x+3}$ 295) _____
 A) -1 B) ∞ C) 0 D) $-\infty$

296) $\lim_{x \rightarrow 10^+} \frac{1}{(x-10)^2}$ 296) _____
 A) 0 B) -1 C) ∞ D) $-\infty$

297) $\lim_{x \rightarrow -3^-} \frac{4}{x^2-9}$ 297) _____
 A) ∞ B) -1 C) 0 D) $-\infty$

- 298) $\lim_{x \rightarrow 2^+} \frac{4}{x^2 - 4}$ 298) _____
 A) $-\infty$ B) 0 C) 1 D) ∞
- 299) $\lim_{x \rightarrow 5^-} \frac{1}{x^2 - 25}$ 299) _____
 A) 1 B) ∞ C) 0 D) $-\infty$
- 300) $\lim_{x \rightarrow 0} \frac{1}{x^{2/3}}$ 300) _____
 A) $-\infty$ B) 0 C) $2/3$ D) ∞
- 301) $\lim_{x \rightarrow (\pi/2)^+} \tan x$ 301) _____
 A) $-\infty$ B) 1 C) ∞ D) 0
- 302) $\lim_{x \rightarrow (-\pi/2)^-} \sec x$ 302) _____
 A) 1 B) ∞ C) 0 D) $-\infty$
- 303) $\lim_{x \rightarrow 0^+} (1 + \csc x)$ 303) _____
 A) 0 B) 1 C) ∞ D) Does not exist
- 304) $\lim_{x \rightarrow 0} (1 - \cot x)$ 304) _____
 A) ∞ B) 0 C) $-\infty$ D) Does not exist
- 305) $\lim_{x \rightarrow 0^+} \frac{x^2}{2} - \frac{1}{x}$ 305) _____
 A) Does not exist B) 0 C) $-\infty$ D) ∞
- 306) $\lim_{x \rightarrow \sqrt[3]{7}} \frac{x^2}{7} - \frac{1}{x}$ 306) _____
 A) $-\infty$ B) $2\sqrt[3]{7}$ C) ∞ D) 0
- 307) $\lim_{x \rightarrow 2^-} \frac{x^2 - 5x + 6}{x^3 - 4x}$ 307) _____
 A) $-\infty$ B) 0 C) ∞ D) $-\frac{1}{8}$

308) $\lim_{x \rightarrow 0^-} \frac{x^2 - 6x + 8}{x^3 - 4x}$ 308) _____
 A) 0 B) $-\infty$ C) ∞ D) Does not exist

309) $\lim_{x \rightarrow 0^+} \left(\frac{1}{x^{1/3}} + 9 \right)$ 309) _____
 A) Does not exist B) $-\infty$ C) ∞ D) 9

310) $\lim_{x \rightarrow 0^-} \left(\frac{1}{x^{2/3}} + 1 \right)$ 310) _____
 A) 1 B) Does not exist C) ∞ D) $-\infty$

311) $\lim_{x \rightarrow 4^+} \left(\frac{1}{x^{2/5}} - \frac{1}{(x-4)^{2/5}} \right)$ 311) _____
 A) ∞ B) Does not exist C) 0 D) $-\infty$

312) $\lim_{x \rightarrow 1^-} \left(\frac{1}{x^{2/5}} - \frac{1}{(x-1)^{3/5}} \right)$ 312) _____
 A) Does not exist B) $-\infty$ C) ∞ D) 0

Graph the rational function. Include the graphs and equations of the asymptotes.

313) $y = \frac{x}{x-1}$ 313) _____

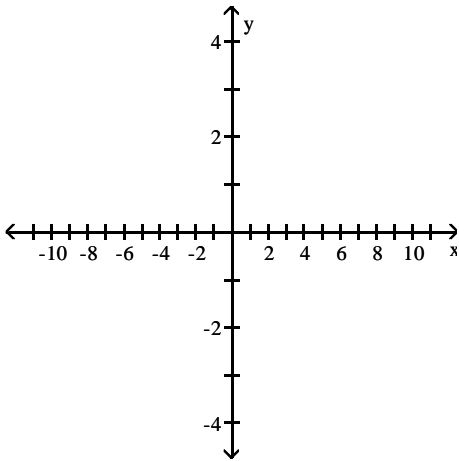

A) asymptotes: $x = 1, y = 0$

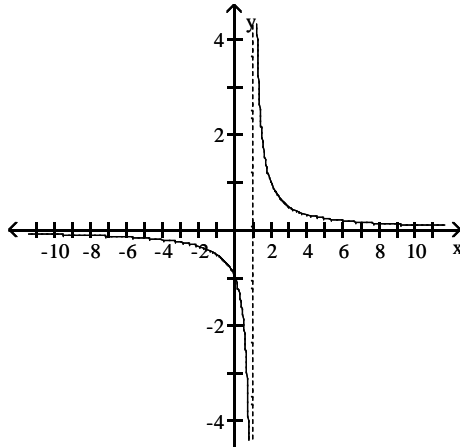

B) asymptotes: $x = -1, y = 0$

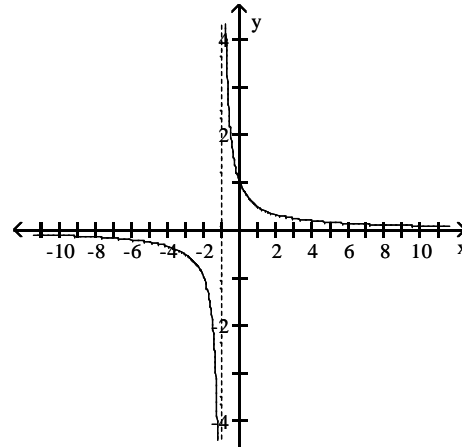

C) asymptotes: $x = -1, y = 1$

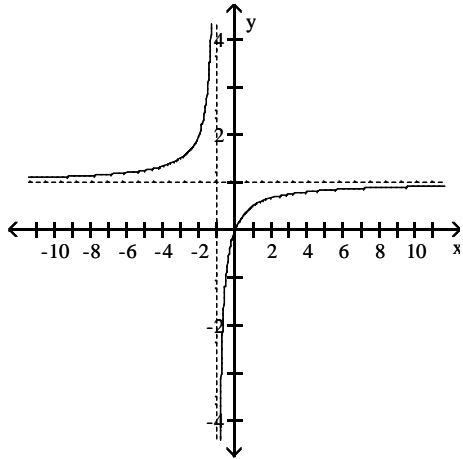

D) asymptotes: $x = 1, y = 1$

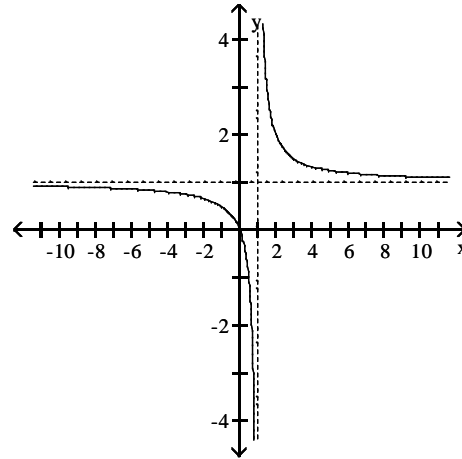

314) $y = \frac{x}{x^2 + x + 2}$

314) _____

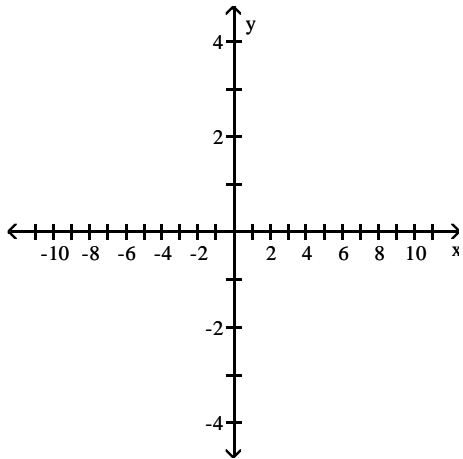

A) asymptotes: $x = 2$, $x = -2$

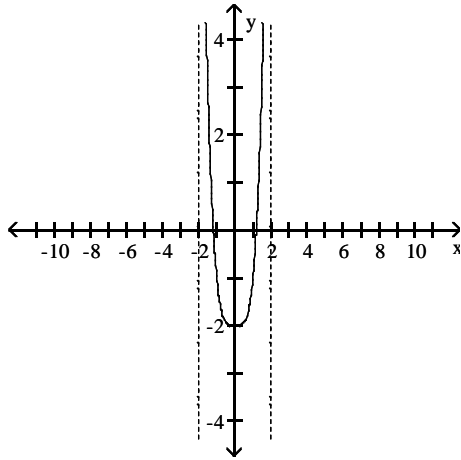

B) asymptote: $y = 0$

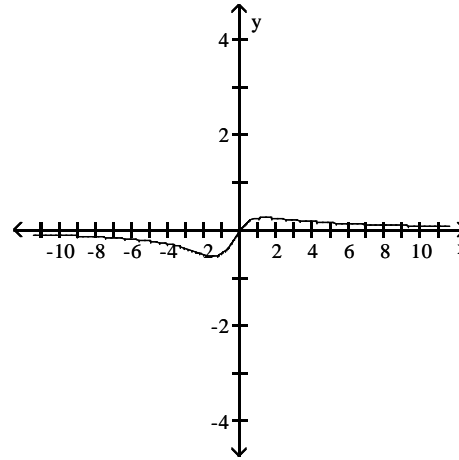

C) asymptote: $y = 0$

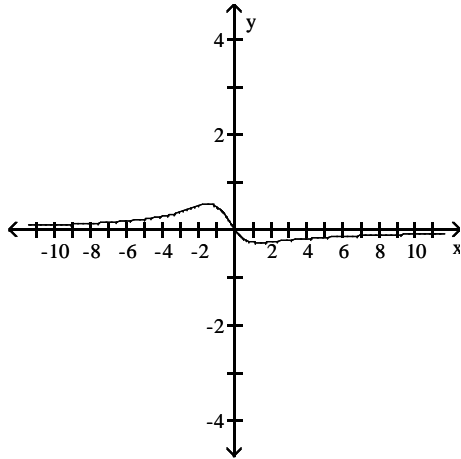

D) asymptote: $y = 1$

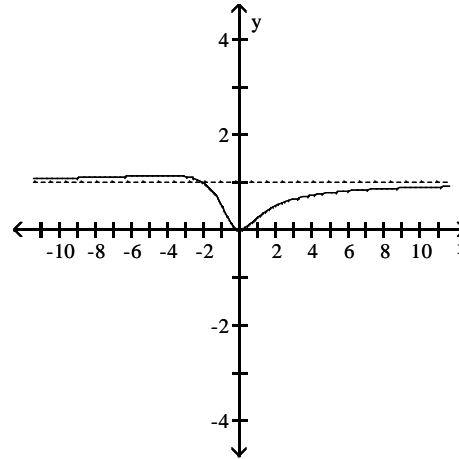

315) $y = \frac{x^2 + 3}{x^3}$

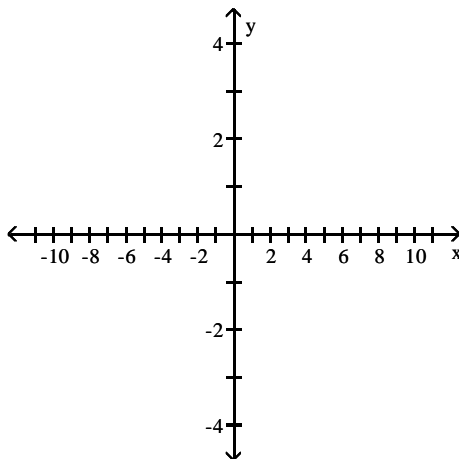

315) _____

A) asymptotes: $x = 0, y = 0$

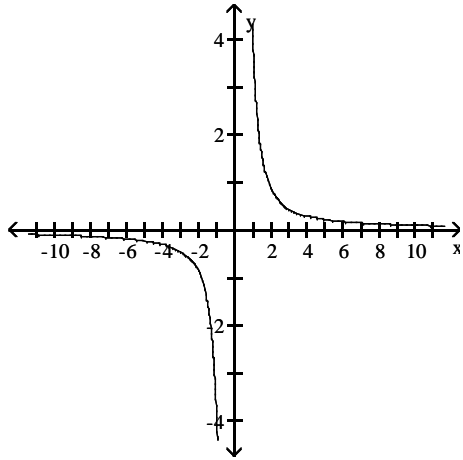

B) asymptotes: $x = 0, y = 0$

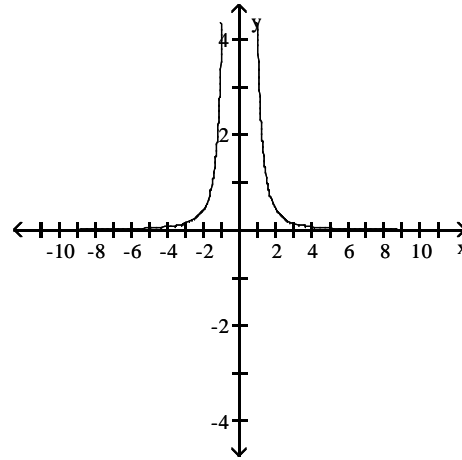

C) asymptotes: $x = 0, y = 0$

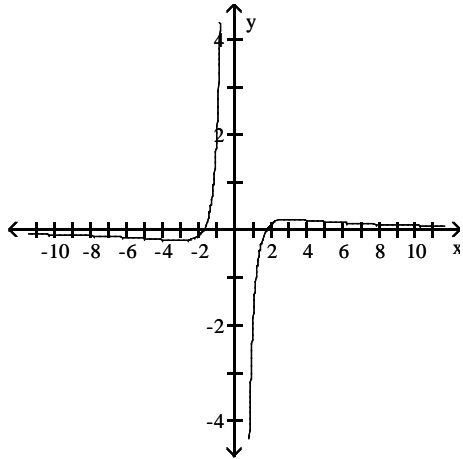

D) asymptote: $y = 0$

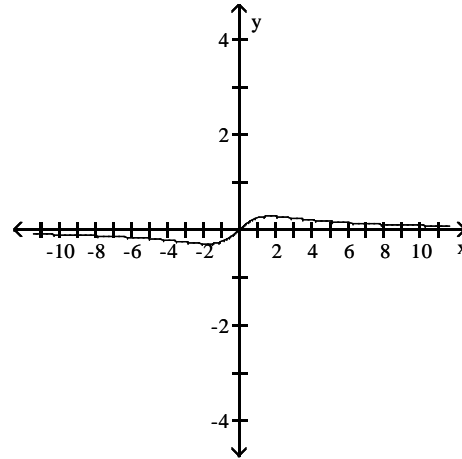

316) $y = \frac{1}{x+1}$

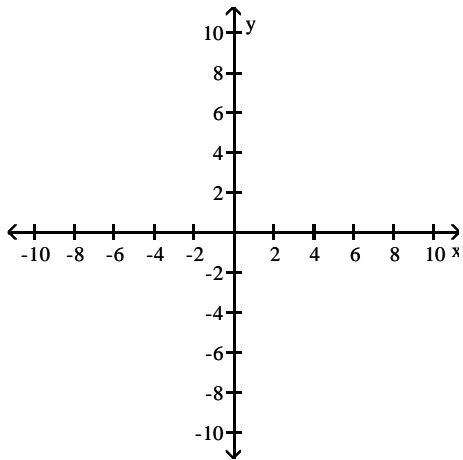

316) _____

A) asymptotes: $x = -1, y = 0$

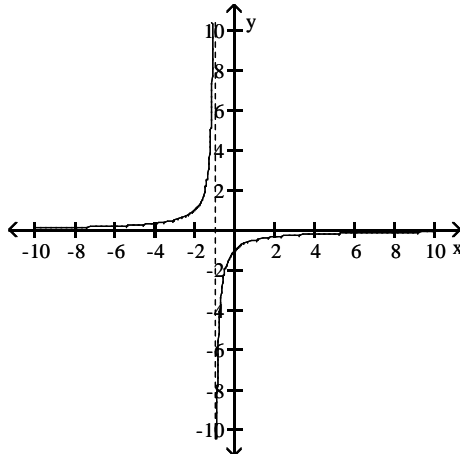

B) asymptotes: $x = 1, y = 0$

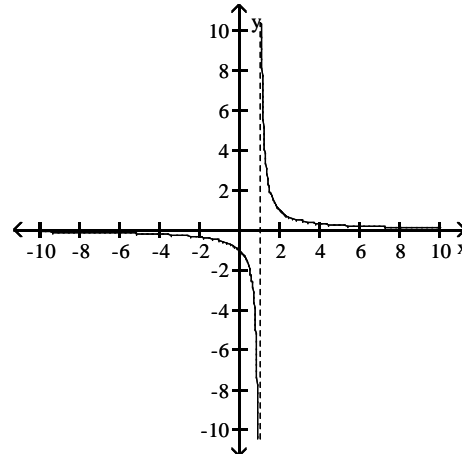

C) asymptotes: $x = 1, y = 0$

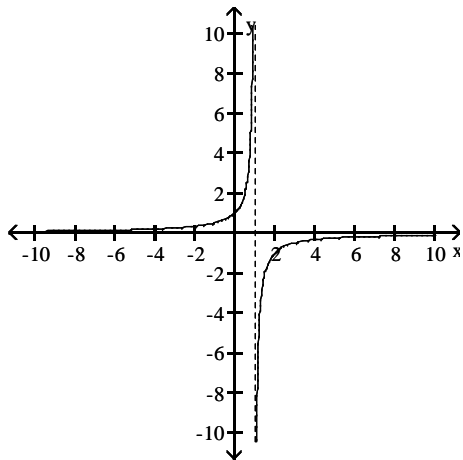

D) asymptotes: $x = -1, y = 0$

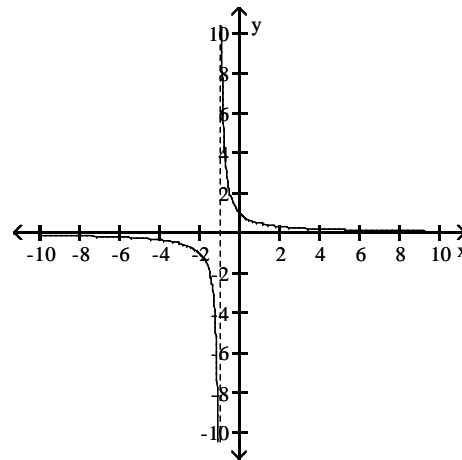

317) $y = \frac{x - 1}{x + 1}$

317) _____

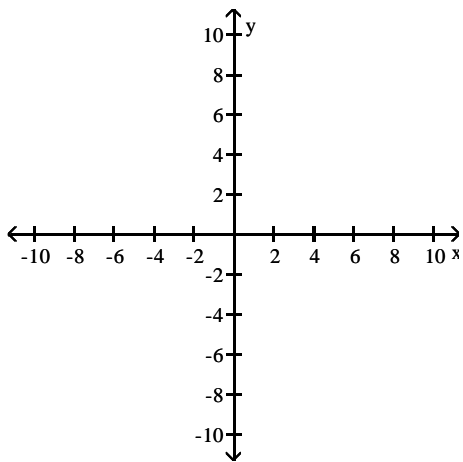

A) asymptotes: $x = 1, y = -1$

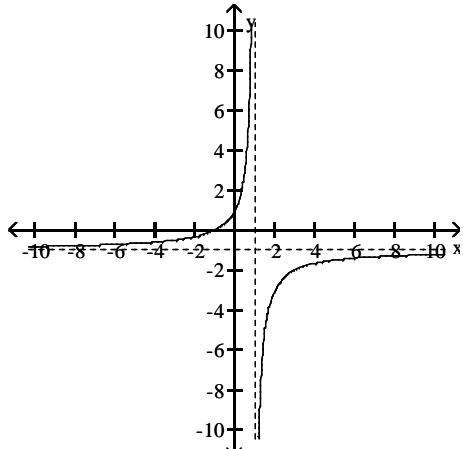

B) asymptotes: $x = 1, y = 1$

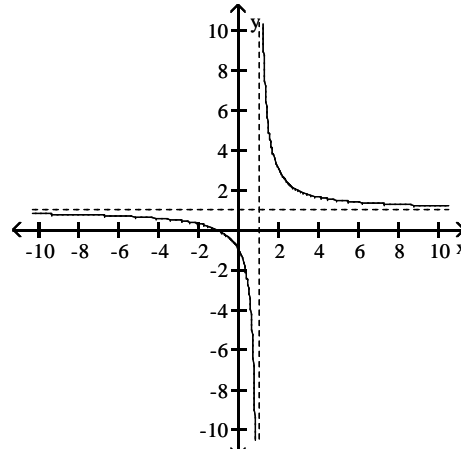

C) asymptotes: $x = -1, y = 1$

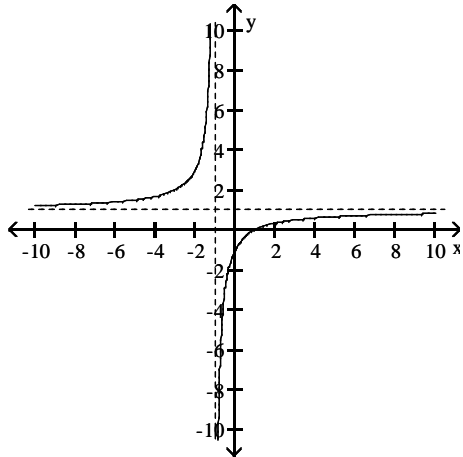

D) asymptotes: $x = -1, y = -1$

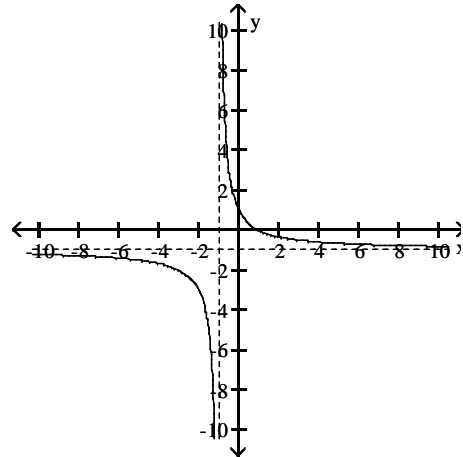

318) $y = \frac{1}{(x+2)^2}$

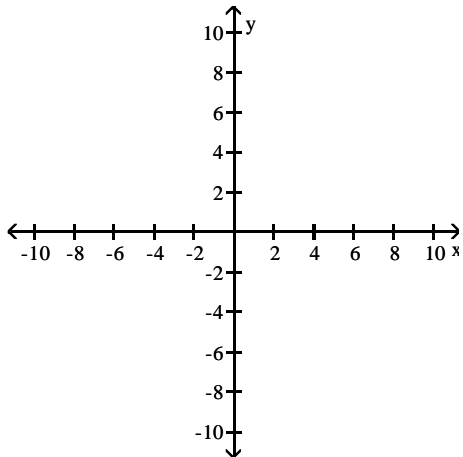

318) _____

A) asymptotes: $x = 2, y = 0$

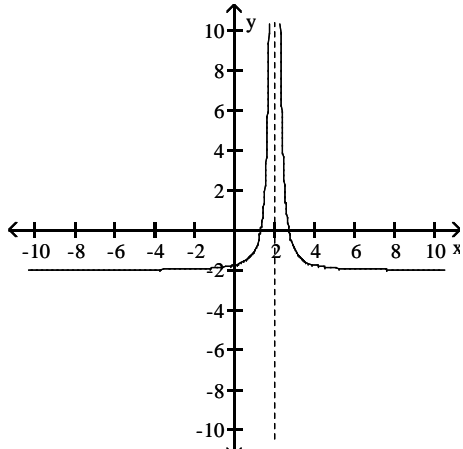

B) asymptotes: $x = -2, y = 0$

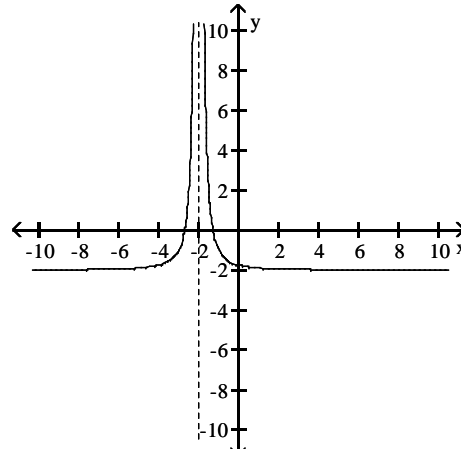

C) asymptotes: $x = 2, y = 0$

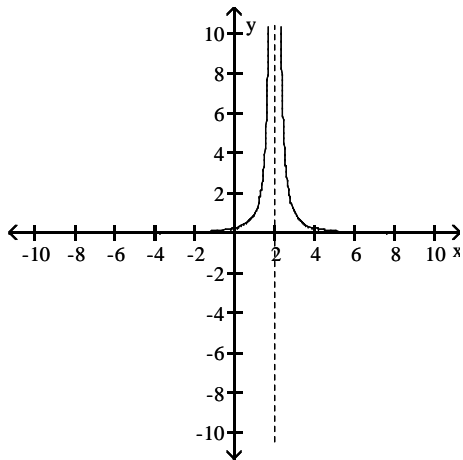

D) asymptotes: $x = -2, y = 0$

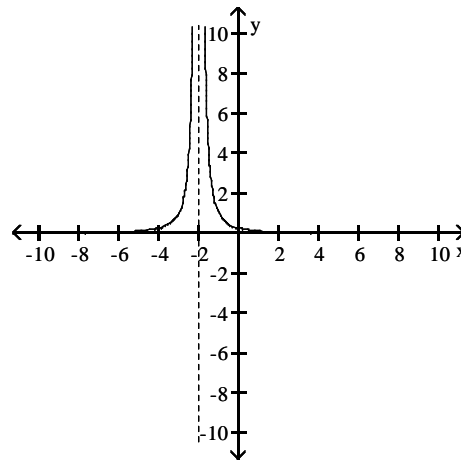

319) $y = \frac{2x^2}{4 - x^2}$

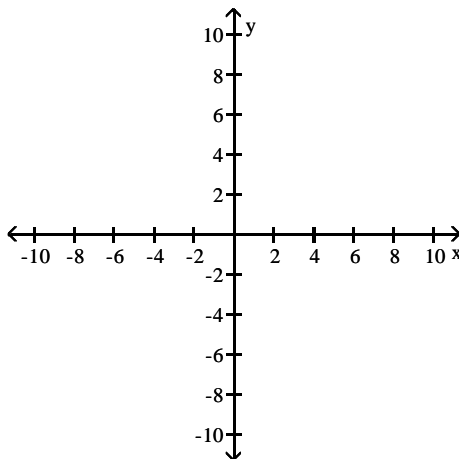

319) _____

A) asymptotes: $x = -2, x = 2, y = -2$

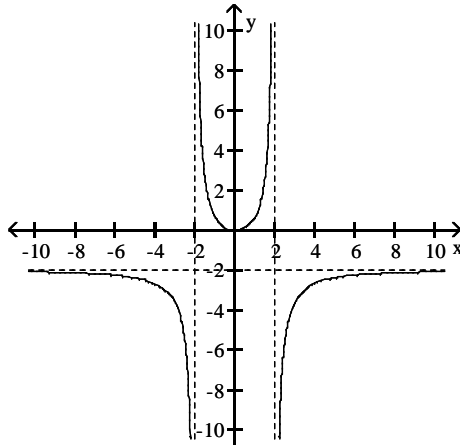

B) asymptotes: $x = -2, x = 2, y = 0$

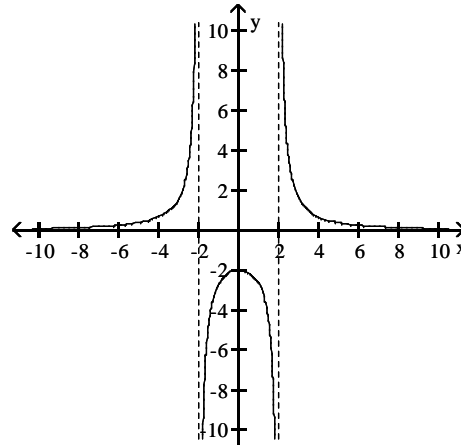

C) asymptotes: $x = -2, x = 2, y = 2$

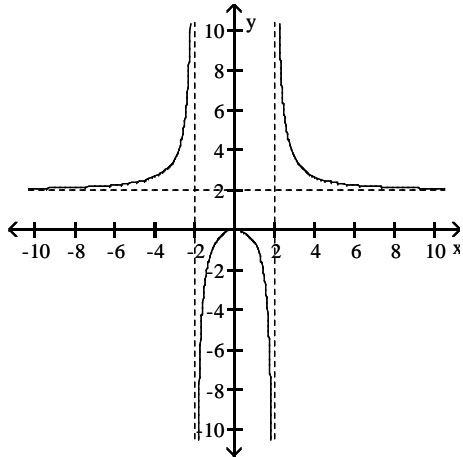

D) asymptotes: $x = -2, x = 2, y = 0$

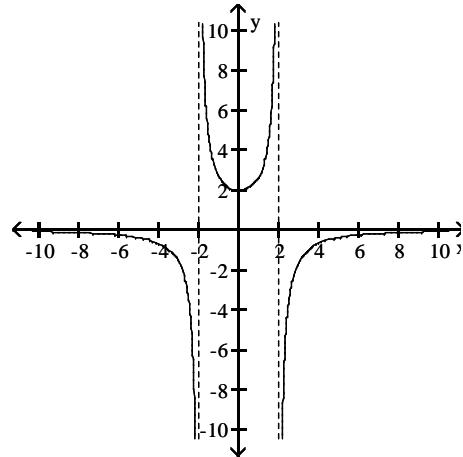

320) $y = \frac{2 - x^2}{2x + 4}$

320) _____

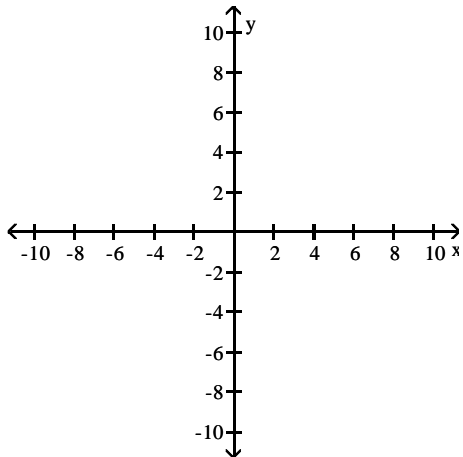

A) asymptotes: $x = -2$, $y = -\frac{1}{2}x + 1$

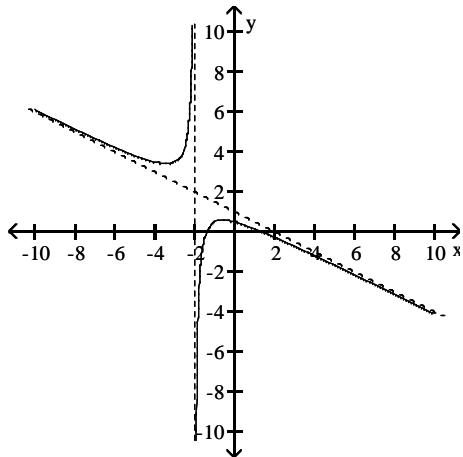

B) asymptotes: $x = -4$, $y = -\frac{1}{8}x + \frac{1}{2}$

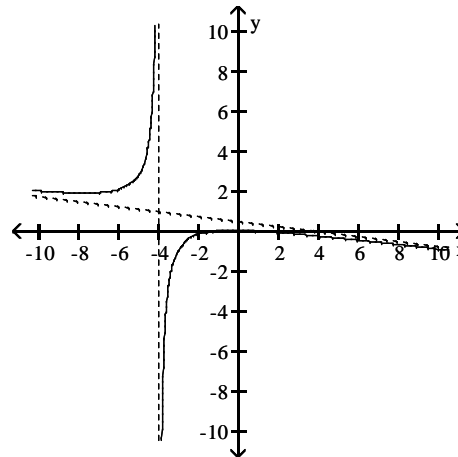

C) asymptotes: $x = -2$, $y = -x + 2$

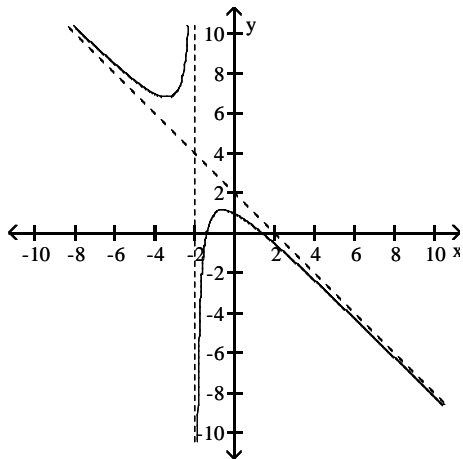

D) asymptotes: $x = -2$, $y = -\frac{1}{4}x + \frac{1}{2}$

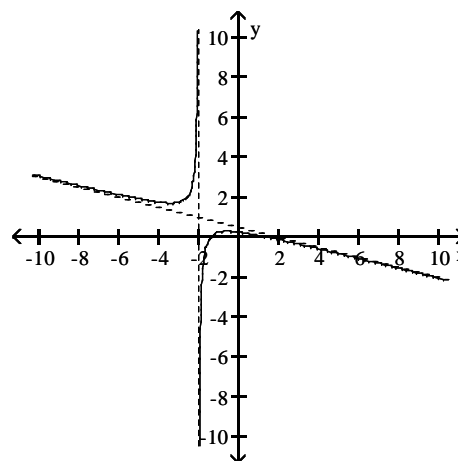

321) $y = \frac{2 - 2x - x^2}{x}$

321) _____

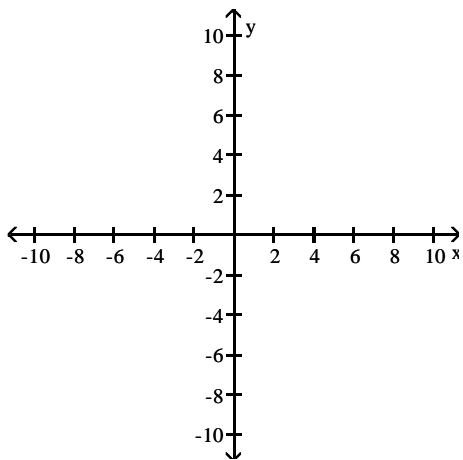

A) asymptotes: $x = 0, y = -x - 2$

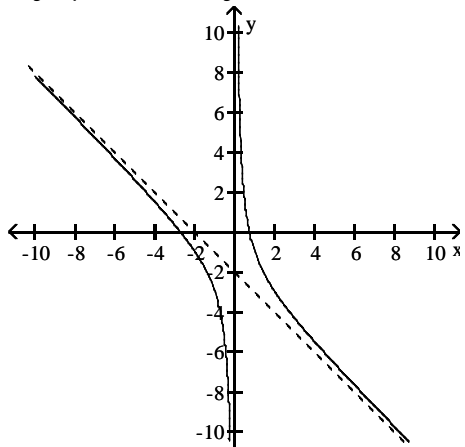

B) asymptotes: $x = 0, y = -x + 2$

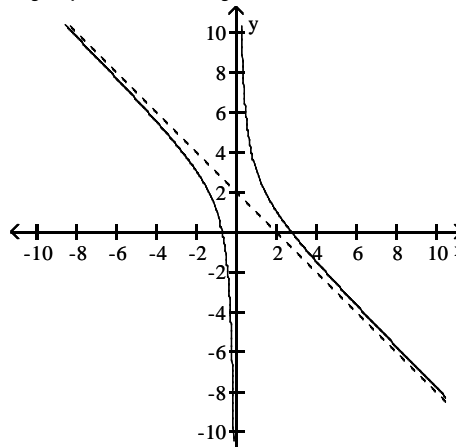

C) asymptotes: $x = 0, y = -x$

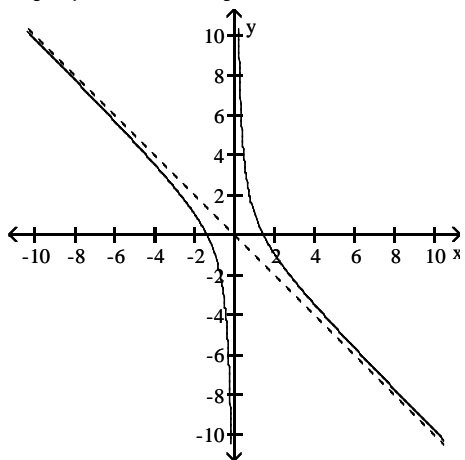

D) asymptotes: $x = 0, y = -x - 4$

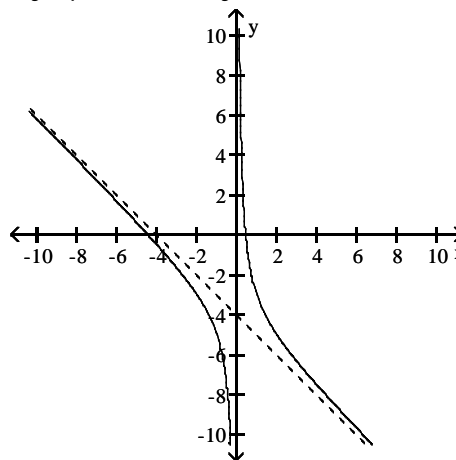

SHORT ANSWER. Write the word or phrase that best completes each statement or answers the question.

Sketch the graph of a function $y = f(x)$ that satisfies the given conditions.

322) $f(0) = 0, f(1) = 6, f(-1) = -6, \lim_{x \rightarrow -\infty} f(x) = -5, \lim_{x \rightarrow \infty} f(x) = 5.$

322) _____

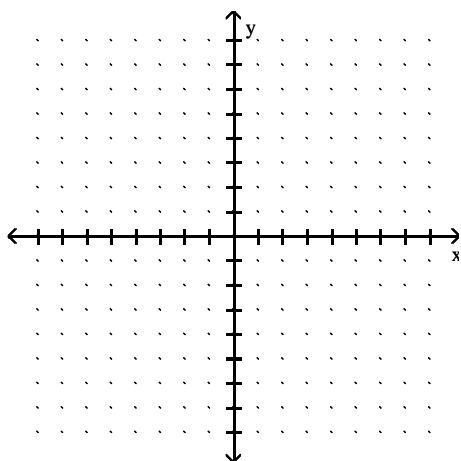

323) $f(0) = 0, f(1) = 4, f(-1) = 4, \lim_{x \rightarrow \pm\infty} f(x) = -4.$

323) _____

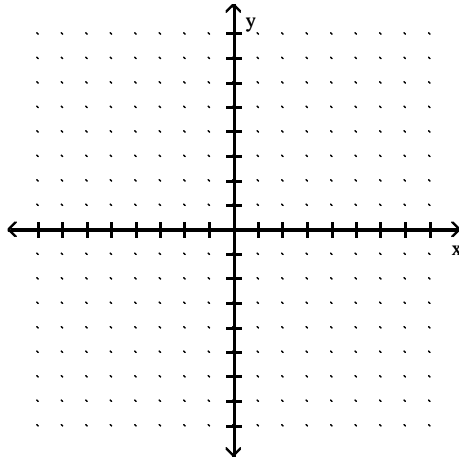

324) $f(0) = 5, f(1) = -5, f(-1) = -5, \lim_{x \rightarrow \pm\infty} f(x) = 0.$

324) _____

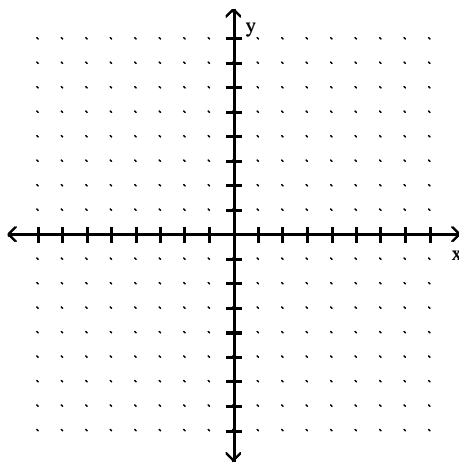

325) $f(0) = 0, \lim_{x \rightarrow \pm\infty} f(x) = 0, \lim_{x \rightarrow 2^-} f(x) = -\infty, \lim_{x \rightarrow -2^+} f(x) = -\infty, \lim_{x \rightarrow 2^+} f(x) = \infty, \lim_{x \rightarrow -2^-} f(x) = \infty.$

325) _____

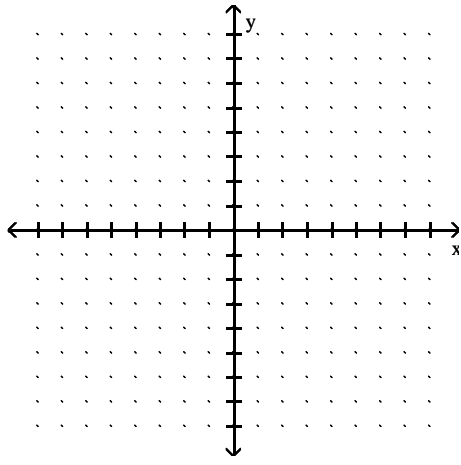

Find a function that satisfies the given conditions and sketch its graph.

326) $\lim_{x \rightarrow \pm\infty} f(x) = 0$, $\lim_{x \rightarrow 4^-} f(x) = \infty$, $\lim_{x \rightarrow 4^+} f(x) = \infty$.

326) _____

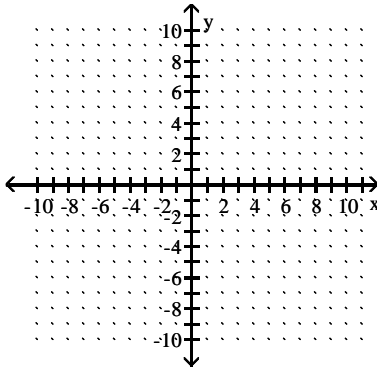

327) $\lim_{x \rightarrow \pm\infty} f(x) = 0$, $\lim_{x \rightarrow -2^-} f(x) = \infty$, $\lim_{x \rightarrow -2^+} f(x) = \infty$.

327) _____

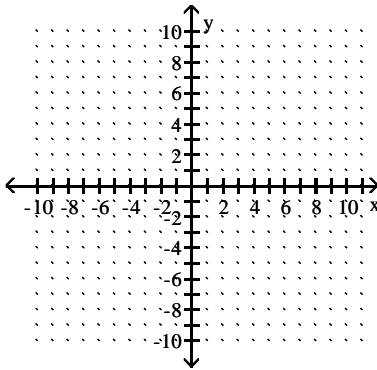

328) $\lim_{x \rightarrow -\infty} g(x) = -4$, $\lim_{x \rightarrow \infty} g(x) = 4$, $\lim_{x \rightarrow 0^+} g(x) = 4$, $\lim_{x \rightarrow 0^-} g(x) = -4$.

328) _____

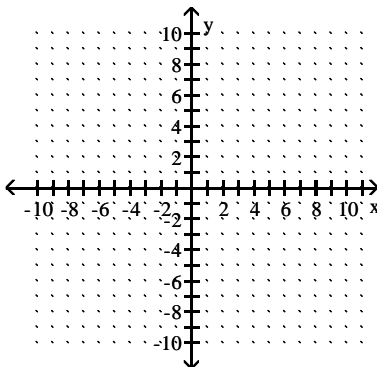

329) $\lim_{x \rightarrow \infty} f(x) = 0, \lim_{x \rightarrow 0^+} f(x) = \infty.$

329) _____

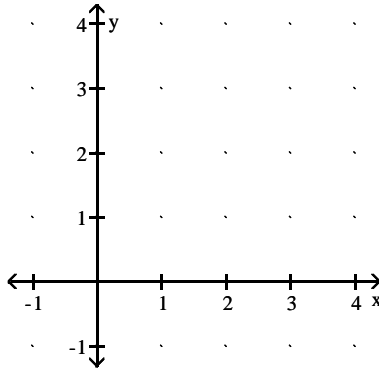

330) $\lim_{x \rightarrow -\infty} f(x) = 1, \lim_{x \rightarrow 0^+} f(x) = -1, \lim_{x \rightarrow \infty} f(x) = -1, \lim_{x \rightarrow 0^-} f(x) = 1$

330) _____

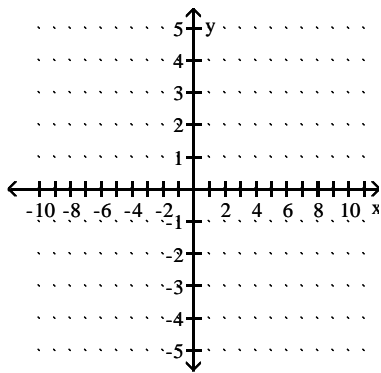

MULTIPLE CHOICE. Choose the one alternative that best completes the statement or answers the question.

Find the limit.

331) $\lim_{x \rightarrow \infty} (4x - \sqrt{16x^2 - 3x + 3})$

331) _____

- A) -12 B) $\frac{3}{8}$ C) $-\infty$ D) 0

332) $\lim_{x \rightarrow \infty} \sqrt{x^2 + 12x} - x$

332) _____

- A) 12 B) 0 C) 6 D) ∞

333) $\lim_{x \rightarrow \infty} (\sqrt{2x^2 + 7} - \sqrt{2x^2 - 3})$

333) _____

- A) $\frac{1}{2\sqrt{2}}$ B) $\sqrt{2}$ C) ∞ D) 0

334) $\lim_{x \rightarrow \infty} \sqrt{x^2 + 7x} - \sqrt{x^2 - 6x}$

334) _____

- A) $\frac{13}{2}$ B) does not exist C) $\frac{1}{2}$ D) 13

Provide an appropriate response.

335) Which of the following statements defines $\lim_{x \rightarrow x_0} f(x) = \infty$? 335) _____

- I. For every positive real number B there exists a corresponding $\delta > 0$ such that $f(x) > B$ whenever $x_0 - \delta < x < x_0 + \delta$.
 - II. For every positive real number B there exists a corresponding $\delta > 0$ such that $f(x) > B$ whenever $x_0 < x < x_0 + \delta$.
 - III. For every positive real number B there exists a corresponding $\delta > 0$ such that $f(x) > B$ whenever $x_0 - \delta < x < x_0$.
- A) II B) III C) I D) None

336) Which of the following statements defines $\lim_{x \rightarrow (x_0)^-} f(x) = \infty$? 336) _____

- I. For every positive real number B there exists a corresponding $\delta > 0$ such that $f(x) > B$ whenever $x_0 - \delta < x < x_0 + \delta$.
 - II. For every positive real number B there exists a corresponding $\delta > 0$ such that $f(x) > B$ whenever $x_0 < x < x_0 + \delta$.
 - III. For every positive real number B there exists a corresponding $\delta > 0$ such that $f(x) > B$ whenever $x_0 - \delta < x < x_0$.
- A) III B) I C) II D) None

337) Which of the following statements defines $\lim_{x \rightarrow (x_0)^+} f(x) = \infty$? 337) _____

- I. For every positive real number B there exists a corresponding $\delta > 0$ such that $f(x) > B$ whenever $x_0 - \delta < x < x_0 + \delta$.
 - II. For every positive real number B there exists a corresponding $\delta > 0$ such that $f(x) > B$ whenever $x_0 < x < x_0 + \delta$.
 - III. For every positive real number B there exists a corresponding $\delta > 0$ such that $f(x) > B$ whenever $x_0 - \delta < x < x_0$.
- A) III B) I C) II D) None

338) Which of the following statements defines $\lim_{x \rightarrow x_0} f(x) = -\infty$? 338) _____

- I. For every negative real number B there exists a corresponding $\delta > 0$ such that $f(x) < B$ whenever $x_0 - \delta < x < x_0 + \delta$.
 - II. For every negative real number B there exists a corresponding $\delta > 0$ such that $f(x) < B$ whenever $x_0 < x < x_0 + \delta$.
 - III. For every negative real number B there exists a corresponding $\delta > 0$ such that $f(x) < B$ whenever $x_0 - \delta < x < x_0$.
- A) III B) II C) I D) None

- 339) Which of the following statements defines $\lim_{x \rightarrow (x_0)^+} f(x) = -\infty$? 339) _____
- I. For every negative real number B there exists a corresponding $\delta > 0$ such that $f(x) < B$ whenever $x_0 - \delta < x < x_0 + \delta$.
- II. For every negative real number B there exists a corresponding $\delta > 0$ such that $f(x) < B$ whenever $x_0 < x < x_0 + \delta$.
- III. For every negative real number B there exists a corresponding $\delta > 0$ such that $f(x) < B$ whenever $x_0 - \delta < x < x_0$.
- A) I B) III C) II D) None

- 340) Which of the following statements defines $\lim_{x \rightarrow (x_0)^-} f(x) = -\infty$? 340) _____
- I. For every negative real number B there exists a corresponding $\delta > 0$ such that $f(x) < B$ whenever $x_0 - \delta < x < x_0 + \delta$.
- II. For every negative real number B there exists a corresponding $\delta > 0$ such that $f(x) < B$ whenever $x_0 < x < x_0 + \delta$.
- III. For every negative real number B there exists a corresponding $\delta > 0$ such that $f(x) < B$ whenever $x_0 - \delta < x < x_0$.
- A) II B) I C) III D) None

- 341) Which of the following statements defines $\lim_{x \rightarrow -\infty} f(x) = \infty$? 341) _____
- I. For every positive real number B there exists a corresponding positive real number N such that $f(x) > B$ whenever $x > N$.
- II. For every positive real number B there exists a corresponding negative real number N such that $f(x) > B$ whenever $x < N$.
- III. For every negative real number B there exists a corresponding negative real number N such that $f(x) < B$ whenever $x < N$.
- IV. For every negative real number B there exists a corresponding positive real number N such that $f(x) < B$ whenever $x > N$.
- A) I B) IV C) III D) II

SHORT ANSWER. Write the word or phrase that best completes each statement or answers the question.

- 342) Use the formal definitions of limits to prove $\lim_{x \rightarrow 0} \frac{7}{|x|} = \infty$ 342) _____

- 343) Use the formal definitions of limits to prove $\lim_{x \rightarrow 0^+} \frac{8}{x} = \infty$ 343) _____

Answer Key

Testname: UNTITLED2

- 1) D
- 2) D
- 3) A
- 4) D
- 5) C
- 6) C
- 7) A
- 8) C
- 9) B
- 10) C
- 11) D
- 12) D
- 13) B
- 14) A
- 15) D
- 16) B
- 17) C
- 18) D
- 19) D
- 20) D
- 21) A
- 22) D
- 23) A
- 24) B
- 25) C
- 26) B
- 27) C
- 28) D
- 29) B
- 30) C
- 31) B
- 32) B
- 33) B
- 34) B
- 35) D
- 36) B
- 37) B
- 38) C
- 39) D
- 40) D
- 41) A
- 42) A
- 43) A
- 44) D
- 45) B
- 46) A
- 47) C
- 48) C
- 49) A
- 50) C

Answer Key

Testname: UNTITLED2

- 51) C
- 52) B
- 53) B
- 54) D
- 55) A
- 56) D
- 57) B
- 58) A
- 59) D
- 60) C
- 61) A
- 62) C
- 63) C
- 64) C
- 65) D
- 66) D
- 67) B
- 68) B
- 69) A
- 70) A
- 71) B
- 72) D
- 73) B
- 74) D
- 75) C
- 76) C
- 77) A
- 78) B
- 79) D
- 80) A
- 81) A
- 82) C
- 83) D
- 84) C
- 85) A
- 86) C
- 87) C
- 88) C
- 89) A
- 90) B
- 91) D
- 92) D
- 93) C
- 94) C
- 95) A
- 96) B
- 97) C
- 98) D
- 99) D
- 100) D

Answer Key

Testname: UNTITLED2

- 101) C
- 102) C
- 103) B
- 104) D
- 105) C
- 106) C
- 107) B
- 108) A
- 109) B
- 110) A
- 111) C
- 112) C
- 113) C
- 114) D
- 115) B
- 116) B
- 117) B
- 118) D
- 119) D
- 120) B

121) Answers may vary. One possibility: $\lim_{x \rightarrow 0} 1 - \frac{x^2}{6} = \lim_{x \rightarrow 0} 1 = 1$. According to the squeeze theorem, the function

$\frac{x \sin(x)}{2 - 2 \cos(x)}$, which is squeezed between $1 - \frac{x^2}{6}$ and 1, must also approach 1 as x approaches 0. Thus,

$$\lim_{x \rightarrow 0} \frac{x \sin(x)}{2 - 2 \cos(x)} = 1.$$

- 122) B
- 123) B
- 124) C
- 125) B
- 126) C
- 127) C
- 128) D
- 129) A
- 130) D
- 131) B
- 132) D
- 133) A
- 134) A
- 135) B
- 136) B
- 137) B
- 138) B
- 139) B
- 140) B
- 141) A
- 142) A
- 143) D

Answer Key

Testname: UNTITLED2

144) B

145) C

146) C

147) A

148) A

149) D

150) A

151) A

152) B

153)

Let $\varepsilon > 0$ be given. Choose $\delta = \varepsilon/2$. Then $0 < |x - 1| < \delta$ implies that

$$\begin{aligned} |(2x - 3) + 1| &= |2x - 2| \\ &= |2(x - 1)| \\ &= 2|x - 1| < 2\delta = \varepsilon \end{aligned}$$

Thus, $0 < |x - 1| < \delta$ implies that $|(2x - 3) + 1| < \varepsilon$

154) Let $\varepsilon > 0$ be given. Choose $\delta = \varepsilon$. Then $0 < |x - 3| < \delta$ implies that

$$\begin{aligned} \left| \frac{x^2 - 9}{x - 3} - 6 \right| &= \left| \frac{(x - 3)(x + 3)}{x - 3} - 6 \right| \\ &= |(x + 3) - 6| \quad \text{for } x \neq 3 \\ &= |x - 3| < \delta = \varepsilon \end{aligned}$$

Thus, $0 < |x - 3| < \delta$ implies that $\left| \frac{x^2 - 9}{x - 3} - 6 \right| < \varepsilon$

155) Let $\varepsilon > 0$ be given. Choose $\delta = \varepsilon/3$. Then $0 < |x - 2| < \delta$ implies that

$$\begin{aligned} \left| \frac{3x^2 - 5x - 2}{x - 2} - 7 \right| &= \left| \frac{(x - 2)(3x + 1)}{x - 2} - 7 \right| \\ &= |(3x + 1) - 7| \quad \text{for } x \neq 2 \\ &= |3x - 6| \\ &= |3(x - 2)| \\ &= 3|x - 2| < 3\delta = \varepsilon \end{aligned}$$

Thus, $0 < |x - 2| < \delta$ implies that $\left| \frac{3x^2 - 5x - 2}{x - 2} - 7 \right| < \varepsilon$

156) Let $\varepsilon > 0$ be given. Choose $\delta = \min\{7/2, 49\varepsilon/2\}$. Then $0 < |x - 7| < \delta$ implies that

$$\begin{aligned} \left| \frac{1}{x} - \frac{1}{7} \right| &= \left| \frac{7 - x}{7x} \right| \\ &= \frac{1}{|x|} \cdot \frac{1}{7} \cdot |x - 7| \\ &< \frac{1}{7/2} \cdot \frac{1}{7} \cdot \frac{49\varepsilon}{2} = \varepsilon \end{aligned}$$

Thus, $0 < |x - 7| < \delta$ implies that $\left| \frac{1}{x} - \frac{1}{7} \right| < \varepsilon$

157) B

158) A

159) D

160) B

161) A

162) B

163) A

Answer Key

Testname: UNTITLED2

- 164) D
- 165) B
- 166) C
- 167) A
- 168) B
- 169) B
- 170) B
- 171) C
- 172) D
- 173) D
- 174) C
- 175) D
- 176) D
- 177) C
- 178) C
- 179) C
- 180) A
- 181) B
- 182) D
- 183) C
- 184) B
- 185) A
- 186) B
- 187) D
- 188) A
- 189) C
- 190) C
- 191) A
- 192) B
- 193) C
- 194) B
- 195) C
- 196) A
- 197) B
- 198) D
- 199) A
- 200) A
- 201) D
- 202) C
- 203) A
- 204) C
- 205) D
- 206) C
- 207) A
- 208) C
- 209) B
- 210) A
- 211) D
- 212) D
- 213) A

Answer Key

Testname: UNTITLED2

- 214) A
215) B
216) A
217) A
218) B
219) A
220) A
221) A
222) A
223) B
224) B
225) B
226) D
227) A
228) D
229) B
230) D
231) B
232) B
233) B
234) D
235) A
236) A
237) A
238) A
239) B
240) D
241) A
242) D
243) D
244) A
245) C
246) B
247) C
248) B
249) A
250) B
251) A
252) A
253) C
254) Let $f(x) = 5x^3 - 8x^2 + 4x - 3$ and let $y_0 = 0$. $f(1) = -2$ and $f(2) = 13$. Since f is continuous on $[1, 2]$ and since $y_0 = 0$ is between $f(1)$ and $f(2)$, by the Intermediate Value Theorem, there exists a c in the interval $(1, 2)$ with the property that $f(c) = 0$. Such a c is a solution to the equation $5x^3 - 8x^2 + 4x - 3 = 0$.
255) Let $f(x) = 10x^4 + 6x^3 - 9x - 6$ and let $y_0 = 0$. $f(-1) = 7$ and $f(0) = -6$. Since f is continuous on $[-1, 0]$ and since $y_0 = 0$ is between $f(-1)$ and $f(0)$, by the Intermediate Value Theorem, there exists a c in the interval $(-1, 0)$ with the property that $f(c) = 0$. Such a c is a solution to the equation $10x^4 + 6x^3 - 9x - 6 = 0$.

Answer Key

Testname: UNTITLED2

256) Let $f(x) = x(x - 3)^2$ and let $y_0 = 3$. $f(2) = 2$ and $f(4) = 4$. Since f is continuous on $[2, 4]$ and since $y_0 = 3$ is between $f(2)$ and $f(4)$, by the Intermediate Value Theorem, there exists a c in the interval $(2, 4)$ with the property that $f(c) = 3$. Such a c is a solution to the equation $x(x - 3)^2 = 3$.

257) Let $f(x) = \frac{\sin x}{x}$ and let $y_0 = \frac{1}{3}$. $f\left(\frac{\pi}{2}\right) \approx 0.6366$ and $f(\pi) = 0$. Since f is continuous on $\left[\frac{\pi}{2}, \pi\right]$ and since $y_0 = \frac{1}{3}$ is between $f\left(\frac{\pi}{2}\right)$ and $f(\pi)$, by the Intermediate Value Theorem, there exists a c in the interval $\left(\frac{\pi}{2}, \pi\right)$, with the property that $f(c) = \frac{1}{3}$. Such a c is a solution to the equation $3 \sin x = x$.

258) D

259) C

260) The Intermediate Value Theorem implies that there is at least one solution to $f(x) = 0$ on the interval $[1, 2]$.

Possible graph:

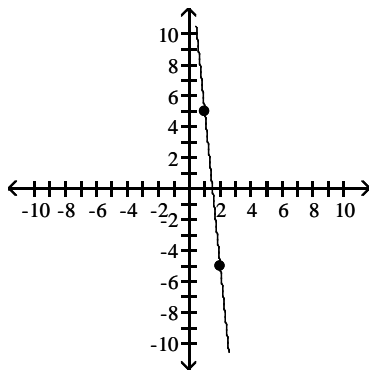

261) The roots of $f(x)$ are the solutions to the equation $f(x) = 0$. Statement (b) is asking for the solution to the equation $2x^3 = 1x + 3$. Statement (d) is asking for the solution to the equation $2x^3 - 1x = 3$. These three equations are equivalent to the equations in statements (c) and (e). As five equations are equivalent, their solutions are the same.

262) Notice that $f(0) = 5$ and $f(1) = 2$. As f is continuous on $[0, 1]$, the Intermediate Value Theorem implies that there is a number c such that $f(c) = \pi$.

263) Yes, if $f(x) = 1$ and $g(x) = x - 1$, then $h(x) = \frac{1}{x - 1}$ is discontinuous at $x = 1$.

264) Let $f(x) = \frac{\sin(x - 10)}{(x - 10)}$ be defined for all $x \neq 10$. The function f is continuous for all $x \neq 10$. The function is not defined at $x = 10$ because division by zero is undefined; hence f is not continuous at $x = 10$. This discontinuity is removable because $\lim_{x \rightarrow 10} \frac{\sin(x - 10)}{x - 10} = 1$. (We can extend the function to $x = 10$ by defining its value to be 1.)

265) Let $f(x) = \frac{1}{(x - 4)^2}$, for all $x \neq 4$. The function f is continuous for all $x \neq 4$, and $\lim_{x \rightarrow 4} \frac{1}{(x - 4)^2} = \infty$. As f is unbounded as x approaches 4, f is discontinuous at $x = 4$, and, moreover, this discontinuity is nonremovable.

266) D

267) D

268) D

269) C

270) D

271) A

272) A

Answer Key

Testname: UNTITLED2

- 273) D
- 274) C
- 275) A
- 276) A
- 277) C
- 278) A
- 279) A
- 280) C
- 281) A
- 282) D
- 283) C
- 284) C
- 285) B
- 286) A
- 287) B
- 288) D
- 289) C
- 290) D
- 291) D
- 292) C
- 293) A
- 294) A
- 295) D
- 296) C
- 297) A
- 298) D
- 299) D
- 300) D
- 301) A
- 302) B
- 303) C
- 304) D
- 305) C
- 306) D
- 307) D
- 308) C
- 309) C
- 310) C
- 311) D
- 312) C
- 313) D
- 314) B
- 315) A
- 316) D
- 317) C
- 318) D
- 319) A
- 320) A
- 321) A

Answer Key

Testname: UNTITLED2

322) Answers may vary. One possible answer:

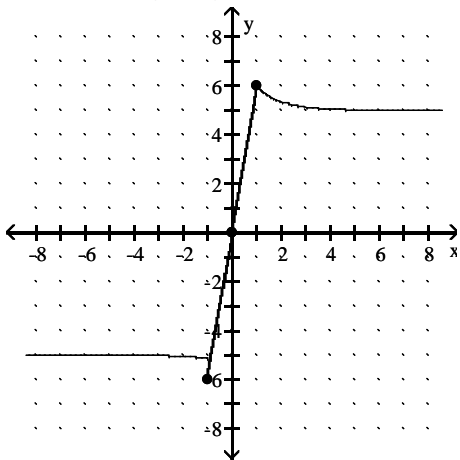

323) Answers may vary. One possible answer:

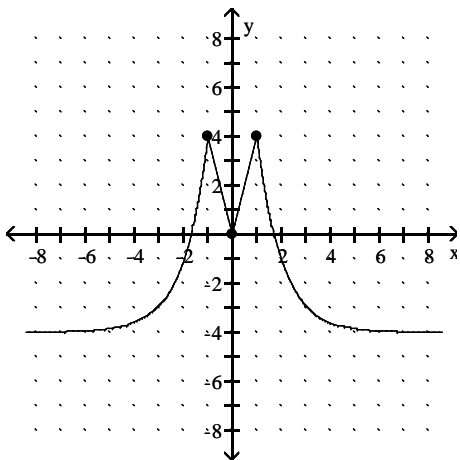

324) Answers may vary. One possible answer:

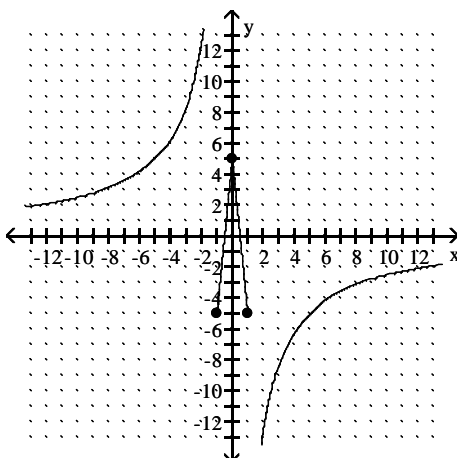

Answer Key

Testname: UNTITLED2

325) Answers may vary. One possible answer:

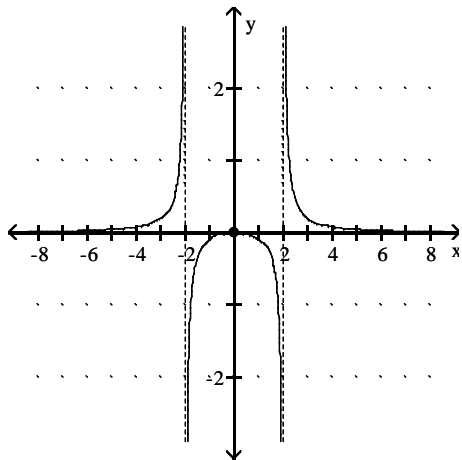

326) (Answers may vary.) Possible answer: $f(x) = \frac{1}{|x - 4|}$.

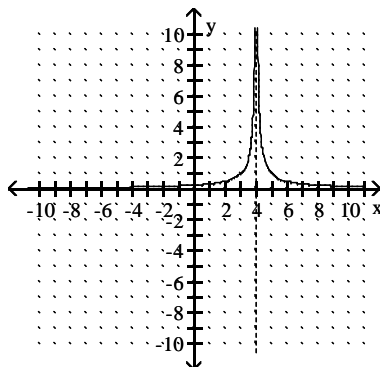

327) (Answers may vary.) Possible answer: $f(x) = \frac{1}{|x + 2|}$.

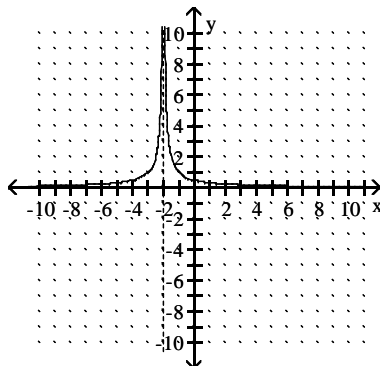

Answer Key

Testname: UNTITLED2

328) (Answers may vary.) Possible answer: $f(x) = \begin{cases} 4, & x > 0 \\ -4, & x < 0 \end{cases}$

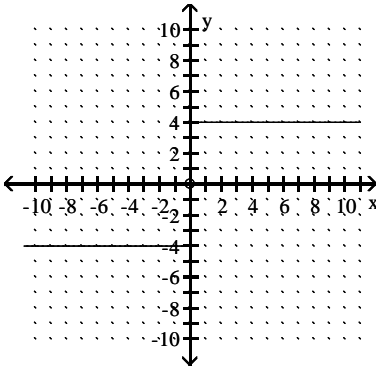

329) (Answers may vary.) Possible answer: $f(x) = \frac{1}{\sqrt{x}}$.

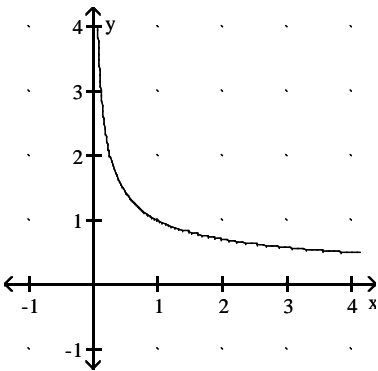

330) (Answers may vary.) Possible answer: $f(x) = \begin{cases} 1, & x < 0 \\ -1, & x > 0 \end{cases}$

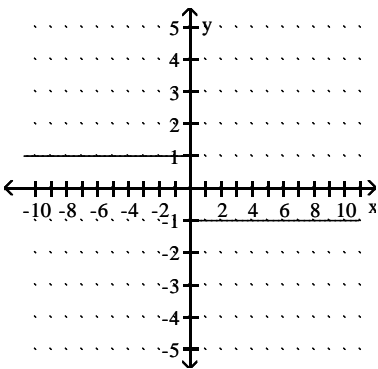

- 331) B
- 332) C
- 333) D
- 334) A
- 335) C
- 336) A
- 337) C
- 338) C
- 339) C
- 340) C
- 341) D

Answer Key

Testname: UNTITLED2

342) Given $B > 0$, we want to find $\delta > 0$ such that $0 < |x - 0| < \delta$ implies $\frac{7}{|x|} > B$.

Now, $\frac{7}{|x|} > B$ if and only if $|x| < \frac{7}{B}$.

Thus, choosing $\delta = 7/B$ (or any smaller positive number), we see that

$|x| < \delta$ implies $\frac{7}{|x|} > \frac{7}{|\delta|} \geq B$.

Therefore, by definition $\lim_{x \rightarrow 0} \frac{7}{|x|} = \infty$

343) Given $B > 0$, we want to find $\delta > 0$ such that $x_0 < x < x_0 + \delta$ implies $\frac{8}{x} > B$.

Now, $\frac{8}{x} > B$ if and only if $x < \frac{8}{B}$.

We know $x_0 = 0$. Thus, choosing $\delta = 8/B$ (or any smaller positive number), we see that

$x < \delta$ implies $\frac{8}{x} > \frac{8}{\delta} \geq B$.

Therefore, by definition $\lim_{x \rightarrow 0^+} \frac{8}{x} = \infty$