

Ch. 2 Functions and Their Graphs

2.1 Functions

1 Determine Whether a Relation Represents a Function

MULTIPLE CHOICE. Choose the one alternative that best completes the statement or answers the question.

Determine whether the relation represents a function. If it is a function, state the domain and range.

1)

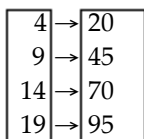

A) function

domain: {20, 45, 70, 95}
range: {4, 9, 14, 19}

B) function

domain: {4, 9, 14, 19}
range: {20, 45, 70, 95}

C) not a function

2)

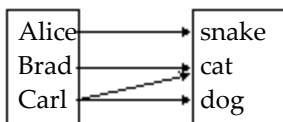

A) function

domain: {Alice, Brad, Carl}
range: {snake, cat, dog}

B) function

domain: {snake, cat, dog}
range: {Alice, Brad, Carl}

C) not a function

3)

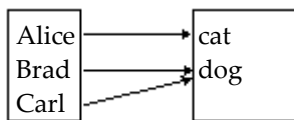

A) function

domain: {cat, dog}
range: {Alice, Brad, Carl}

B) function

domain: {Alice, Brad, Carl}
range: {cat, dog}

C) not a function

4) $\{(-1, -6), (2, 5), (5, -3), (6, -1)\}$

A) function

domain: $\{-6, 5, -3, -1\}$
range: $\{-1, 2, 5, 6\}$

B) function

domain: $\{-1, 2, 5, 6\}$
range: $\{-6, 5, -3, -1\}$

C) not a function

5) $\{(-1, -3), (-2, -2), (-2, 0), (2, 2), (14, 4)\}$

A) function

domain: $\{-1, 2, -2, 14\}$
range: $\{-3, -2, 0, 2, 4\}$

B) function

domain: $\{-3, -2, 0, 2, 4\}$
range: $\{-1, 2, -2, 14\}$

C) not a function

6) $\{(-2, -1), (-1, -4), (0, -5), (1, -4), (3, 4)\}$

A) function

domain: $\{-1, -4, -5, 4\}$
range: $\{-2, -1, 0, 1, 3\}$

B) function

domain: $\{-2, -1, 0, 1, 3\}$
range: $\{-1, -4, -5, 4\}$

C) not a function

7) $\{(2.11, 10.21), (2.111, -10.2), (\frac{3}{7}, 0), (0.43, -2)\}$

A) function

domain: $\{2.11, 2.111, \frac{3}{7}, 0.43\}$

range: $\{10.21, -10.2, 0, -2\}$

B) function

domain: $\{10.21, -10.2, 0, -2\}$

range: $\{2.11, 2.111, \frac{3}{7}, 0.43\}$

C) not a function

Determine whether the equation defines y as a function of x.

8) $y = x^4$

A) function

B) not a function

9) $y = \frac{1}{x}$

A) function

B) not a function

10) $y = |x|$

A) function

B) not a function

11) $y^2 = 4 - x^2$

A) function

B) not a function

12) $y = \pm\sqrt{1 - 8x}$

A) function

B) not a function

13) $x = y^2$

A) function

B) not a function

14) $y^2 + x = 3$

A) function

B) not a function

15) $y = 3x^2 - 7x + 8$

A) function

B) not a function

16) $y = \frac{4x - 1}{x + 1}$

A) function

B) not a function

17) $x^2 - 4y^2 = 1$

A) function

B) not a function

18) $x + 3y = 3$

A) function

B) not a function

19) $8x + x^2 - 59 = y$

A) function

B) not a function

2 Find the Value of a Function

MULTIPLE CHOICE. Choose the one alternative that best completes the statement or answers the question.

Find the value for the function.

1) Find $f(4)$ when $f(x) = x^2 + 5x - 1$.

A) 37

B) -5

C) -3

D) 35

2) Find $f(2)$ when $f(x) = \frac{x^2 - 6}{x + 1}$.

A) $\frac{4}{3}$

B) $-\frac{2}{3}$

C) -4

D) $\frac{10}{3}$

3) Find $f(-9)$ when $f(x) = |x| - 6$.

A) 15

B) 3

C) -15

D) -3

4) Find $f(8)$ when $f(x) = \sqrt{x^2 + 9x}$.

A) $\sqrt{73}$

B) $3\sqrt{10}$

C) $2\sqrt{34}$

D) $\sqrt{145}$

5) Find $f(-x)$ when $f(x) = -2x^2 + 5x - 4$.

A) $-2x^2 - 5x + 4$

B) $2x^2 - 5x - 4$

C) $2x^2 - 5x + 4$

D) $-2x^2 - 5x - 4$

6) Find $f(-x)$ when $f(x) = \frac{x}{x^2 + 4}$.

A) $\frac{-x}{x^2 - 4}$

B) $\frac{x}{-x^2 + 4}$

C) $\frac{-x}{x^2 + 4}$

D) $\frac{-x}{-x^2 + 4}$

7) Find $-f(x)$ when $f(x) = -3x^2 + 5x + 1$.

A) $-3x^2 - 5x - 1$

B) $3x^2 - 5x - 1$

C) $3x^2 - 5x + 1$

D) $-3x^2 - 5x + 1$

8) Find $-f(x)$ when $f(x) = |x| + 7$.

A) $|-x| - 7$

B) $-|x| - 7$

C) $-|x| + 7$

D) $|-x| + 7$

9) Find $f(x - 1)$ when $f(x) = 3x^2 - 3x + 3$.

A) $3x^2 - 9x + 9$

B) $3x^2 + 6x + 3$

C) $3x^2 - 9x + 3$

D) $-9x^2 + 3x + 9$

10) Find $f(x + 1)$ when $f(x) = \frac{x^2 - 8}{x + 4}$.

A) $\frac{x^2 + 2x + 9}{x + 5}$

B) $\frac{x^2 + 2x - 7}{x + 5}$

C) $\frac{x^2 - 7}{x + 5}$

D) $\frac{x^2 + 2x - 7}{x - 3}$

11) Find $f(2x)$ when $f(x) = 2x^2 - 2x - 3$.

A) $8x^2 - 4x - 3$

B) $4x^2 - 4x - 6$

C) $8x^2 - 4x - 6$

D) $4x^2 - 4x - 3$

12) Find $f(2x)$ when $f(x) = \sqrt{7x^2 - 3x}$.

A) $\sqrt{14x^2 - 12x}$

B) $2\sqrt{7x^2 - 3x}$

C) $\sqrt{28x^2 - 6x}$

D) $\sqrt{14x^2 - 6x}$

13) Find $f(x + h)$ when $f(x) = -2x^2 + 2x - 2$.

A) $-2x^2 - 4xh - 2h^2 + 2x + 2h - 2$

C) $-2x^2 - 2h^2 - 2x - 2h - 2$

B) $-2x^2 - 2xh - 2h^2 + 2x + 2h - 2$

D) $-2x^2 - 2h^2 + 2x + 2h - 2$

14) Find $f(x + h)$ when $f(x) = \frac{-3x + 7}{8x + 9}$.

A) $\frac{-3x - 3h + 7}{8x + 9}$

B) $\frac{-3x + 4h}{8x + 17h}$

C) $\frac{-3x + 7h}{8x + 9h}$

D) $\frac{-3x - 3h + 7}{8x + 8h + 9}$

Solve the problem.

15) If $f(x) = 8x^3 + 7x^2 - x + C$ and $f(-2) = 1$, what is the value of C ?

A) $C = -1$

B) $C = 35$

C) $C = -93$

D) $C = -37$

16) If $f(x) = \frac{x - B}{x - A}$, $f(9) = 0$, and $f(4)$ is undefined, what are the values of A and B ?

A) $A = 9, B = 4$

B) $A = 4, B = 9$

C) $A = -4, B = -9$

D) $A = -9, B = -4$

17) If $f(x) = \frac{x - 5A}{-15x + 2}$ and $f(-15) = 15$, what is the value of A ?

A) $A = -230$

B) $A = 230$

C) $A = -684$

D) $A = 684$

18) If a rock falls from a height of 30 meters on Earth, the height H (in meters) after x seconds is approximately $H(x) = 30 - 4.9x^2$.

What is the height of the rock when $x = 2$ seconds? Round to the nearest hundredth, if necessary.

A) 10.4 m

B) 20.2 m

C) 49.6 m

D) 10.8 m

19) If a rock falls from a height of 90 meters on Earth, the height H (in meters) after x seconds is approximately $H(x) = 90 - 4.9x^2$.

When does the rock strike the ground? Round to the nearest hundredth, if necessary.

A) 18.37 sec

B) 3.75 sec

C) 1.94 sec

D) 4.29 sec

20) It has been determined that the number of fish $f(t)$ that can be caught in t minutes in a certain pond using a certain bait is $f(t) = 0.27t + 1$, for $t > 10$. Find the approximate number of fish that can be caught if you fish for 20 minutes.

A) About 14 fish

B) About 24 fish

C) About 22 fish

D) About 6 fish

21) The function $P(d) = 1 + \frac{d}{33}$ gives the pressure, in atmospheres (atm), at a depth d feet in the sea. Find the pressure at 55 feet.

A) $\frac{56}{33}$ atm

B) $\frac{2}{3}$ atm

C) $\frac{5}{3}$ atm

D) $\frac{8}{3}$ atm

22) The function F described by $F(C) = \frac{9}{5}C + 32$ gives the Fahrenheit temperature corresponding to the Celsius temperature C . Find the Fahrenheit temperature equivalent to 20°C .

A) 176°F

B) 68°F

C) 140°F

D) 104°F

3 Find the Domain of a Function Defined by an Equation

MULTIPLE CHOICE. Choose the one alternative that best completes the statement or answers the question.

Find the domain of the function.

1) $f(x) = -8x - 3$

A) all real numbers

B) $\{x \mid x > 0\}$

C) $\{x \mid x \neq 0\}$

D) $\{x \mid x \geq 3\}$

2) $f(x) = x^2 + 8$

A) $\{x \mid x > -8\}$

B) $\{x \mid x \geq -8\}$

C) $\{x \mid x \neq -8\}$

D) all real numbers

3) $f(x) = \frac{x}{x^2 + 5}$

A) $\{x \mid x > -5\}$

B) $\{x \mid x \neq 0\}$

C) all real numbers

D) $\{x \mid x \neq -5\}$

4) $g(x) = \frac{3x}{x^2 - 64}$

A) $\{x \mid x > 64\}$

B) all real numbers

C) $\{x \mid x \neq -8, 8\}$

D) $\{x \mid x \neq 0\}$

5) $h(x) = \frac{x - 3}{x^3 - 49x}$

A) $\{x \mid x \neq 0\}$

B) $\{x \mid x \neq 3\}$

C) $\{x \mid x \neq -7, 0, 7\}$

D) all real numbers

6) $f(x) = \sqrt{7 - x}$

A) $\{x \mid x \neq 7\}$

B) $\{x \mid x \neq \sqrt{7}\}$

C) $\{x \mid x \leq \sqrt{7}\}$

D) $\{x \mid x \leq 7\}$

7) $\frac{x}{\sqrt{x - 4}}$

A) all real numbers

B) $\{x \mid x \geq 4\}$

C) $\{x \mid x \neq 4\}$

D) $\{x \mid x > 4\}$

4 Form the Sum, Difference, Product, and Quotient of Two Functions

MULTIPLE CHOICE. Choose the one alternative that best completes the statement or answers the question.

For the given functions f and g , find the requested function and state its domain.

1) $f(x) = 3 - 2x$; $g(x) = -9x + 2$

Find $f + g$.

A) $(f + g)(x) = 7x + 5$; $\{x \mid x \neq \frac{5}{7}\}$

B) $(f + g)(x) = -9x + 3$; $\{x \mid x \neq \frac{1}{3}\}$

C) $(f + g)(x) = -11x + 5$; all real numbers

D) $(f + g)(x) = -6x$; all real numbers

2) $f(x) = 3x - 2$; $g(x) = 7x - 6$

Find $f - g$.

A) $(f - g)(x) = -4x + 4$; all real numbers

B) $(f - g)(x) = -4x - 8$; $\{x \mid x \neq -2\}$

C) $(f - g)(x) = 4x - 4$; all real numbers

D) $(f - g)(x) = 10x - 8$; $\{x \mid x \neq 1\}$

3) $f(x) = 2x + 5$; $g(x) = 5x - 4$

Find $f \cdot g$.

A) $(f \cdot g)(x) = 10x^2 + 21x - 20$; $\{x \mid x \neq -20\}$

B) $(f \cdot g)(x) = 10x^2 + 17x - 20$; all real numbers

C) $(f \cdot g)(x) = 10x^2 - 20$; $\{x \mid x \neq -20\}$

D) $(f \cdot g)(x) = 7x^2 + 17x + 1$; all real numbers

4) $f(x) = 6x + 5$; $g(x) = 5x - 2$

Find $\frac{f}{g}$.

A) $\left(\frac{f}{g}\right)(x) = \frac{6x+5}{5x-2}; \left\{x \mid x \neq -\frac{5}{6}\right\}$
 C) $\left(\frac{f}{g}\right)(x) = \frac{5x-2}{6x+5}; \left\{x \mid x \neq -\frac{5}{6}\right\}$

B) $\left(\frac{f}{g}\right)(x) = \frac{5x-2}{6x+5}; \left\{x \mid x \neq \frac{2}{5}\right\}$
 D) $\left(\frac{f}{g}\right)(x) = \frac{6x+5}{5x-2}; \left\{x \mid x \neq \frac{2}{5}\right\}$

5) $f(x) = 16 - x^2$; $g(x) = 4 - x$

Find $f + g$.

A) $(f + g)(x) = 4 + x; \{x \mid x \neq -4\}$
 C) $(f + g)(x) = -x^2 - x + 20$; all real numbers

B) $(f + g)(x) = -x^2 + x + 12$; all real numbers
 D) $(f + g)(x) = x^3 - 4x^2 - 16x + 64$; all real numbers

6) $f(x) = x - 1$; $g(x) = 4x^2$

Find $f - g$.

A) $(f - g)(x) = -4x^2 + x - 1$; all real numbers
 C) $(f - g)(x) = 4x^2 - x + 1$; all real numbers

B) $(f - g)(x) = 4x^2 + x - 1$; all real numbers
 D) $(f - g)(x) = -4x^2 + x - 1; \{x \mid x \neq 1\}$

7) $f(x) = 4x^3 - 1$; $g(x) = 5x^2 + 1$

Find $f \cdot g$.

A) $(f \cdot g)(x) = 20x^5 + 4x^3 - 5x^2 - 1; \{x \mid x \neq 0\}$
 B) $(f \cdot g)(x) = 20x^5 + 4x^3 - 5x^2 - 1$; all real numbers
 C) $(f \cdot g)(x) = 4x^3 + 5x^2 - 1$; all real numbers
 D) $(f \cdot g)(x) = 20x^6 + 4x^3 - 5x^2 - 1$; all real numbers

8) $f(x) = \sqrt{x}$; $g(x) = 5x - 7$

Find $\frac{f}{g}$.

A) $\left(\frac{f}{g}\right)(x) = \frac{5x-7}{\sqrt{x}}; \{x \mid x \geq 0\}$
 C) $\left(\frac{f}{g}\right)(x) = \frac{\sqrt{x}}{5x-7}; \{x \mid x \neq 0\}$

B) $\left(\frac{f}{g}\right)(x) = \frac{\sqrt{x}}{5x-7}; \left\{x \mid x \geq 0, x \neq \frac{7}{5}\right\}$
 D) $\left(\frac{f}{g}\right)(x) = \frac{\sqrt{x}}{5x-7}; \left\{x \mid x \neq \frac{7}{5}\right\}$

9) $f(x) = \sqrt{5-x}$; $g(x) = \sqrt{x-1}$

Find $f \cdot g$.

A) $(f \cdot g)(x) = \sqrt{-x^2 - 5}; \{x \mid x \neq 5\}$
 C) $(f \cdot g)(x) = \sqrt{(5-x)(x-1)}; \{x \mid 1 \leq x \leq 5\}$

B) $(f \cdot g)(x) = \sqrt{(5-x)(x-1)}; \{x \mid x \neq 1, x \neq 5\}$
 D) $(f \cdot g)(x) = \sqrt{(5-x)(x-1)}; \{x \mid x \geq 0\}$

10) $f(x) = \frac{8x-5}{3x-8}$; $g(x) = \frac{4x}{3x-8}$

Find $f + g$.

A) $(f + g)(x) = \frac{12x-5}{3x-8}; \{x \mid x \neq 0\}$
 C) $(f + g)(x) = \frac{12x-5}{3x-8}; \left\{x \mid x \neq \frac{8}{3}, x \neq \frac{5}{12}\right\}$

B) $(f + g)(x) = \frac{12x-5}{3x-8}; \left\{x \mid x \neq \frac{8}{3}\right\}$
 D) $(f + g)(x) = \frac{4x+5}{3x-8}; \left\{x \mid x \neq \frac{8}{3}\right\}$

11) $f(x) = \sqrt{x+5}$; $g(x) = \frac{2}{x}$

Find $f \cdot g$.

A) $(f \cdot g)(x) = \frac{2\sqrt{x+5}}{x}$; $\{x | x \geq -5, x \neq 0\}$

B) $(f \cdot g)(x) = \sqrt{\frac{2x+10}{x}}$; $\{x | x \geq -5, x \neq 0\}$

C) $(f \cdot g)(x) = \frac{\sqrt{2x+10}}{x}$; $\{x | x \geq -5, x \neq 0\}$

D) $(f \cdot g)(x) = \sqrt{\frac{7}{x}}$; $\{x | x \neq 0\}$

Solve the problem.

12) Given $f(x) = \frac{1}{x}$ and $(\frac{f}{g})(x) = \frac{x+4}{x^2-7x}$, find the function g .

A) $g(x) = \frac{x+4}{x-7}$

B) $g(x) = \frac{x-7}{x+4}$

C) $g(x) = \frac{x+7}{x-4}$

D) $g(x) = \frac{x-4}{x+7}$

13) Find $(f+g)(1)$ when $f(x) = x-5$ and $g(x) = x+6$.

A) 1

B) 3

C) -9

D) 13

14) Find $(f-g)(1)$ when $f(x) = -3x^2+4$ and $g(x) = x-4$.

A) 6

B) -4

C) -2

D) 4

15) Find $(fg)(-3)$ when $f(x) = x-5$ and $g(x) = 5x^2+14x-4$.

A) -2

B) 8

C) 82

D) 296

16) Find $(\frac{f}{g})(-4)$ when $f(x) = 5x-2$ and $g(x) = 5x^2+14x+2$.

A) 0

B) $\frac{5}{18}$

C) $-\frac{11}{13}$

D) $\frac{5}{26}$

Find and simplify the difference quotient of f , $\frac{f(x+h)-f(x)}{h}$, $h \neq 0$, for the function.

17) $f(x) = 5x+1$

A) $5 + \frac{10(x+1)}{h}$

B) 0

C) 5

D) $5 + \frac{2}{h}$

18) $f(x) = 8x^2$

A) $\frac{16}{h} + x + 8h$

B) $\frac{8(2x^2+2xh+h^2)}{h}$

C) 8

D) $8(2x+h)$

19) $f(x) = 6$

A) 6

B) 0

C) 1

D) $1 + \frac{12}{h}$

20) $f(x) = \frac{1}{6x}$

A) $\frac{-1}{x(x+h)}$

B) $\frac{1}{6x}$

C) 0

D) $\frac{-1}{6x(x+h)}$

21) $f(x) = x^2 + 6x + 7$

A) $2x + h + 6$

C) 1

B) $\frac{2x^2 + 2x + 2xh + h^2 + h + 14}{h}$

D) $2x + h + 7$

Solve the problem.

22) Express the gross salary G of a person who earns \$30 per hour as a function of the number x of hours worked.

A) $G(x) = \frac{30}{x}$

B) $G(x) = 30x^2$

C) $G(x) = 30 + x$

D) $G(x) = 30x$

23) Jacey, a commissioned salesperson, earns \$290 base pay plus \$44 per item sold. Express Jacey's gross salary G as a function of the number x of items sold.

A) $G(x) = 44(x + 290)$

B) $G(x) = 44x + 290$

C) $G(x) = 290(x + 44)$

D) $G(x) = 290x + 44$

24) Suppose that $P(x)$ represents the percentage of income spent on food in year x and $I(x)$ represents income in year x . Determine a function F that represents total food expenditures in year x .

A) $F(x) = (I - P)(x)$

B) $F(x) = \left(\frac{I}{P}\right)(x)$

C) $F(x) = (P \cdot I)(x)$

D) $F(x) = (P + I)(x)$

25) A furniture store buys 100 footstools from a distributor at a cost of \$230 each plus an overhead charge of \$50 per order. The retail markup is 25% on the total price paid. Find the profit on the sale of one footstool.

A) \$57.50

B) \$5763.00

C) \$57.38

D) \$57.63

26) The following graph shows the private, public and total national school enrollment for students for select years from 1980 through 2010.

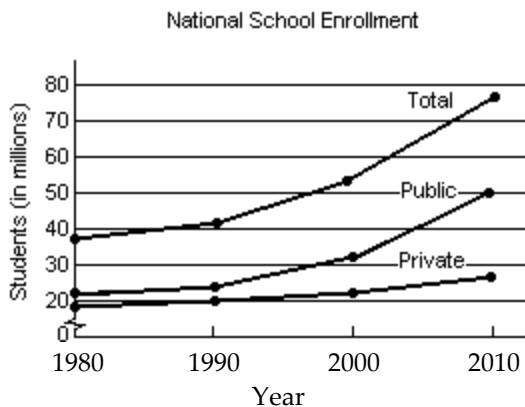

i) How is the graph for total school enrollment, T , determined from the graph of the private enrollment, r , and the public enrollment, u ?

ii) During which 10-year period did the total number of students enrolled increase the least?

iii) During which 10-year period did the total number of students enrolled increase the most?

A) i) T is the sum of r and u .

B) i) T is the sum of r and u .

ii) 1980 - 1990

ii) 2000-2010

iii) 2000-2010

iii) 1980-1990

C) i) T is the difference of r and u .

D) i) T is the sum of r and u .

ii) 1990 - 1990

ii) 1980 - 1990

iii) 2000-2010

iii) 1990-2000

27) A firm is considering a new product. The accounting department estimates that the total cost, $C(x)$, of producing x units will be

$$C(x) = 100x + 4240.$$

The sales department estimates that the revenue, $R(x)$, from selling x units will be

$$R(x) = 110x,$$

but that no more than 482 units can be sold at that price. Find and interpret $(R - C)(482)$.

- | | |
|--|---|
| A) \$906 profit, income exceeds cost
It is worth it to develop product. | B) -\$580 loss, cost exceeds income
It is not worth it to develop product. |
| C) \$105,460 profit, income exceeds cost
It is worth it to develop product. | D) \$580 profit, income exceeds cost
It is worth it to develop product. |

28) The function $f(t) = -0.14t^2 + 0.49t + 31.8$ models a certain country's population in millions, ages 65 and older, where t represents years after 2010. The function $g(t) = 0.56t^2 + 12.32t + 107.1$ models the total yearly cost of the government's health insurance program in billions of dollars, where t represents years after 2010. What does the function $\frac{g}{f}$ represent? Find $\left(\frac{g}{f}\right)(5)$.

- A) Cost per person in thousands of dollars. \$0.21 thousand
 B) Cost per person in thousands of dollars. \$5.94 thousand
 C) Cost per person in thousands of dollars. \$12.71 thousand
 D) Cost per person in thousands of dollars. \$0.17 thousand

2.2 The Graph of a Function

1 Identify the Graph of a Function

MULTIPLE CHOICE. Choose the one alternative that best completes the statement or answers the question.

Determine whether the graph is that of a function. If it is, use the graph to find its domain and range, the intercepts, if any, and any symmetry with respect to the x -axis, the y -axis, or the origin.

1)

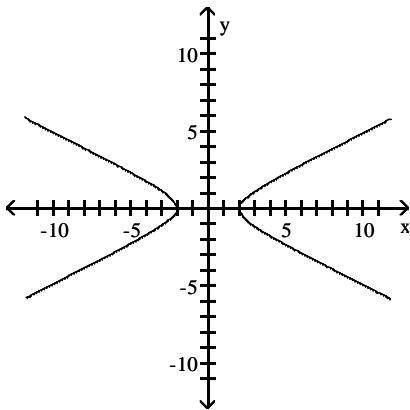

- | | |
|--|--|
| A) function
domain: all real numbers
range: $\{y \mid y \leq -2 \text{ or } y \geq 2\}$
intercepts: $(-2, 0), (2, 0)$
symmetry: y -axis | B) function
domain: $\{x \mid -2 \leq x \leq 2\}$
range: all real numbers
intercepts: $(-2, 0), (2, 0)$
symmetry: x -axis, y -axis |
| C) function
domain: $\{x \mid x \leq -2 \text{ or } x \geq 2\}$
range: all real numbers
intercepts: $(-2, 0), (2, 0)$
symmetry: x -axis, y -axis, origin | D) not a function |

2)

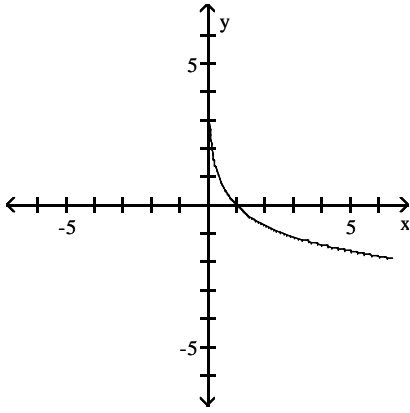

A) function

domain: $\{x \mid x > 0\}$

range: all real numbers

intercept: $(0, 1)$

symmetry: origin

C) function

domain: $\{x \mid x > 0\}$

range: all real numbers

intercept: $(1, 0)$

symmetry: none

B) function

domain: all real numbers

range: $\{y \mid y > 0\}$

intercept: $(1, 0)$

symmetry: none

D) not a function

3)

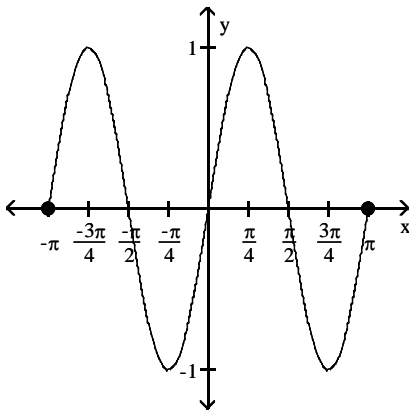

A) function

domain: $\{x \mid -\pi \leq x \leq \pi\}$

range: $\{y \mid -1 \leq y \leq 1\}$

intercepts: $(-\pi, 0), (-\frac{\pi}{2}, 0), (0, 0), (\frac{\pi}{2}, 0), (\pi, 0)$

symmetry: origin

C) function

domain: $\{x \mid -1 \leq x \leq 1\}$

range: $\{y \mid -\pi \leq y \leq \pi\}$

intercepts: $(-\pi, 0), (-\frac{\pi}{2}, 0), (0, 0), (\frac{\pi}{2}, 0), (\pi, 0)$

symmetry: none

B) function

domain: all real numbers

range: $\{y \mid -1 \leq y \leq 1\}$

intercepts: $(-\pi, 0), (-\frac{\pi}{2}, 0), (0, 0), (\frac{\pi}{2}, 0), (\pi, 0)$

symmetry: origin

D) not a function

4)

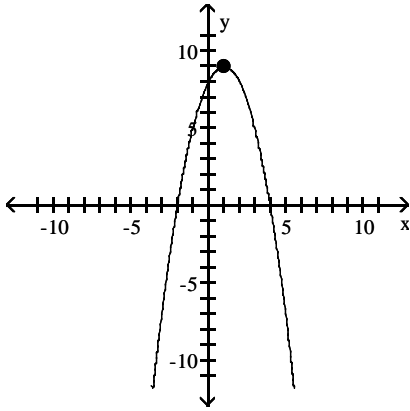

A) function

domain: $\{x \mid x \leq 9\}$

range: all real numbers

intercepts: $(-2, 0)$, $(0, 8)$, $(4, 0)$

symmetry: y-axis

C) function

domain: all real numbers

range: $\{y \mid y \leq 9\}$

intercepts: $(0, -2)$, $(8, 0)$, $(0, 4)$

symmetry: none

B) function

domain: all real numbers

range: $\{y \mid y \leq 9\}$

intercepts: $(-2, 0)$, $(0, 8)$, $(4, 0)$

symmetry: none

D) not a function

5)

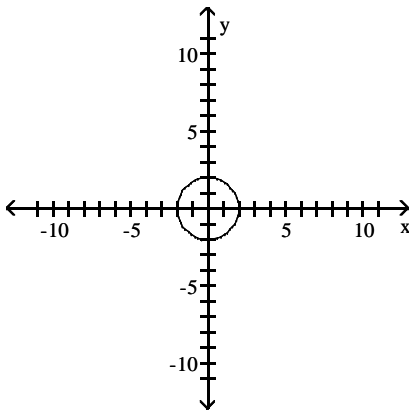

A) function

domain: $\{x \mid -2 \leq x \leq 2\}$

range: $\{y \mid -2 \leq y \leq 2\}$

intercepts: $(-2, 0)$, $(0, -2)$, $(0, 2)$, $(2, 0)$

symmetry: x-axis, y-axis, origin

C) function

domain: $\{x \mid -2 \leq x \leq 2\}$

range: $\{y \mid -2 \leq y \leq 2\}$

intercepts: $(-2, 0)$, $(0, -2)$, $(0, 2)$, $(2, 0)$

symmetry: x-axis, y-axis

B) function

domain: $\{x \mid -2 \leq x \leq 2\}$

range: $\{y \mid -2 \leq y \leq 2\}$

intercepts: $(-2, 0)$, $(0, -2)$, $(0, 0)$, $(0, 2)$, $(2, 0)$

symmetry: origin

D) not a function

6)

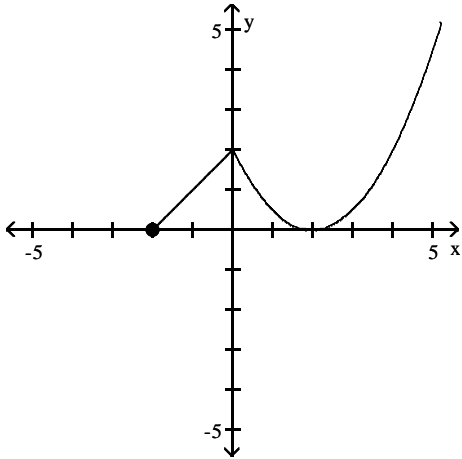

A) function

domain: all real numbers

range: all real numbers

intercepts: $(-2, 0)$, $(0, 2)$, $(2, 0)$

symmetry: none

C) function

domain: $\{x \mid x \geq -2\}$

range: $\{y \mid y \geq 0\}$

intercepts: $(-2, 0)$, $(0, 2)$, $(2, 0)$

symmetry: none

B) function

domain: $\{x \mid x \geq 0\}$

range: $\{y \mid y \geq -2\}$

intercepts: $(-2, 0)$, $(0, 2)$, $(2, 0)$

symmetry: y-axis

D) not a function

7)

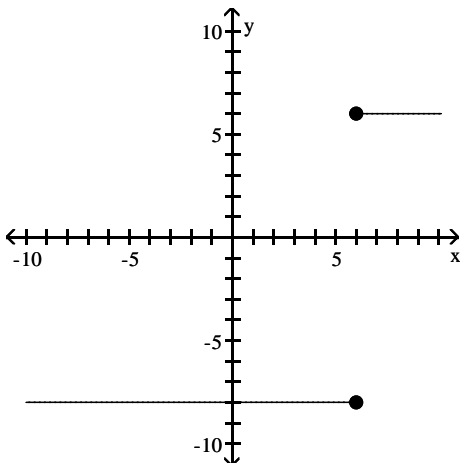

A) function

domain: all real numbers

range: all real numbers

intercept: $(0, -8)$

symmetry: none

C) function

domain: all real numbers

range: $\{y \mid y = 6 \text{ or } y = -8\}$

intercept: $(0, -8)$

symmetry: none

B) function

domain: $\{x \mid x = 6 \text{ or } x = -8\}$

range: all real numbers

intercept: $(-8, 0)$

symmetry: x-axis

D) not a function

2 Obtain Information from or about the Graph of a Function

MULTIPLE CHOICE. Choose the one alternative that best completes the statement or answers the question.

The graph of a function f is given. Use the graph to answer the question.

1) Use the graph of f given below to find $f(4)$.

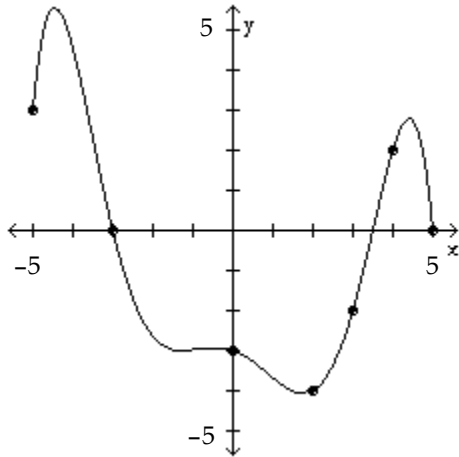

A) 4

B) 2

C) 7

D) 5

2) Is $f(16)$ positive or negative?

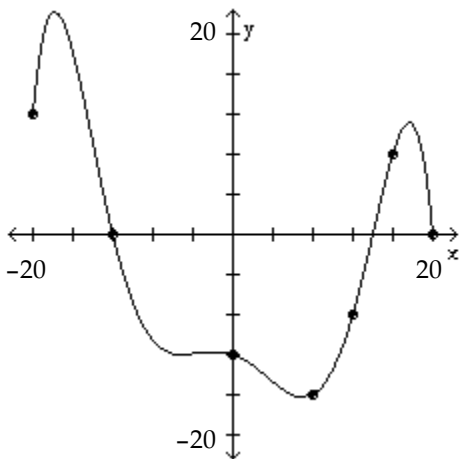

A) positive

B) negative

3) Is $f(3)$ positive or negative?

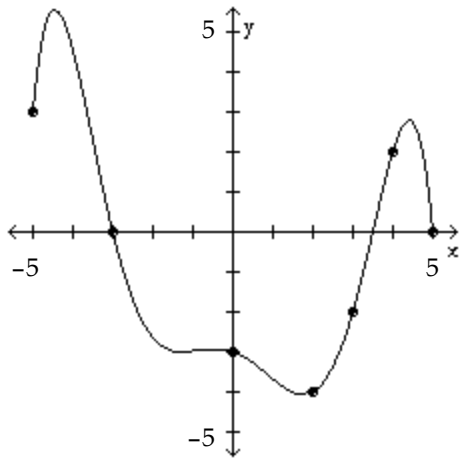

A) positive

B) negative

4) For what numbers x is $f(x) = 0$?

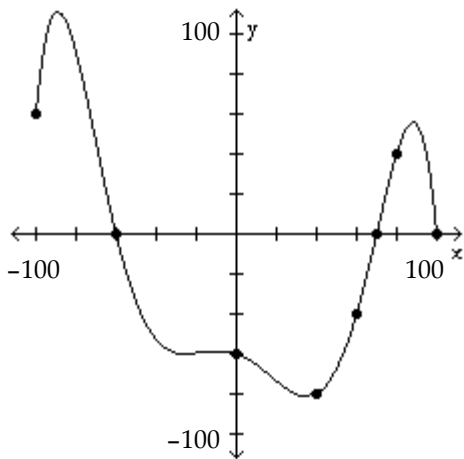

A) $(-60, 70)$

B) $(-100, -60), (70, 100)$

C) $-60, 70, 100$

D) -60

5) For what numbers x is $f(x) > 0$?

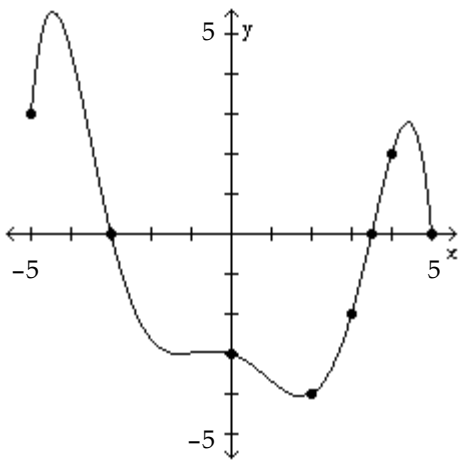

A) $(-\infty, -3)$

B) $(-3, 3.5)$

C) $[-5, -3), (3.5, 5)$

D) $(-3, \infty)$

6) For what numbers x is $f(x) < 0$?

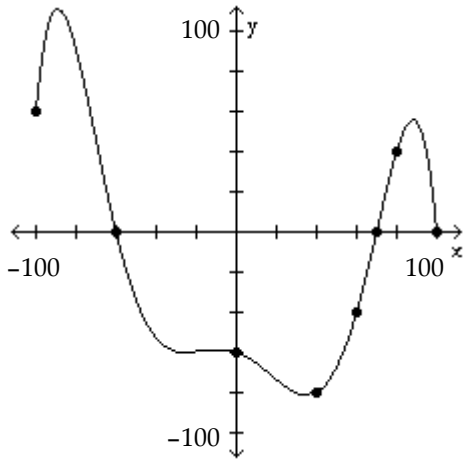

- A) $(-60, 70)$
- C) $(-60, \infty)$

- B) $(-\infty, -60)$
- D) $[-100, -60), (70, 100)$

7) What is the domain of f ?

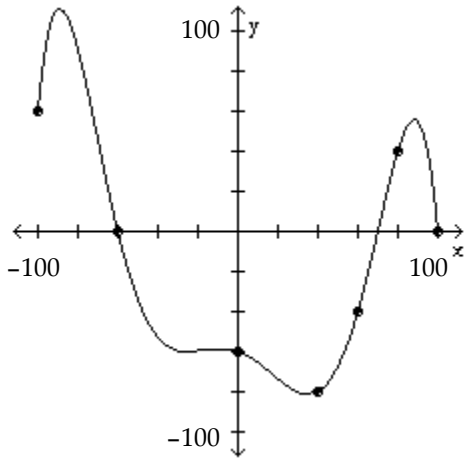

- A) $\{x \mid -80 \leq x \leq 110\}$

- B) $\{x \mid x \geq 0\}$

- C) $\{x \mid -100 \leq x \leq 100\}$

- D) all real numbers

8) What are the x -intercepts?

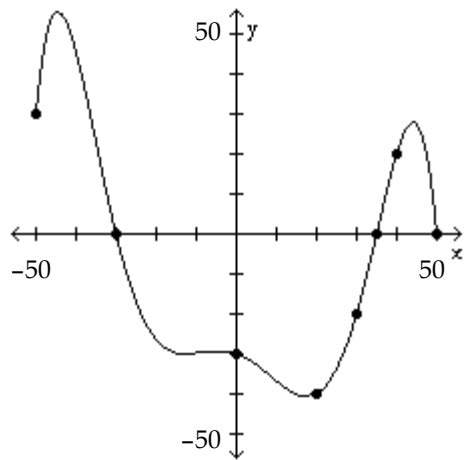

- A) -30

- B) -50, -30, 35, 50

- C) -30, 35

- D) -30, 35, 50

9) What is the y-intercept?

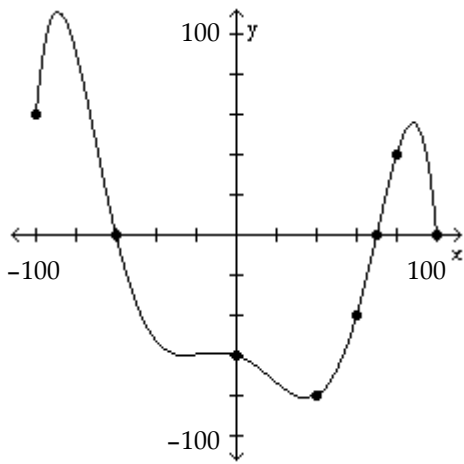

- A) -60 B) 100 C) -80 D) 70

10) How often does the line $y = -50$ intersect the graph?

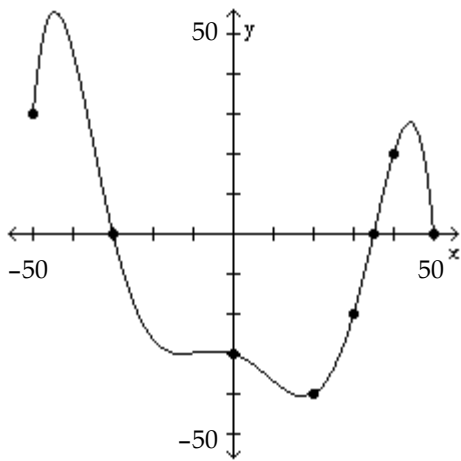

- A) once B) twice C) three times D) does not intersect

11) How often does the line $y = 1$ intersect the graph?

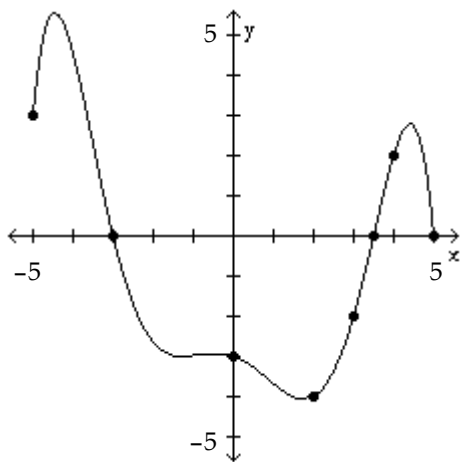

- A) once B) twice C) three times D) does not intersect

12) For which of the following values of x does $f(x) = -8$?

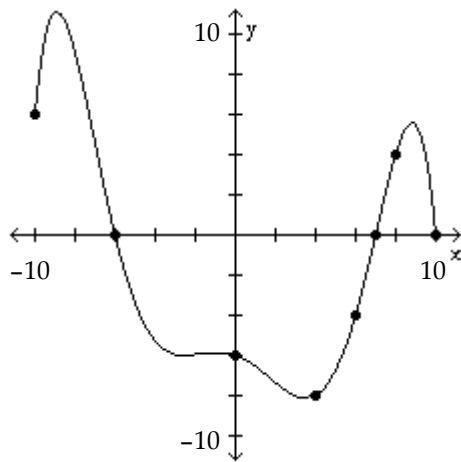

A) 6

B) -8

C) 0

D) 4

Answer the question about the given function.

13) Given the function $f(x) = 5x^2 + 10x - 7$, is the point $(-1, -12)$ on the graph of f ?

A) Yes

B) No

14) Given the function $f(x) = 4x^2 + 8x - 1$, is the point $(-2, 7)$ on the graph of f ?

A) Yes

B) No

15) Given the function $f(x) = -5x^2 - 10x + 7$, if $x = -1$, what is $f(x)$? What point is on the graph of f ?

A) 12; $(-1, 12)$

B) 12; $(12, -1)$

C) -8; $(-1, -8)$

D) -8; $(-8, -1)$

16) Given the function $f(x) = -3x^2 - 6x - 6$, what is the domain of f ?

A) all real numbers

B) $\{x \mid x \geq -1\}$

C) $\{x \mid x \leq -1\}$

D) $\{x \mid x \geq 1\}$

17) Given the function $f(x) = x^2 + 3x - 54$, list the x -intercepts, if any, of the graph of f .

A) $(-9, 0)$, $(1, 0)$

B) $(9, 0)$, $(-6, 0)$

C) $(9, 0)$, $(6, 0)$

D) $(-9, 0)$, $(6, 0)$

18) Given the function $f(x) = -4x^2 - 8x - 5$, list the y -intercept, if there is one, of the graph of f .

A) -5

B) -13

C) -1

D) -17

19) Given the function $f(x) = \frac{x^2 - 7}{x + 3}$, is the point $(1, -\frac{3}{2})$ on the graph of f ?

A) Yes

B) No

20) Given the function $f(x) = \frac{x^2 - 8}{x - 1}$, is the point $(2, 12)$ on the graph of f ?

A) Yes

B) No

21) Given the function $f(x) = \frac{x^2 - 9}{x + 3}$, if $x = -2$, what is $f(x)$? What point is on the graph of f ?

A) -5; $(-5, -2)$

B) 13; $(-2, 13)$

C) 13; $(13, -2)$

D) -5; $(-2, -5)$

22) Given the function $f(x) = \frac{x^2 + 8}{x + 6}$, what is the domain of f ?

- A) $\{x \mid x \neq 6\}$ B) $\{x \mid x \neq -\frac{4}{3}\}$ C) $\{x \mid x \neq 8\}$ D) $\{x \mid x \neq -6\}$

23) Given the function $f(x) = \frac{x^2 + 2}{x - 4}$, list the x -intercepts, if any, of the graph of f .

- A) $(2, 0), (-2, 0)$ B) $(-\sqrt{2}, 0)$ C) $(4, 0)$ D) none

24) Given the function $f(x) = \frac{x^2 + 7}{x + 5}$, list the y -intercept, if there is one, of the graph of f .

- A) $(0, -7)$ B) $(0, -5)$ C) $(\frac{7}{5}, 0)$ D) $(0, \frac{7}{5})$

Solve the problem.

25) If an object weighs m pounds at sea level, then its weight W (in pounds) at a height of h miles above sea level is given approximately by $W(h) = m \left(\frac{4000}{4000 + h} \right)^2$. How much will a man who weighs 165 pounds at sea level weigh on the top of a mountain which is 14,494 feet above sea level? Round to the nearest hundredth of a pound, if necessary.

- A) 164.77 pounds B) 7.72 pounds C) 165 pounds D) 165.23 pounds

Match the function with the graph that best describes the situation.

26) The amount of rainfall as a function of time, if the rain fell more and more softly.

A)

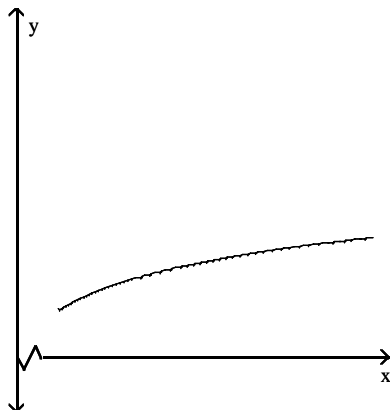

B)

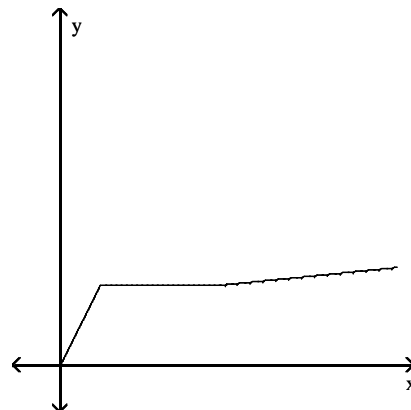

C)

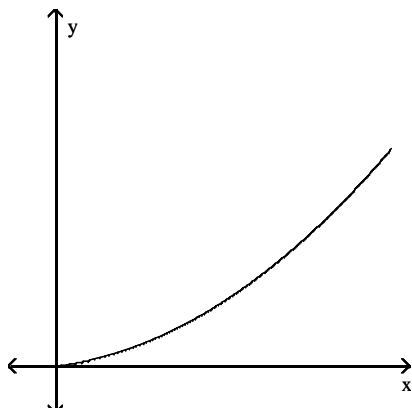

D)

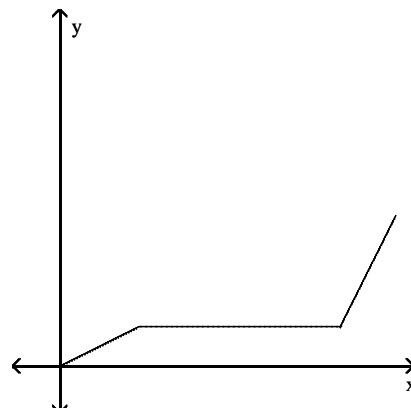

27) The height of an animal as a function of time.

A)

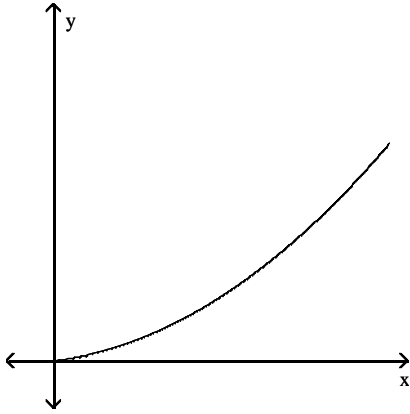

B)

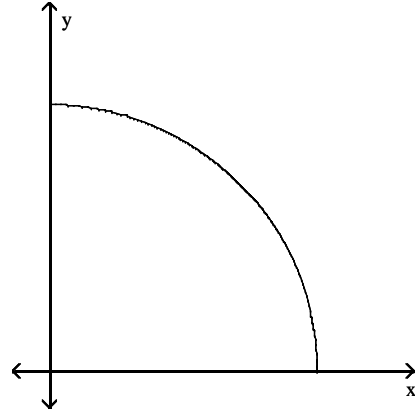

C)

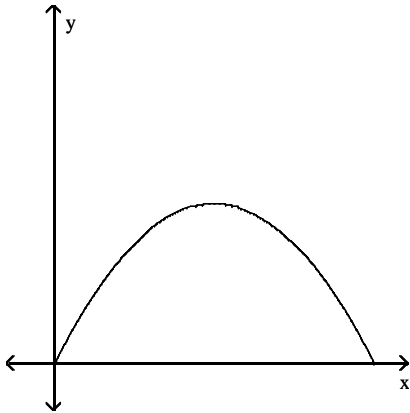

D)

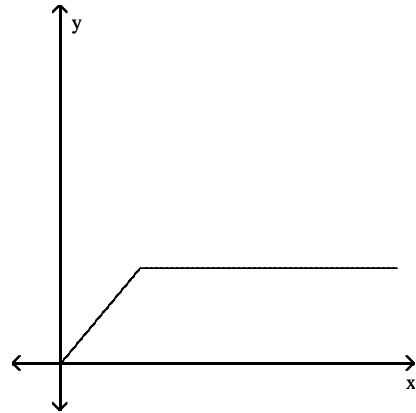

SHORT ANSWER. Write the word or phrase that best completes each statement or answers the question.

Solve the problem.

28) Michael decides to walk to the mall to do some errands. He leaves home, walks 3 blocks in 10 minutes at a constant speed, and realizes that he forgot his wallet at home. So Michael runs back in 6 minutes. At home, it takes him 2 minutes to find his wallet and close the door. Michael walks 2 blocks in 8 minutes and then decides to jog to the mall. It takes him 4 minutes to get to the mall which is 2 blocks away. Draw a graph of Michael's distance from home (in blocks) as a function of time.

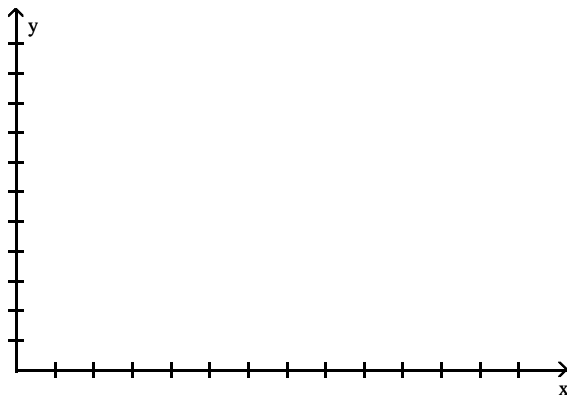

MULTIPLE CHOICE. Choose the one alternative that best completes the statement or answers the question.

- 29) A steel can in the shape of a right circular cylinder must be designed to hold 550 cubic centimeters of juice (see figure). It can be shown that the total surface area of the can (including the ends) is given by $S(r) = 2\pi r^2 + \frac{1100}{r}$, where r is the radius of the can in centimeters. Using the TABLE feature of a graphing utility, find the radius that minimizes the surface area (and thus the cost) of the can. Round to the nearest tenth of a centimeter.

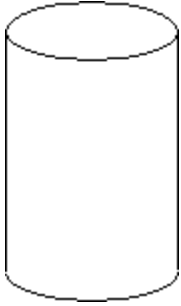

- A) 4.4 cm B) 3.6 cm C) 5.6 cm D) 0 cm
- 30) The concentration C (arbitrary units) of a certain drug in a patient's bloodstream can be modeled using $C(t) = \frac{t}{(0.471t + 2.121)^2}$, where t is the number of hours since a 500 milligram oral dose was administered. Using the TABLE feature of a graphing utility, find the time at which the concentration of the drug is greatest. Round to the nearest tenth of an hour.
- A) 6 hours B) 4.5 hours C) 6.8 hours D) 5.3 hours

2.3 Properties of Functions

1 Determine Even and Odd Functions from a Graph

MULTIPLE CHOICE. Choose the one alternative that best completes the statement or answers the question.

The graph of a function is given. Decide whether it is even, odd, or neither.

1)

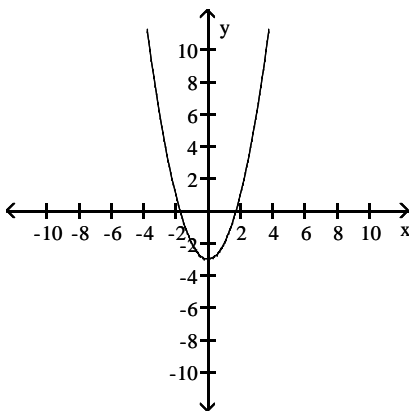

- A) even B) odd C) neither

2)

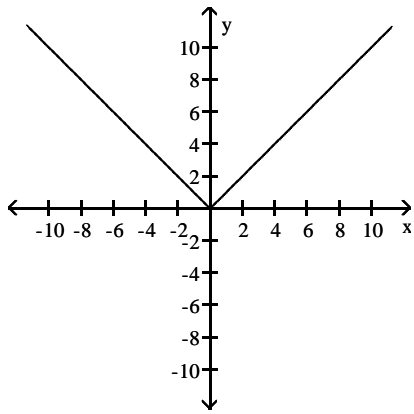

A) even

B) odd

C) neither

3)

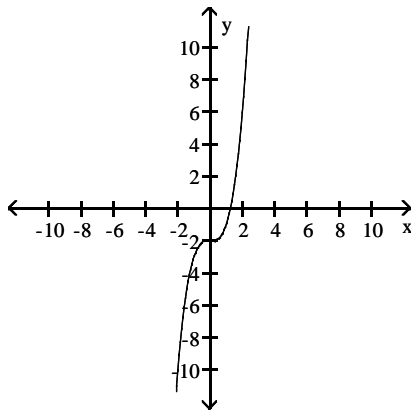

A) even

B) odd

C) neither

4)

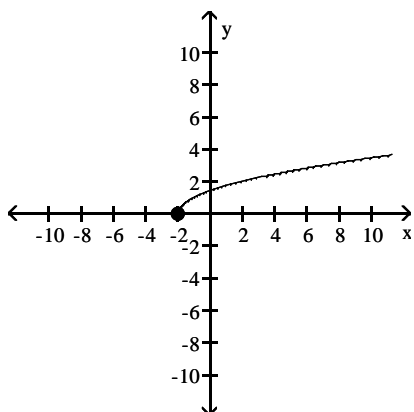

A) even

B) odd

C) neither

5)

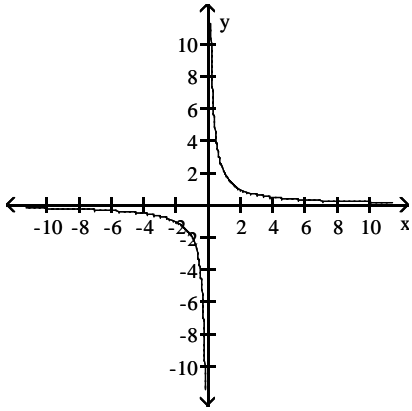

A) even

B) odd

C) neither

6)

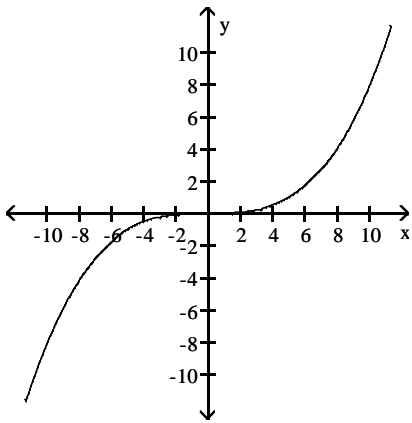

A) even

B) odd

C) neither

7)

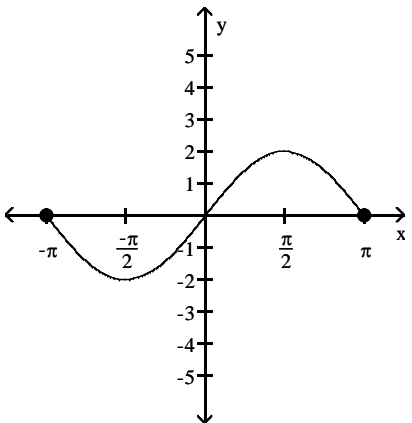

A) even

B) odd

C) neither

8)

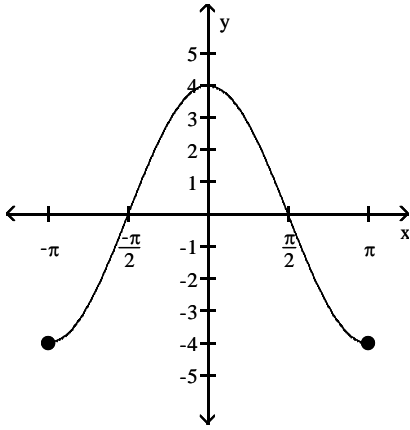

A) even

B) odd

C) neither

2 Identify Even and Odd Functions from the Equation

MULTIPLE CHOICE. Choose the one alternative that best completes the statement or answers the question.

Determine algebraically whether the function is even, odd, or neither.

1) $f(x) = 5x^3$

A) even

B) odd

C) neither

2) $f(x) = 3x^4 - x^2$

A) even

B) odd

C) neither

3) $f(x) = -4x^2 + 3$

A) even

B) odd

C) neither

4) $f(x) = 3x^3 + 9$

A) even

B) odd

C) neither

5) $f(x) = \sqrt[3]{x}$

A) even

B) odd

C) neither

6) $f(x) = \sqrt{x}$

A) even

B) odd

C) neither

7) $\sqrt[3]{7x^2 + 3}$

A) even

B) odd

C) neither

8) $f(x) = \frac{1}{x^2}$

A) even

B) odd

C) neither

9) $f(x) = \frac{x}{x^2 + 4}$

A) even

B) odd

C) neither

$$10) f(x) = \frac{-x^3}{6x^2 + 9}$$

A) even

B) odd

C) neither

$$11) f(x) = \frac{4x}{|x|}$$

A) even

B) odd

C) neither

3 Use a Graph to Determine Where a Function is Increasing, Decreasing, or Constant

MULTIPLE CHOICE. Choose the one alternative that best completes the statement or answers the question.

The graph of a function is given. Determine whether the function is increasing, decreasing, or constant on the given interval.

1) $(-3, -\frac{3}{2})$

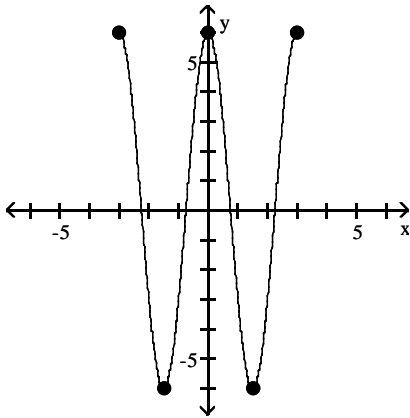

A) constant

B) increasing

C) decreasing

2) $(-2, 0)$

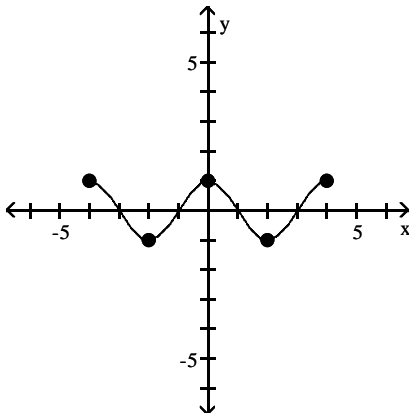

A) increasing

B) constant

C) decreasing

3) (0, 1)

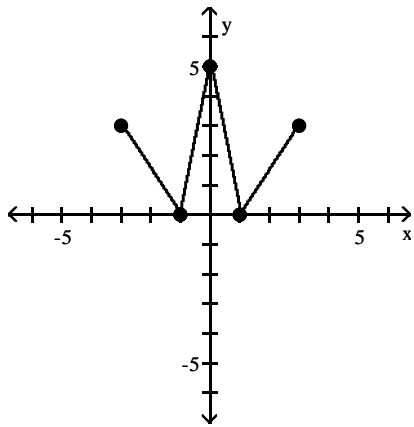

A) increasing

B) decreasing

C) constant

4) (1, 3)

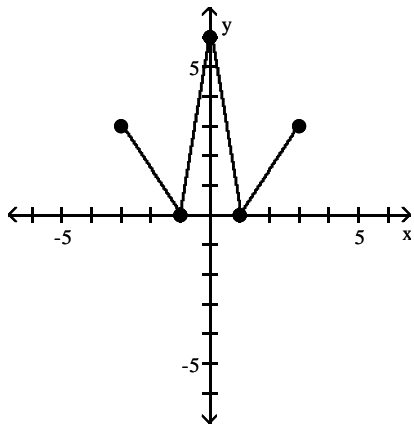

A) decreasing

B) constant

C) increasing

5) (0, 1)

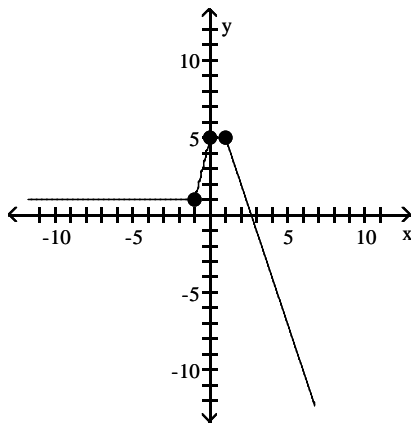

A) constant

B) decreasing

C) increasing

6) $(-2, 0)$

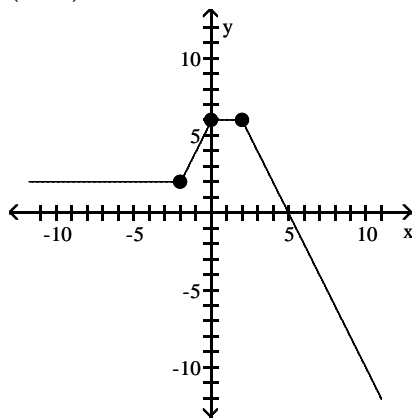

A) constant

B) decreasing

C) increasing

7) $(3, \infty)$

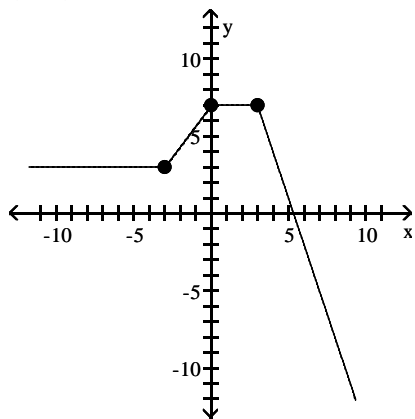

A) decreasing

B) constant

C) increasing

8) $(-1, \infty)$

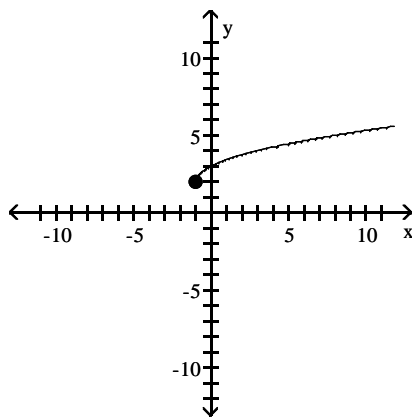

A) decreasing

B) constant

C) increasing

9) $(-2, -1)$

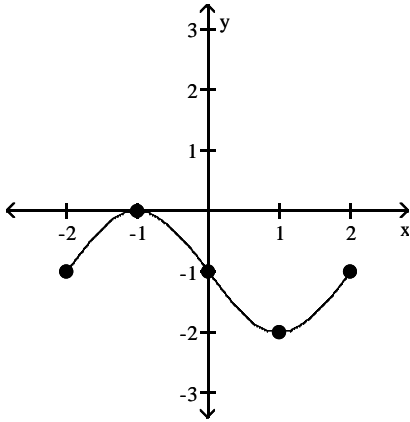

A) decreasing

B) constant

C) increasing

10) $(-3, 0.5)$

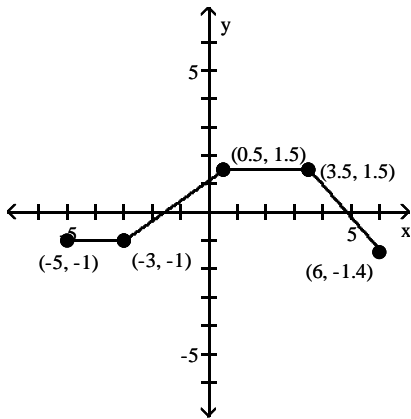

A) constant

B) decreasing

C) increasing

11) $(-1, 0)$

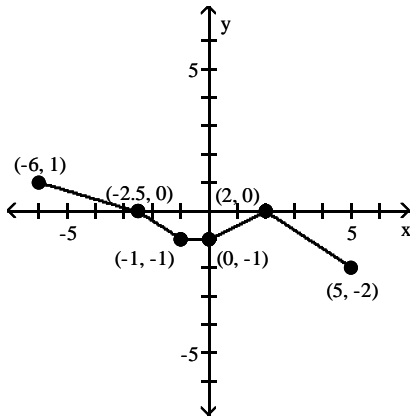

A) constant

B) increasing

C) decreasing

12) $(-8, -2.5)$

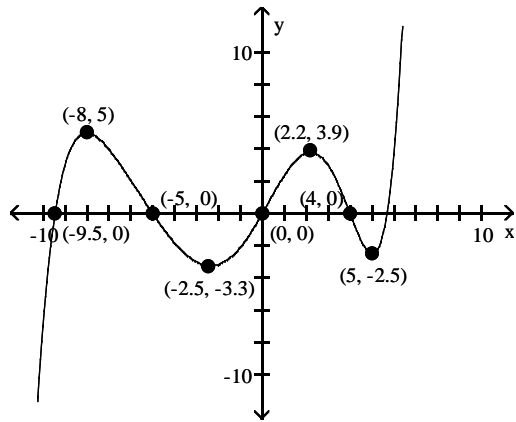

A) increasing

B) decreasing

C) constant

Use the graph to find the intervals on which it is increasing, decreasing, or constant.

13)

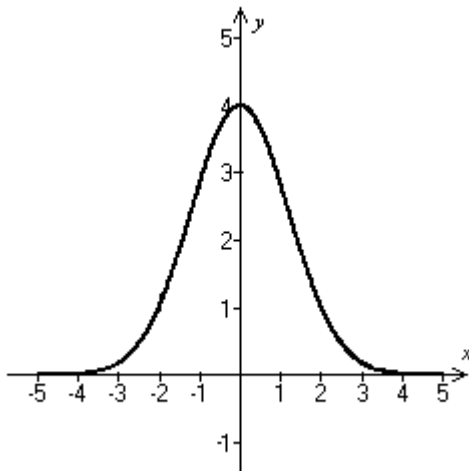

A) Decreasing on $(-\infty, \infty)$

C) Increasing on $(-\infty, 0)$; decreasing on $(0, \infty)$

B) Decreasing on $(-\infty, 0)$; increasing on $(0, \infty)$

D) Increasing on $(-\infty, \infty)$

14)

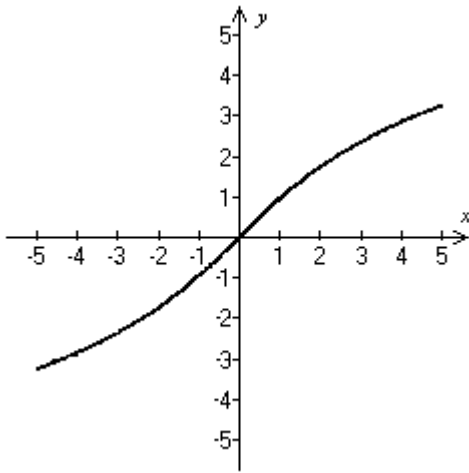

- A) Increasing on $(-\infty, \infty)$
- C) Decreasing on $(-\infty, 0)$; increasing on $(0, \infty)$

- B) Decreasing on $(-\infty, \infty)$
- D) Increasing on $(-\infty, 0)$; decreasing on $(0, \infty)$

15)

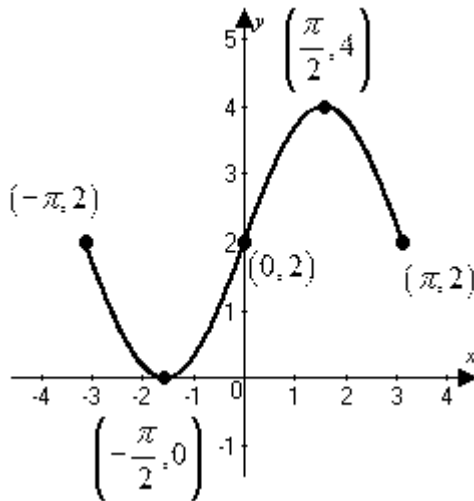

- A) Decreasing on $\left[-\pi, -\frac{\pi}{2}\right]$ and $\left[\frac{\pi}{2}, \pi\right]$; increasing on $\left[-\frac{\pi}{2}, \frac{\pi}{2}\right]$
- B) Decreasing on $(-\pi, 0)$; increasing on $(0, \pi)$
- C) Increasing on $(-\infty, \infty)$
- D) Increasing on $\left[-\pi, -\frac{\pi}{2}\right]$ and $\left[\frac{\pi}{2}, \pi\right]$; decreasing on $\left[-\frac{\pi}{2}, \frac{\pi}{2}\right]$

16)

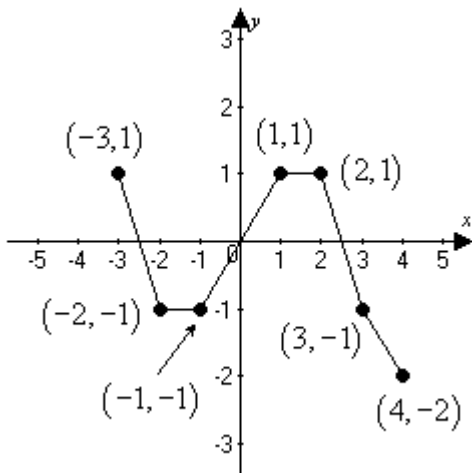

- A) Decreasing on $(-3, -2)$ and $(2, 4)$; increasing on $(-1, 1)$; constant on $(-2, -1)$ and $(1, 2)$
- B) Increasing on $(-3, -2)$ and $(2, 4)$; decreasing on $(-1, 1)$; constant on $(-2, -1)$ and $(1, 2)$
- C) Decreasing on $(-3, -2)$ and $(2, 4)$; increasing on $(-1, 1)$
- D) Decreasing on $(-3, -1)$ and $(1, 4)$; increasing on $(-2, 1)$

4 Use a Graph to Locate Local Maxima and Local Minima

MULTIPLE CHOICE. Choose the one alternative that best completes the statement or answers the question.

The graph of a function f is given. Use the graph to answer the question.

- 1) Find the numbers, if any, at which f has a local maximum. What are the local maxima?

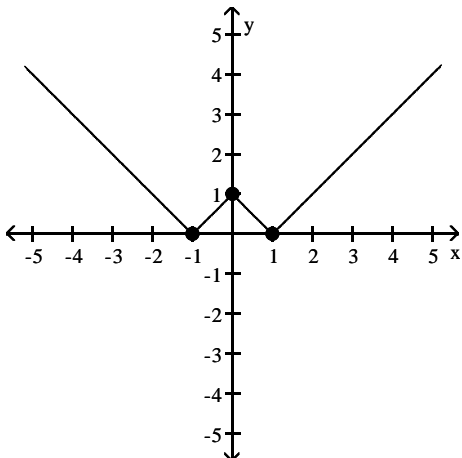

- A) f has a local maximum at $x = 1$; the local maximum is 1
- B) f has a local maximum at $x = 0$; the local maximum is 1
- C) f has a local maximum at $x = -1$ and 1; the local maximum is 0
- D) f has no local maximum

2) Find the numbers, if any, at which f has a local minimum. What are the local minima?

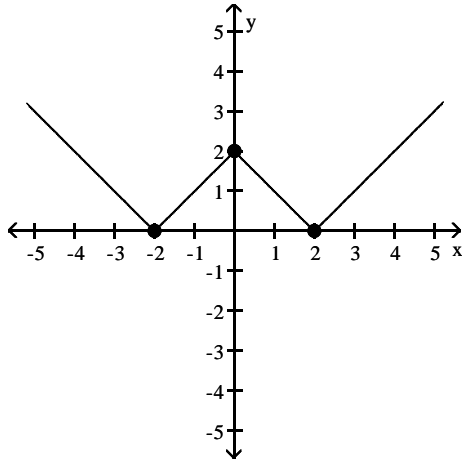

- A) f has a local minimum at $x = 0$; the local minimum is 2
- B) f has a local minimum at $x = -2$ and 2 ; the local minimum is 0
- C) f has a local minimum at $x = -2$; the local minimum is 0
- D) f has no local minimum

3) Find the numbers, if any, at which f has a local maximum. What are the local maxima?

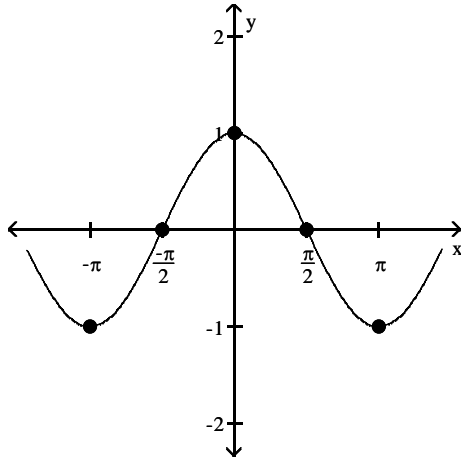

- A) f has a local maximum at $x = -\pi$ and π ; the local maximum is -1
- B) f has a local maximum at $-\pi$; the local maximum is 1
- C) f has no local maximum
- D) f has a local maximum at $x = 0$; the local maximum is 1

4) Find the numbers, if any, at which f has a local minimum. What are the local minima?

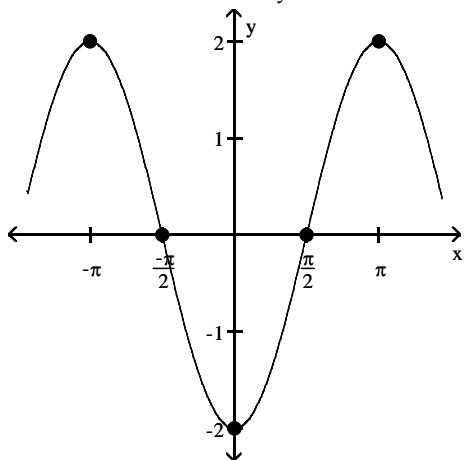

- A) f has a local minimum at $x = -\pi$ and π ; the local minimum is 2
- B) f has a local minimum at $x = -\pi$; the local minimum is -2
- C) f has a local minimum at $x = 0$; the local minimum is -2
- D) f has no local minimum

5)

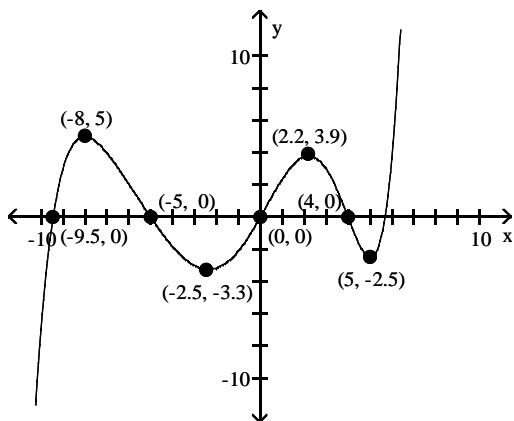

Find the numbers, if any, at which f has a local maximum. What are the local maxima?

- A) f has a local minimum at $x = 5$ and 3.9 ; the local minimum at 5 is -8 ; the local minimum at 3.9 is 2.2
- B) f has a local maximum at $x = -8$ and 2.2 ; the local maximum at -8 is 5 ; the local maximum at 2.2 is 3.9
- C) f has a local maximum at $x = 5$ and 3.9 ; the local maximum at 5 is -8 ; the local maximum at 3.9 is 2.2
- D) f has a local minimum at $x = -8$ and 2.2 ; the local minimum at -8 is 5 ; the local minimum at 2.2 is 3.9

Solve the problem.

- 6) The height s of a ball (in feet) thrown with an initial velocity of 60 feet per second from an initial height of 3 feet is given as a function of time t (in seconds) by $s(t) = -16t^2 + 60t + 3$. What is the maximum height? Round to the nearest hundredth, if necessary.

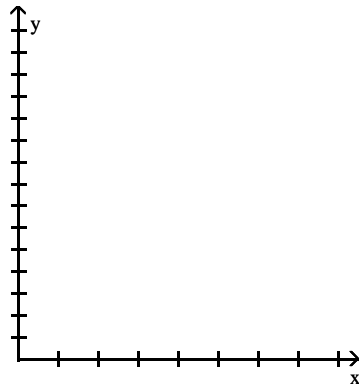

- A) 68.63 ft B) 59.25 ft C) 56.44 ft D) -37.31 ft

5 Use a Graph to Locate the Absolute Maximum and the Absolute Minimum

MULTIPLE CHOICE. Choose the one alternative that best completes the statement or answers the question.

For the graph of the function $y = f(x)$, find the absolute maximum and the absolute minimum, if it exists.

1)

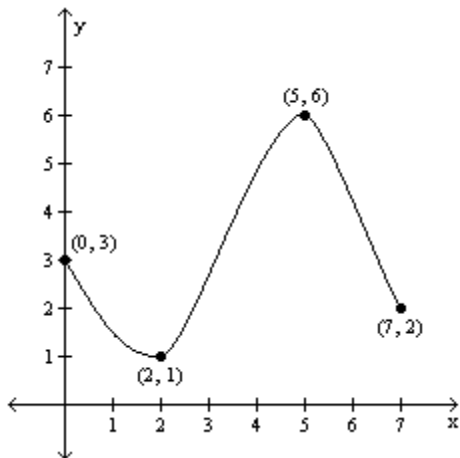

- A) Absolute maximum: $f(7) = 2$; Absolute minimum: $f(0) = 3$
B) Absolute maximum: $f(6) = 5$; Absolute minimum: $f(1) = 2$
C) Absolute maximum: $f(2) = 7$; Absolute minimum: $f(3) = 0$
D) Absolute maximum: $f(5) = 6$; Absolute minimum: $f(2) = 1$

2)

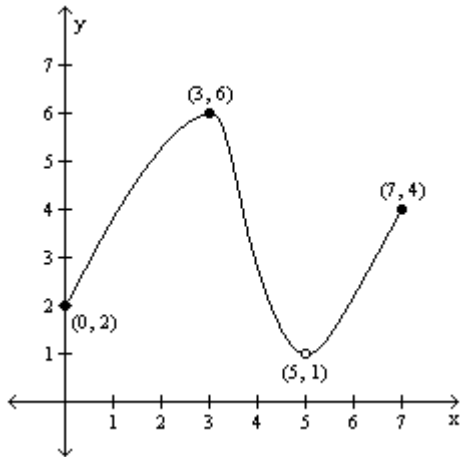

- A) Absolute maximum: $f(3) = 6$; Absolute minimum: none
- B) Absolute maximum: $f(3) = 6$; Absolute minimum: $f(0) = 2$
- C) Absolute maximum: $f(7) = 4$; Absolute minimum: $f(0) = 2$
- D) Absolute maximum: $f(3) = 6$; Absolute minimum: $f(5) = 1$

3)

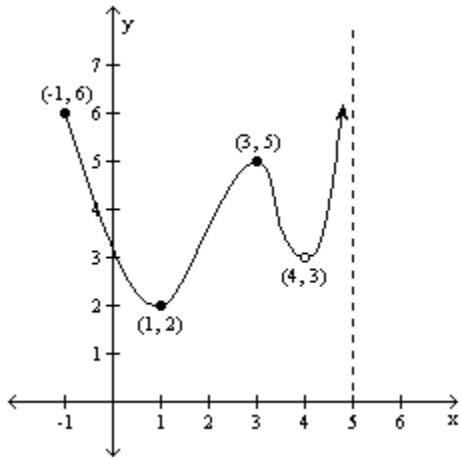

- A) Absolute maximum: $f(-1) = 6$; Absolute minimum: $f(1) = 2$
- B) Absolute maximum: none; Absolute minimum: $f(1) = 2$
- C) Absolute maximum: none; Absolute minimum: none
- D) Absolute maximum: $f(3) = 5$; Absolute minimum: $f(1) = 2$

4)

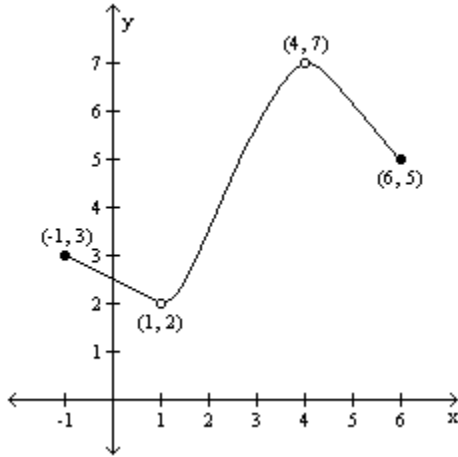

- A) Absolute maximum: none; Absolute minimum: $f(1) = 2$
- B) Absolute maximum: $f(4) = 7$; Absolute minimum: none
- C) Absolute maximum: $f(4) = 7$; Absolute minimum: $f(1) = 2$
- D) Absolute maximum: none; Absolute minimum: none

6 Use Graphing Utility to Approximate Local Maxima/Minima & Determine Where Func is Increasing/Decreasing

MULTIPLE CHOICE. Choose the one alternative that best completes the statement or answers the question.

Use a graphing utility to graph the function over the indicated interval and approximate any local maxima and local minima. Determine where the function is increasing and where it is decreasing. If necessary, round answers to two decimal places.

1) $f(x) = x^3 - 3x^2 + 1, (-1, 3)$

- A) local maximum at $(0, 1)$
local minimum at $(2, -3)$
increasing on $(0, 2)$
decreasing on $(-1, 0)$ and $(2, 3)$
- C) local maximum at $(2, -3)$
local minimum at $(0, 1)$
increasing on $(-1, 0)$
decreasing on $(0, 2)$

- B) local maximum at $(0, 1)$
local minimum at $(2, -3)$
increasing on $(-1, 0)$ and $(2, 3)$
decreasing on $(0, 2)$
- D) local maximum at $(2, -3)$
local minimum at $(0, 1)$
increasing on $(-1, 0)$ and $(2, 3)$
decreasing on $(0, 2)$

2) $f(x) = x^3 - 4x^2 + 6; (-1, 4)$

- A) local maximum at $(0, 6)$
local minimum at $(2.67, -3.48)$
increasing on $(-1, 0)$ and $(2.67, 4)$
decreasing on $(0, 2.67)$
- C) local maximum at $(2.67, -3.48)$
local minimum at $(0, 6)$
increasing on $(0, 2.67)$
decreasing on $(-1, 0)$ and $(2.67, 4)$

- B) local maximum at $(2.67, -3.48)$
local minimum at $(0, 6)$
increasing on $(-1, 0)$ and $(2.67, 4)$
decreasing on $(0, 2.67)$
- D) local maximum at $(0, 6)$
local minimum at $(2.67, -3.48)$
increasing on $(0, 2.67)$
decreasing on $(-1, 0)$ and $(2.67, 4)$

- 3) $f(x) = x^5 - x^2$; $(-2, 2)$
- A) local maximum at $(0, 0)$
 local minimum at $(0.74, -0.33)$
 increasing on $(-2, 0)$ and $(0.74, 2)$
 decreasing on $(0, 0.74)$
- B) local maximum at $(0.74, -0.33)$
 local minimum at $(0, 0)$
 increasing on $(0, 0.74)$
 decreasing on $(-2, 0)$ and $(0.74, 2)$
- C) local maximum at $(0, 0)$
 local minimum at $(0.74, -0.33)$
 increasing on $(0, 0.74)$
 decreasing on $(-2, 0)$ and $(0.74, 2)$
- D) local maximum at $(0.74, -0.33)$
 local minimum at $(0, 0)$
 increasing on $(-2, 0)$ and $(0.74, 2)$
 decreasing on $(0, 0.74)$
- 4) $f(x) = -0.3x^3 + 0.2x^2 + 4x - 5$; $(-4, 5)$
- A) local maximum at $(-1.9, -9.82)$
 local minimum at $(2.34, 1.61)$
 increasing on $(-4, -1.9)$ and $(2.34, 5)$
 decreasing on $(-1.9, 2.34)$
- B) local maximum at $(-1.9, -9.82)$
 local minimum at $(2.34, 1.61)$
 increasing on $(-1.9, 2.34)$
 decreasing on $(-4, -1.9)$ and $(2.34, 5)$
- C) local maximum at $(2.34, 1.61)$
 local minimum at $(-1.9, -9.82)$
 increasing on $(-1.9, 2.34)$
 decreasing on $(-4, -1.9)$ and $(2.34, 5)$
- D) local maximum at $(2.34, 1.61)$
 local minimum at $(-1.9, -9.82)$
 increasing on $(-4, -1.9)$ and $(2.34, 5)$
 decreasing on $(-1.9, 2.34)$
- 5) $f(x) = 0.15x^4 + 0.3x^3 - 0.8x^2 + 5$; $(-4, 2)$
- A) local maximum at $(0, 5)$
 local minima at $(-2.55, 1.17)$ and $(1.05, 4.65)$
 increasing on $(-4, -2.55)$ and $(0, 1.05)$
 decreasing on $(-2.55, 0)$ and $(1.05, 2)$
- B) local maximum at $(-2.55, 1.17)$ and $(1.05, 4.65)$
 local minima at $(0, 5)$
 increasing on $(-2.55, 0)$ and $(1.05, 2)$
 decreasing on $(-4, -2.55)$ and $(0, 1.05)$
- C) local maximum at $(0, 5)$
 local minima at $(-2.55, 1.17)$ and $(1.05, 4.65)$
 increasing on $(-2.55, 0)$ and $(1.05, 2)$
 decreasing on $(-4, -2.55)$ and $(0, 1.05)$
- D) local maximum at $(-2.55, 1.17)$ and $(1.05, 4.65)$
 local minima at $(0, 5)$
 increasing on $(-4, -2.55)$ and $(0, 1.05)$
 decreasing on $(-2.55, 0)$ and $(1.05, 2)$

Use a graphing utility to graph the function over the indicated interval and approximate any local maxima and local minima. If necessary, round answers to two decimal places.

- 6) $f(x) = x^2 + 2x - 3$; $(-5, 5)$
- A) local minimum at $(1, 4)$
 C) local maximum at $(1, -4)$
- B) local minimum at $(-1, -4)$
 D) local maximum at $(-1, 4)$
- 7) $f(x) = 2 + 8x - x^2$; $(-5, 5)$
- A) local minimum at $(4, 50)$
 C) local maximum at $(-4, 50)$
- B) local minimum at $(-4, 18)$
 D) local maximum at $(4, 18)$
- 8) $f(x) = x^3 - 3x^2 + 1$; $(-5, 5)$
- A) local minimum at $(0, 1)$
 local maximum at $(2, -3)$
 C) local minimum at $(2, -3)$
- B) none
 D) local maximum at $(0, 1)$
 local minimum at $(2, -3)$
- 9) $f(x) = x^3 - 12x + 2$; $(-5, 5)$
- A) local maximum at $(-2, 18)$
 local minimum at $(0, 0)$
 local minimum at $(2, -14)$
 C) local minimum at $(0, 0)$
- B) none
 D) local maximum at $(-2, 18)$
 local minimum at $(2, -14)$

- 10) $f(x) = x^4 - 5x^3 + 3x^2 + 9x - 3$; $(-5, 5)$
- | | |
|--|---|
| A) local minimum at $(-3, -3)$
local maximum at $(-1.32, 5.64)$
local minimum at $(0.57, -6.12)$ | B) local minimum at $(-0.61, -5.64)$
local maximum at $(1.41, 6.12)$
local minimum at $(3, -3)$ |
| C) local minimum at $(-1, -6)$
local maximum at $(1, 6)$
local minimum at $(3, -3)$ | D) local minimum at $(-0.57, -6.12)$
local maximum at $(1.32, 5.64)$
local minimum at $(3, -3)$ |

Solve.

- 11) John owns a hotdog stand. He has found that his profit is represented by the equation $P(x) = -x^2 + 62x + 76$, with P being profits and x the number of hotdogs sold. How many hotdogs must he sell to earn the most profit?
- A) 31 hotdogs B) 22 hotdogs C) 45 hotdogs D) 32 hotdogs
- 12) Bob owns a watch repair shop. He has found that the cost of operating his shop is given by $c(x) = 3x^2 - 240x + 58$, where c is cost and x is the number of watches repaired. How many watches must he repair to have the lowest cost?
- A) 40 watches B) 58 watches C) 29 watches D) 30 watches
- 13) John owns a hotdog stand. His profit is represented by the equation $P(x) = -x^2 + 14x + 58$, with P being profits and x the number of hotdogs sold. What is the most he can earn?
- A) \$135 B) \$93 C) \$49 D) \$107
- 14) A rock falls from a tower that is 142.1 m high. As it is falling, its height is given by the formula $h(t) = 142.1 - 4.9t^2$. How many seconds will it take for the rock to hit the ground ($h=0$)? Round to the nearest tenth.
- A) 4100 sec B) 29.2 sec C) 11.9 sec D) 5.4 sec
- 15) A projectile is thrown upward so that its distance above the ground after t seconds is $h(t) = -16t^2 + 572t$. After how many seconds does it reach its maximum height? Round to the nearest second.
- A) 18 sec B) 33 sec C) 11 sec D) 44 sec
- 16) A rock falls from a tower that is 240 ft high. As it is falling, its height is given by the formula $h(t) = 240 - 16t^2$. How many seconds will it take for the rock to hit the ground ($h=0$)? Round to the nearest tenth.
- A) 15.5 sec B) 3.9 sec C) 3600 sec D) 15.2 sec

7 Find the Average Rate of Change of a Function

MULTIPLE CHOICE. Choose the one alternative that best completes the statement or answers the question.

For the function, find the average rate of change of f from 1 to x : $\frac{f(x) - f(1)}{x - 1}, x \neq 1$

- 1) $f(x) = 7x$
- | | | | |
|------|------|------|----------------------|
| A) 6 | B) 0 | C) 7 | D) $\frac{7}{x - 1}$ |
|------|------|------|----------------------|
- 2) $f(x) = x^3 - x$
- | | | | |
|--------------|------|--------------------------------|--------------|
| A) $x^2 - x$ | B) 1 | C) $\frac{x^3 - x - 1}{x - 1}$ | D) $x^2 + x$ |
|--------------|------|--------------------------------|--------------|

$$3) f(x) = \frac{4}{x+3}$$

$$A) \frac{4}{x(x+3)}$$

$$B) \frac{4}{(x-1)(x+3)}$$

$$C) \frac{1}{x+3}$$

$$D) -\frac{1}{x+3}$$

$$4) f(x) = \sqrt{x+3}$$

$$A) \frac{\sqrt{x+3}+2}{x-1}$$

$$B) \frac{\sqrt{x+3}-2}{x+1}$$

$$C) \frac{\sqrt{x+3}+2}{x+1}$$

$$D) \frac{\sqrt{x+3}-2}{x-1}$$

Find the average rate of change for the function between the given values.

$$5) f(x) = -3x + 6; \text{ from 1 to 2}$$

$$A) -6$$

$$B) -3$$

$$C) 3$$

$$D) 6$$

$$6) f(x) = x^2 + 2x; \text{ from 4 to 8}$$

$$A) 7$$

$$B) 20$$

$$C) 10$$

$$D) 14$$

$$7) f(x) = 4x^3 + 7x^2 + 4; \text{ from -8 to -4}$$

$$A) 35$$

$$B) -364$$

$$C) 364$$

$$D) -35$$

$$8) f(x) = \sqrt{2x}; \text{ from 2 to 8}$$

$$A) \frac{1}{3}$$

$$B) 2$$

$$C) -\frac{3}{10}$$

$$D) 7$$

$$9) f(x) = \frac{3}{x-2}; \text{ from 4 to 7}$$

$$A) -\frac{3}{10}$$

$$B) \frac{1}{3}$$

$$C) 7$$

$$D) 2$$

$$10) f(x) = 4x^2; \text{ from 0 to } \frac{7}{4}$$

$$A) -\frac{3}{10}$$

$$B) 7$$

$$C) 2$$

$$D) \frac{1}{3}$$

$$11) f(x) = -3x^2 - x; \text{ from 5 to 6}$$

$$A) -34$$

$$B) \frac{1}{2}$$

$$C) -\frac{1}{6}$$

$$D) -2$$

$$12) f(x) = x^3 + x^2 - 8x - 7; \text{ from 0 to 2}$$

$$A) -2$$

$$B) \frac{1}{2}$$

$$C) -\frac{1}{6}$$

$$D) -28$$

$$13) f(x) = \sqrt{2x-1}; \text{ from 1 to 5}$$

$$A) \frac{1}{2}$$

$$B) -28$$

$$C) -2$$

$$D) -\frac{1}{6}$$

$$14) f(x) = \frac{3}{x+2}; \text{ from 1 to 4}$$

$$A) -2$$

$$B) -\frac{1}{6}$$

$$C) -28$$

$$D) \frac{1}{2}$$

Find an equation of the secant line containing (1, f(1)) and (2, f(2)).

15) $f(x) = x^3 - x$

A) $y = 6x - 6$

B) $y = -6x + 6$

C) $y = -6x - 6$

D) $y = 6x + 6$

16) $f(x) = \frac{4}{x+3}$

A) $y = \frac{4}{5}x + \frac{1}{5}$

B) $y = \frac{1}{5}x + \frac{4}{5}$

C) $y = -\frac{1}{5}x + \frac{6}{5}$

D) $y = \frac{1}{5}x + \frac{3}{2}$

17) $f(x) = \sqrt{x+99}$

A) $y = (-\sqrt{101} - 10)x - \sqrt{101} + 20$

B) $y = (\sqrt{101} - 10)x + \sqrt{101} - 20$

C) $y = (\sqrt{101} - 10)x - \sqrt{101} + 20$

D) $y = (-\sqrt{101} + 10)x + \sqrt{101} - 20$

Solve the problem.

- 18) From April through December, the stock price of QRS Company had a roller coaster ride. The chart below indicates the price of the stock at the beginning of each month during that period. Find the monthly average rate of change in price between June and September.

Month	Price (in \$)
April (x = 1)	114
May	108
June	87
July	99
August	94
September	113
October	93
November	84
December	65

A) -\$13.00 per month

B) -\$8.67 per month

C) \$8.67 per month

D) \$13.00 per month

- 19) Along with incomes, people's charitable contributions have steadily increased over the past few years. The table below shows the average deduction for charitable contributions reported on individual income tax returns over a six year period. Find the average rate of change between year 3 and year 5.

Year	Charitable Contributions
1	\$1940
2	\$2380
3	\$2460
4	\$2800
5	\$3020
6	\$3200

A) \$560 per year

B) \$370 per year

C) \$320 per year

D) \$280 per year

- 20) A deep sea diving bell is being lowered at a constant rate. After 8 minutes, the bell is at a depth of 500 feet. After 45 minutes the bell is at a depth of 1700 feet. What is the average rate of lowering per minute? Round to the nearest hundredth if necessary.

A) 32.43 ft per min

B) 37.78 ft per min

C) 0.03 ft per min

D) 26.67 ft per min

2.4 Library of Functions; Piecewise-defined Functions

1 Graph the Functions Listed in the Library of Functions

MULTIPLE CHOICE. Choose the one alternative that best completes the statement or answers the question.

Match the graph to the function listed whose graph most resembles the one given.

1)

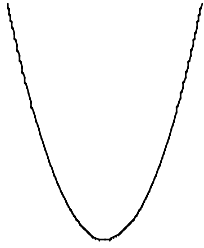

- A) cube function
- C) square function

- B) absolute value function
- D) reciprocal function

2)



- A) constant function
- C) linear function

- B) absolute value function
- D) reciprocal function

3)

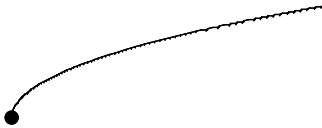

- A) cube function
- C) square function

- B) square root function
- D) cube root function

4)

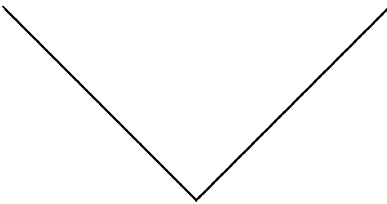

- A) reciprocal function
- C) absolute value function

- B) linear function
- D) square function

5)

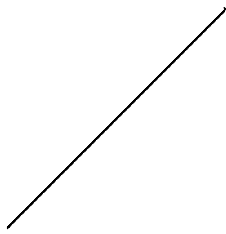

- A) linear function
- C) reciprocal function

- B) constant function
- D) absolute value function

6)



- A) square root function
- C) cube root function

- B) square function
- D) cube function

7)

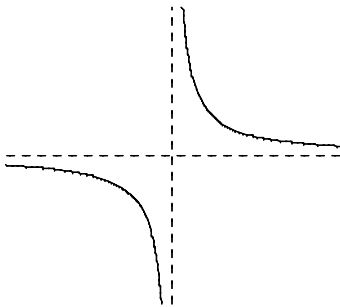

- A) reciprocal function
- C) square root function

- B) absolute value function
- D) square function

8)



- A) square function
- C) cube root function

- B) square root function
- D) cube function

Graph the function.

9) $f(x) = x$

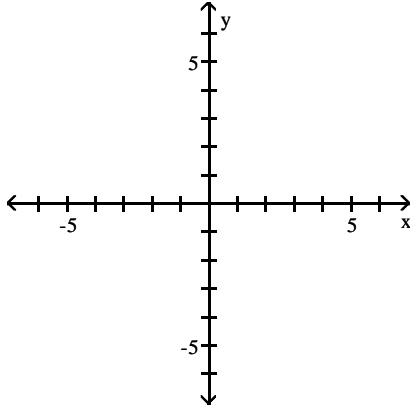

A)

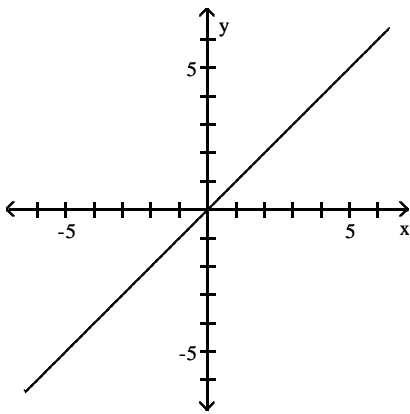

B)

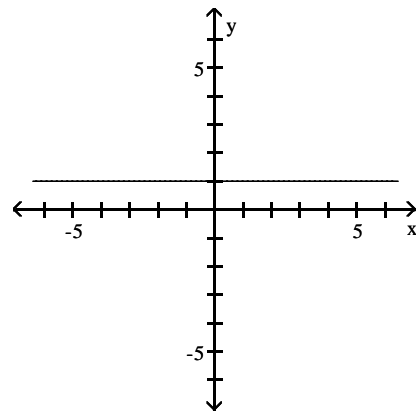

C)

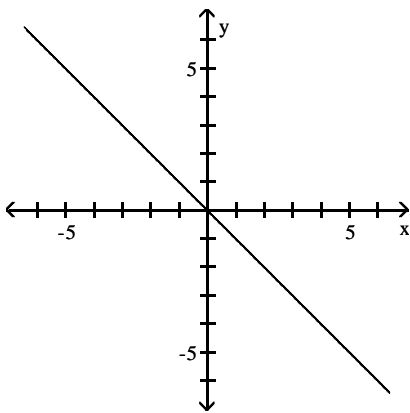

D)

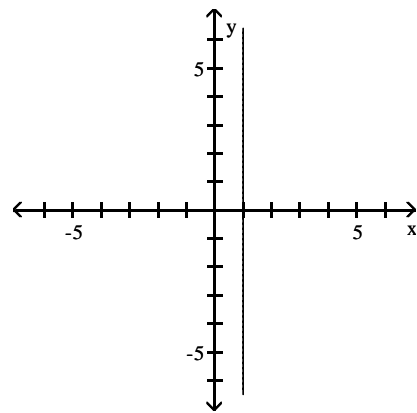

10) $f(x) = x^2$

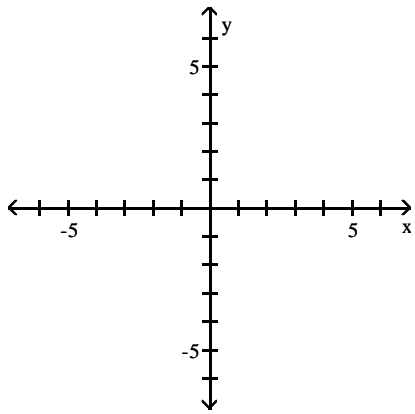

A)

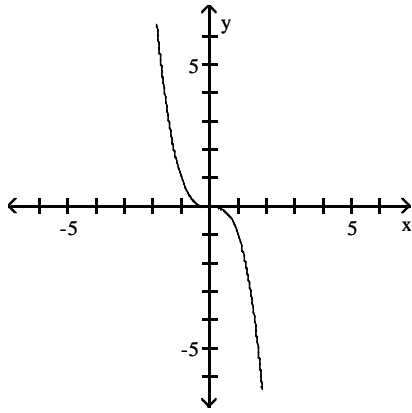

B)

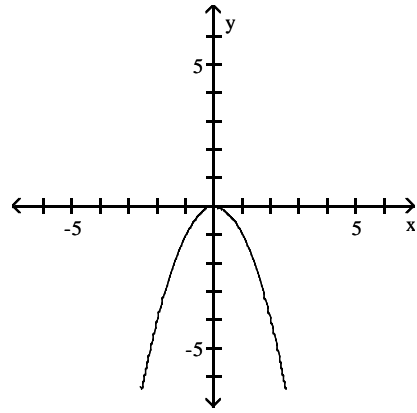

C)

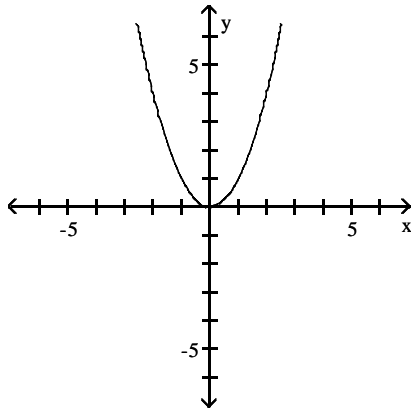

D)

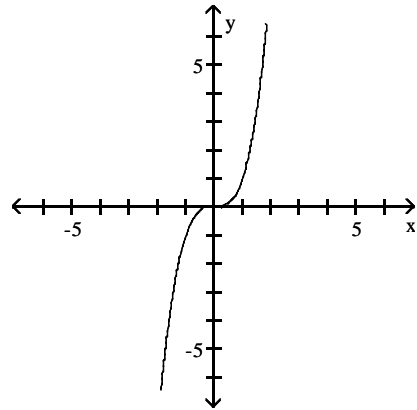

11) $f(x) = x^3$

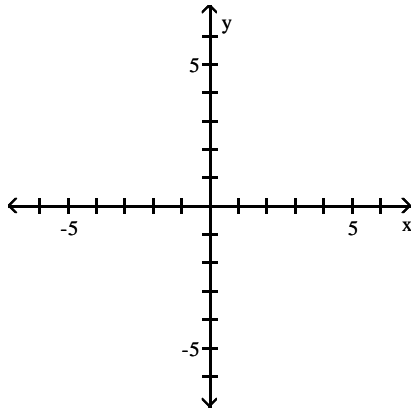

A)

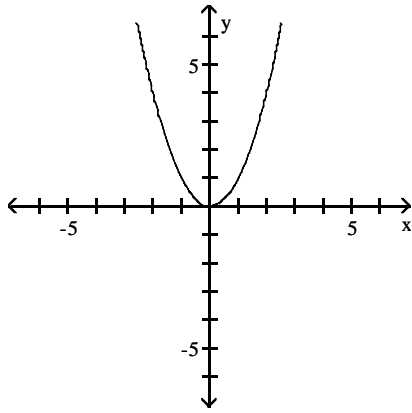

B)

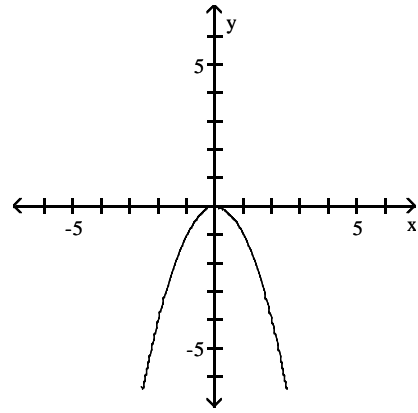

C)

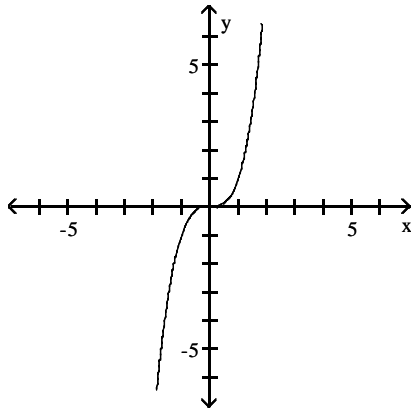

D)

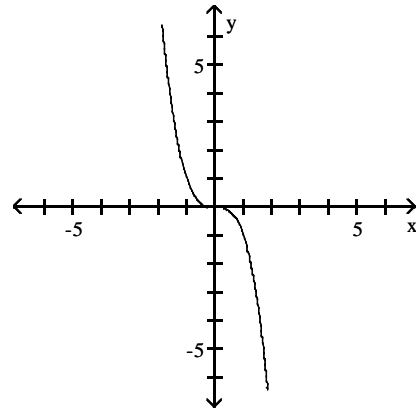

12) $f(x) = \sqrt{x}$

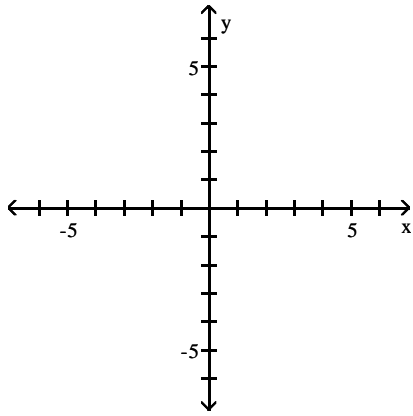

A)

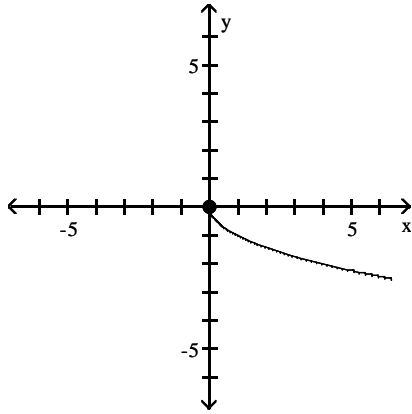

B)

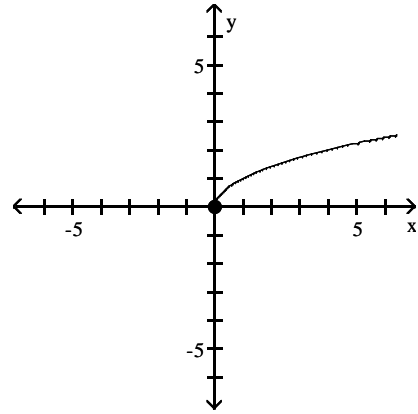

C)

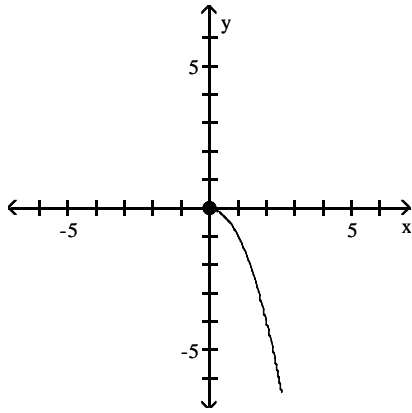

D)

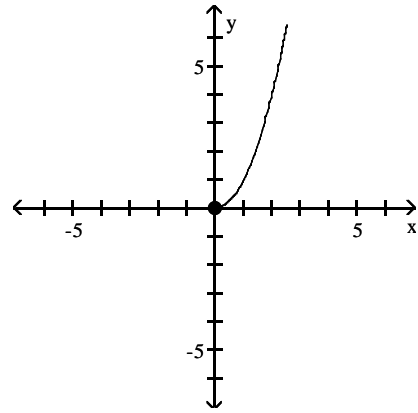

13) $f(x) = \frac{1}{x}$

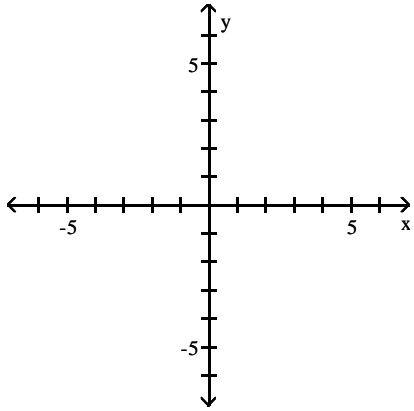

A)

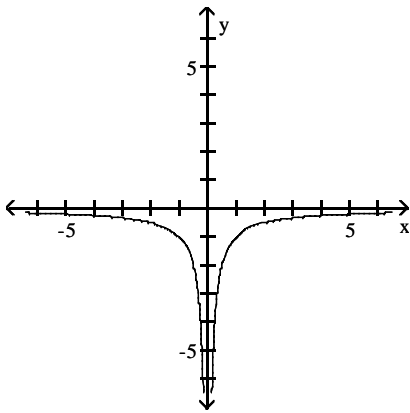

B)

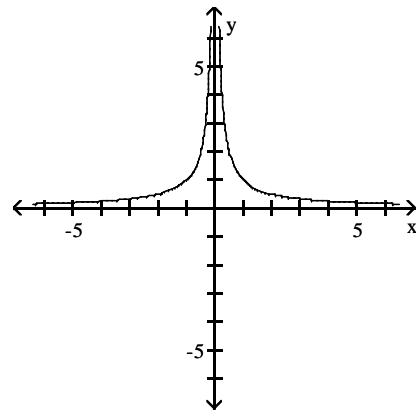

C)

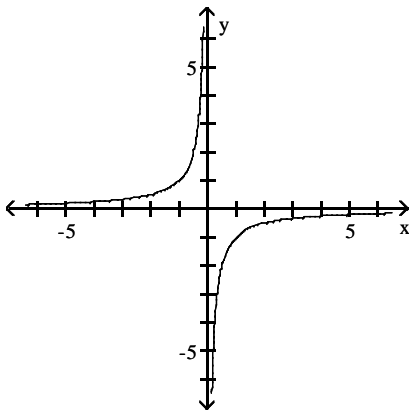

D)

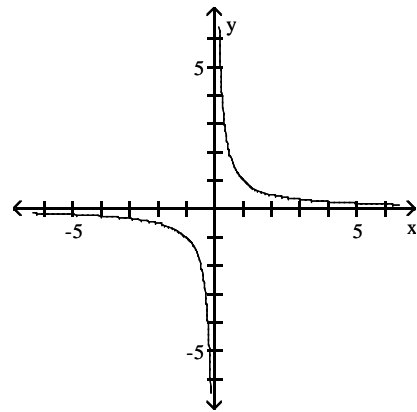

14) $f(x) = |x|$

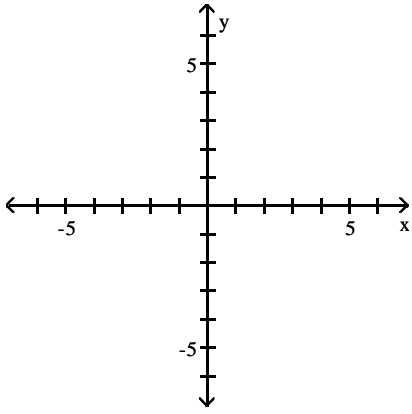

A)

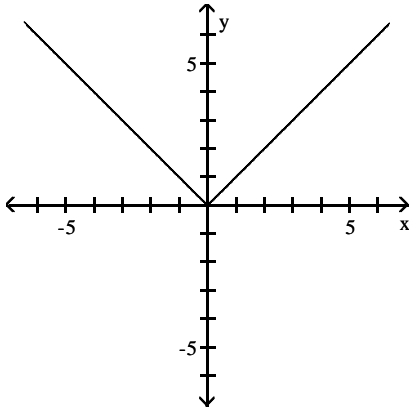

B)

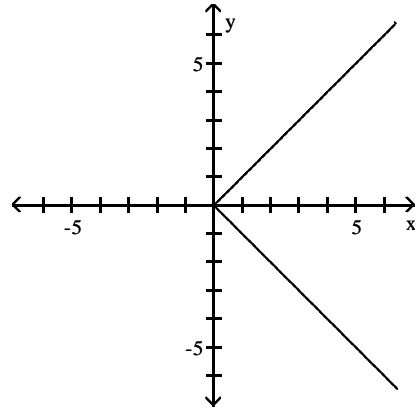

C)

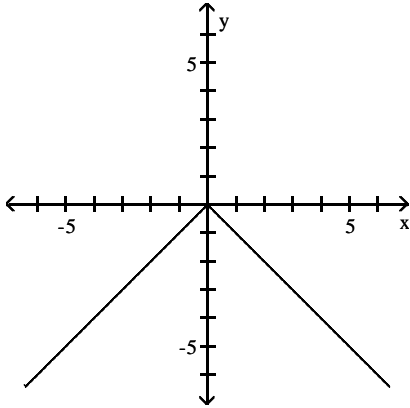

D)

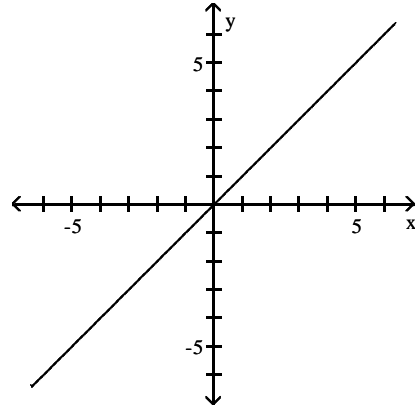

15) $f(x) = \sqrt[3]{x}$

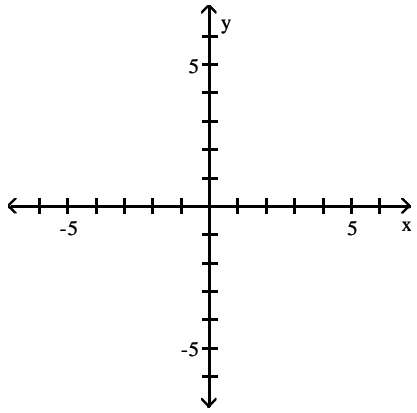

A)

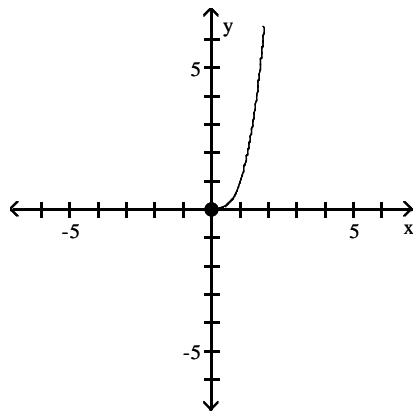

B)

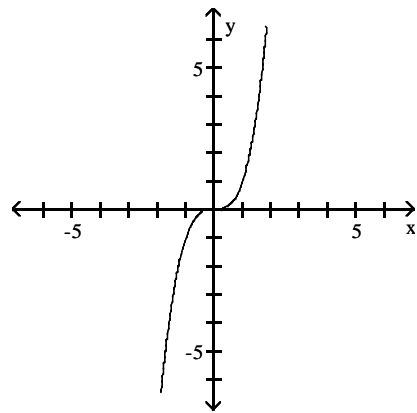

C)

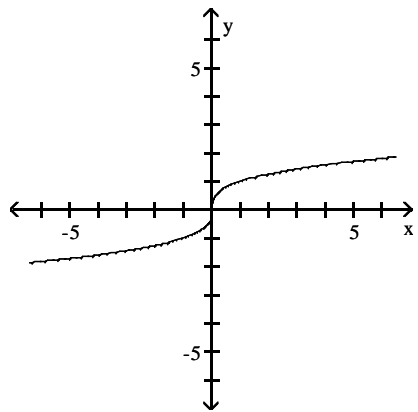

D)

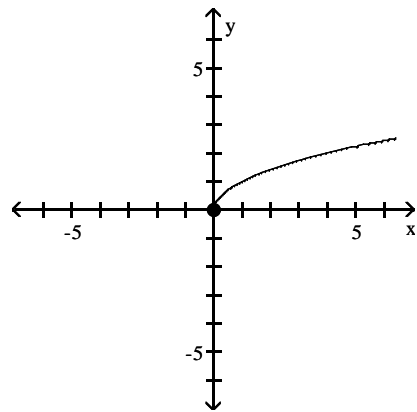

16) $f(x) = 4$

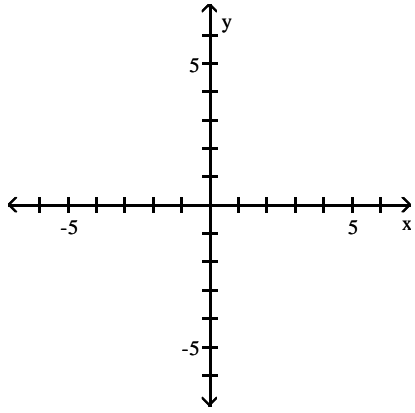

A)

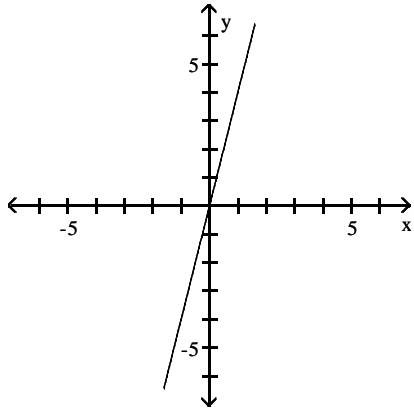

B)

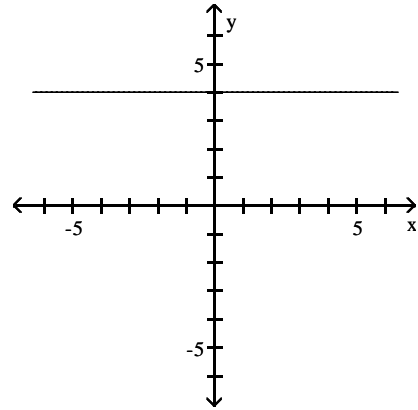

C)

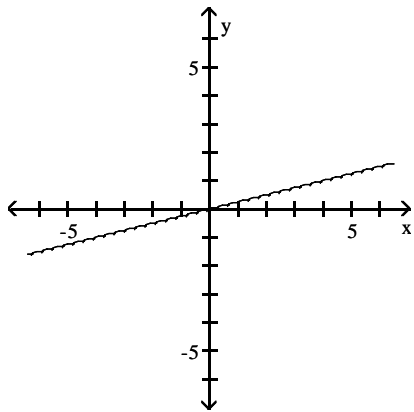

D)

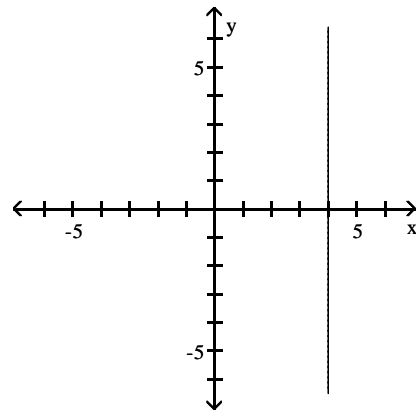

2 Graph Piecewise-defined Functions

MULTIPLE CHOICE. Choose the one alternative that best completes the statement or answers the question.

Graph the function.

$$1) f(x) = \begin{cases} x + 3 & \text{if } x < 1 \\ -2 & \text{if } x \geq 1 \end{cases}$$

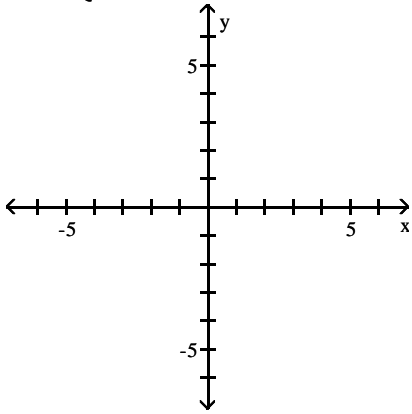

A)

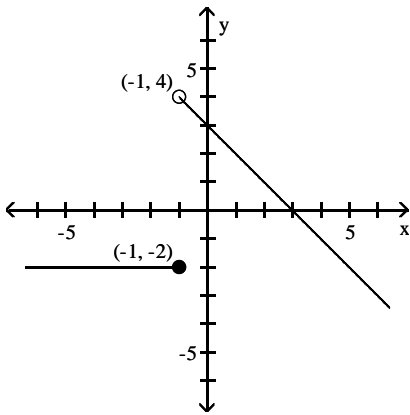

C)

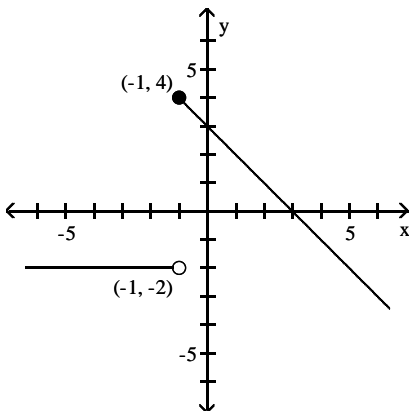

B)

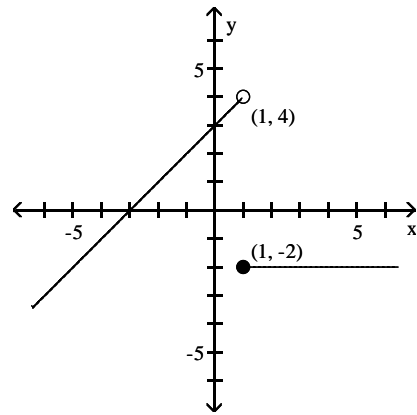

D)

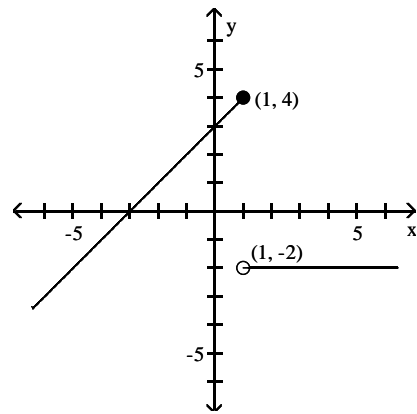

$$2) f(x) = \begin{cases} -x + 3 & \text{if } x < 2 \\ 2x - 3 & \text{if } x \geq 2 \end{cases}$$

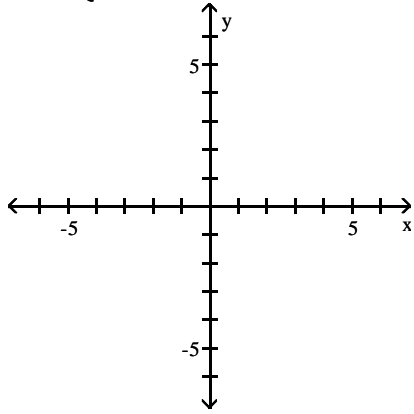

A)

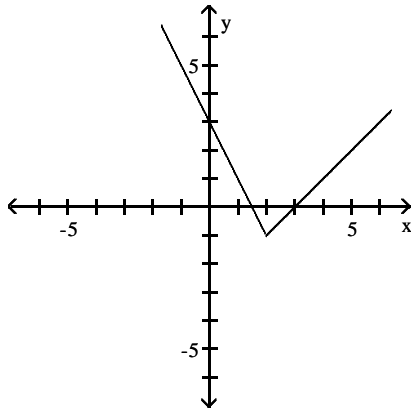

B)

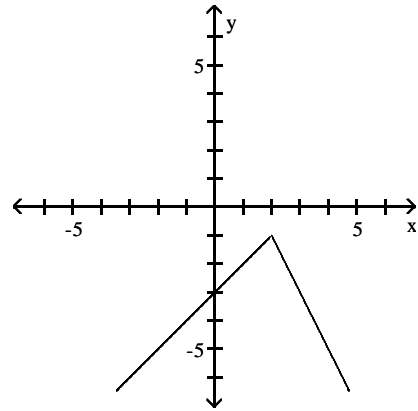

C)

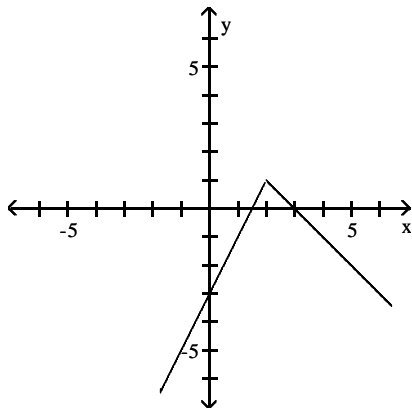

D)

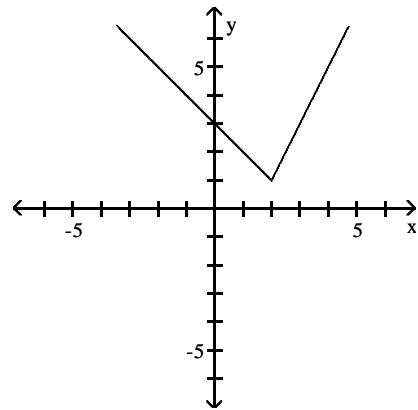

$$3) f(x) = \begin{cases} -x + 2 & \text{if } x < 0 \\ \sqrt{x} + 3 & \text{if } x \geq 0 \end{cases}$$

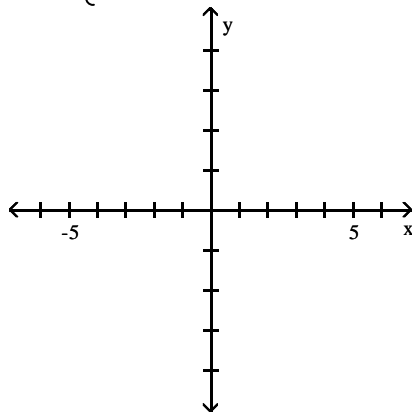

A)

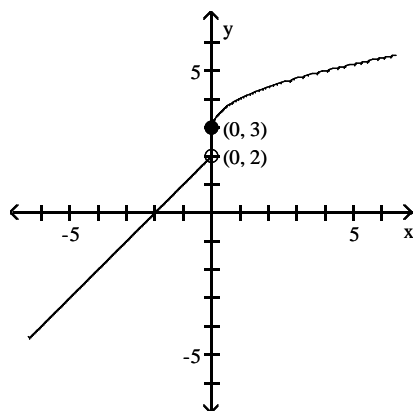

B)

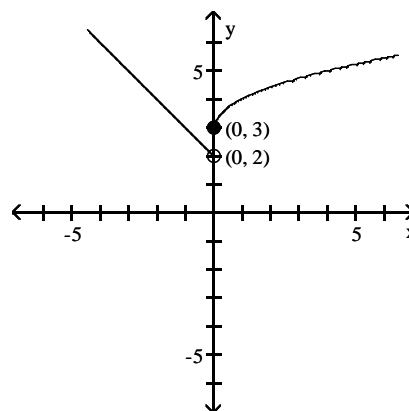

C)

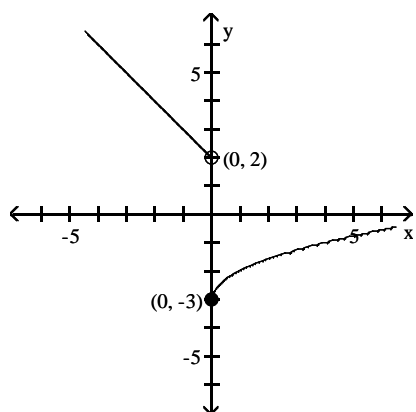

D)

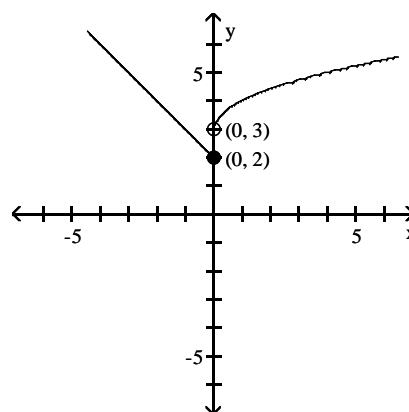

$$4) f(x) = \begin{cases} x + 1 & \text{if } -9 \leq x < 3 \\ -8 & \text{if } x = 3 \\ -x + 4 & \text{if } x > 3 \end{cases}$$

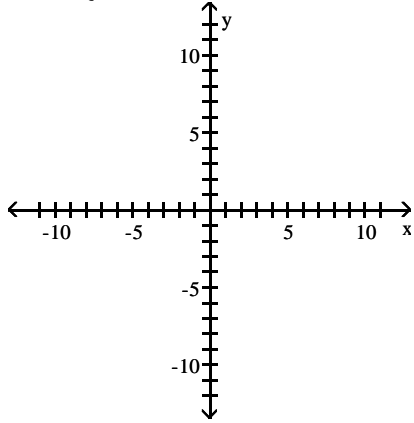

A)

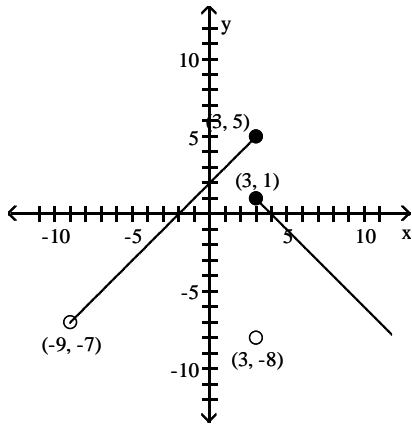

C)

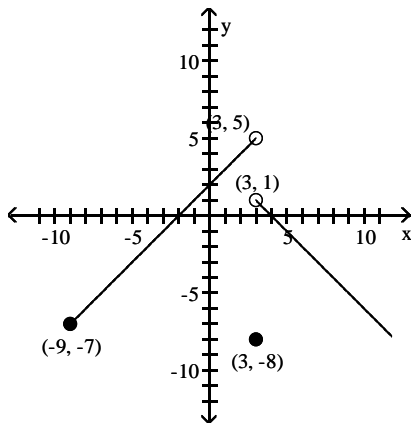

B)

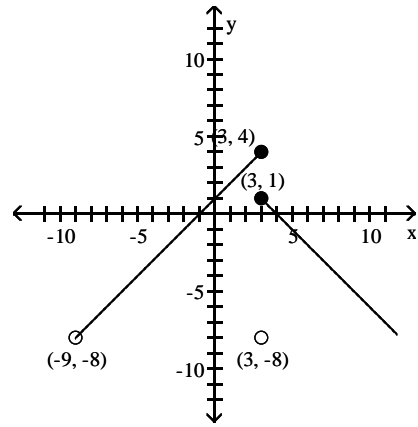

D)

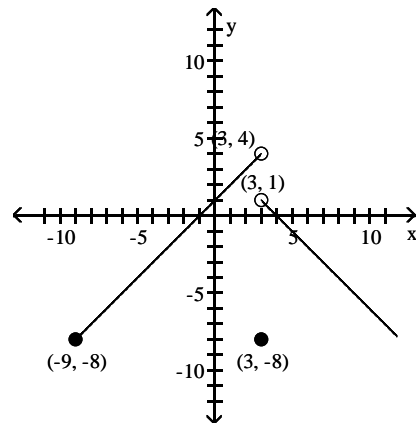

$$5) f(x) = \begin{cases} 1 & \text{if } -3 \leq x < 3 \\ |x| & \text{if } 3 \leq x < 5 \\ \sqrt{x} & \text{if } 5 \leq x \leq 14 \end{cases}$$

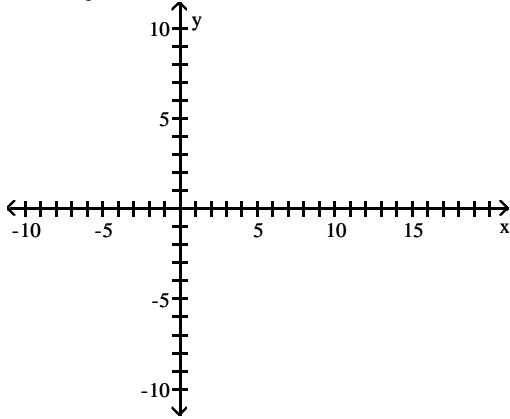

A)

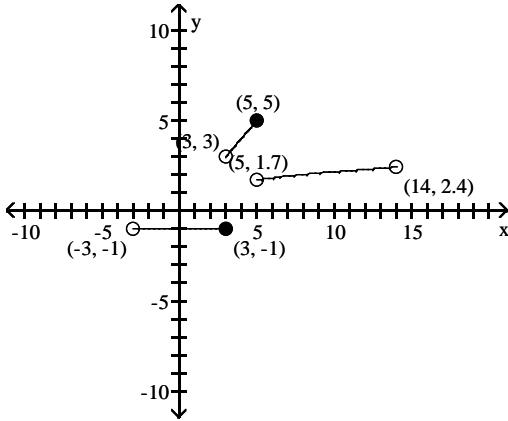

B)

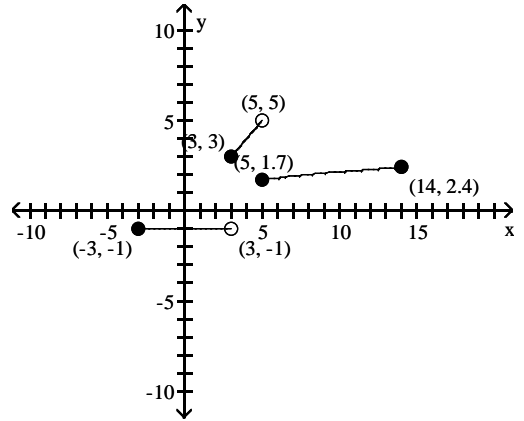

C)

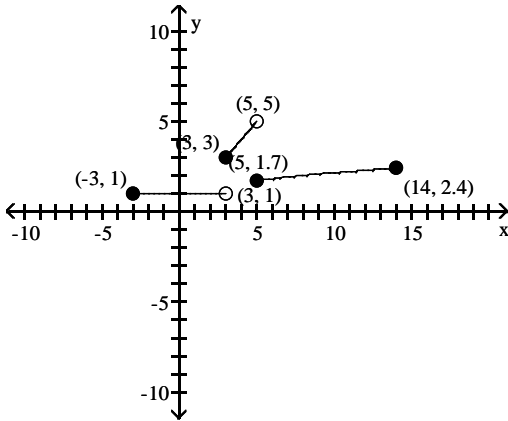

D)

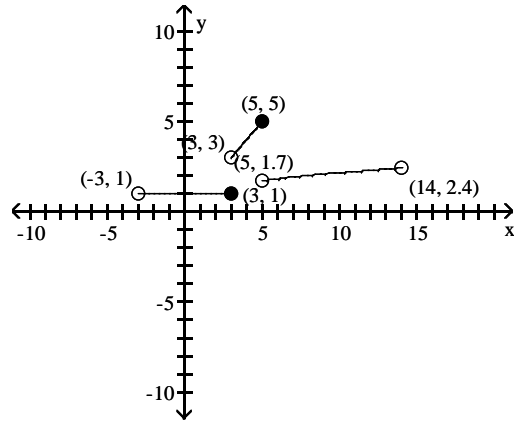

6) $f(x) = \text{int}(x) + 1$

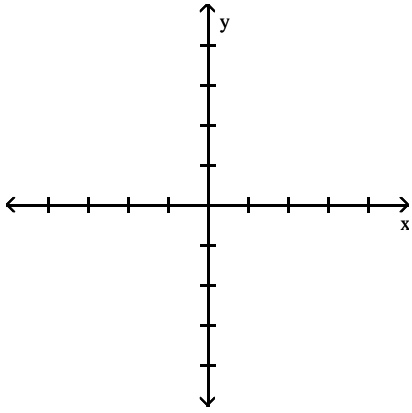

A)

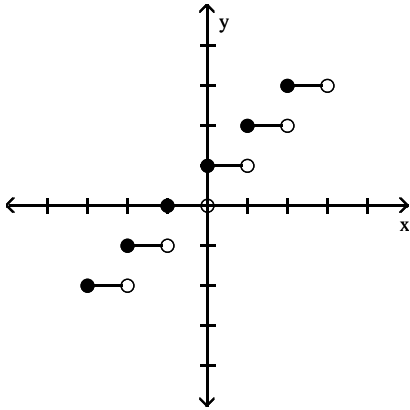

C)

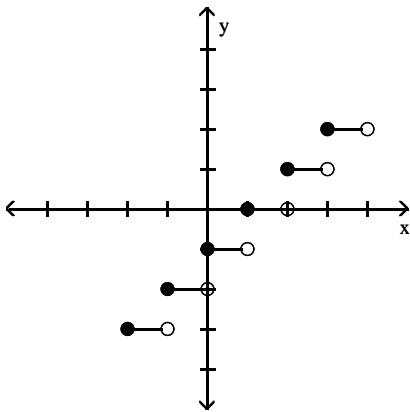

B)

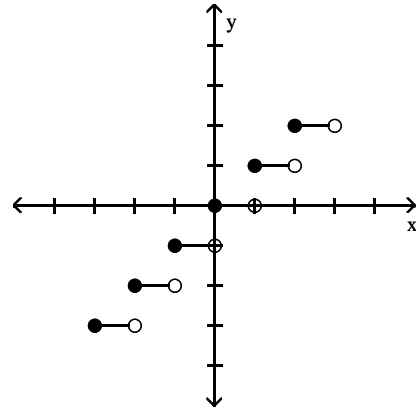

D)

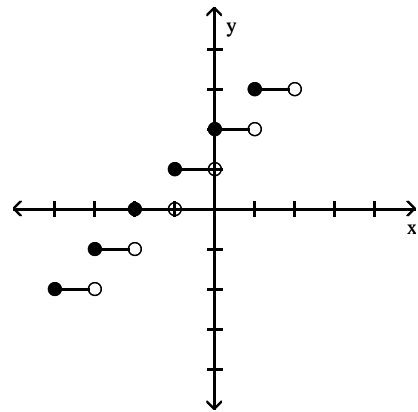

7) $f(x) = \text{int}(x)$

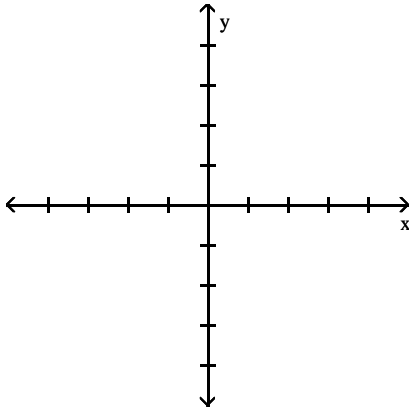

A)

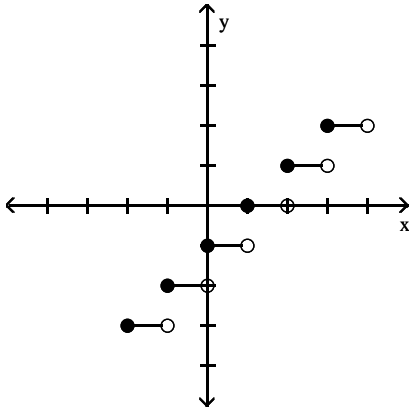

C)

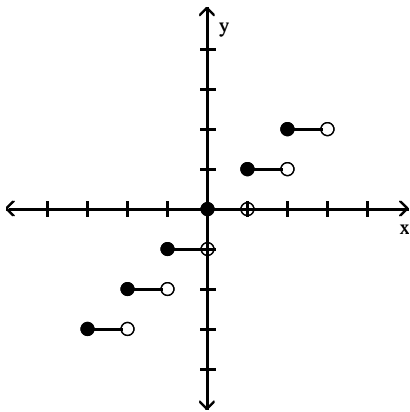

B)

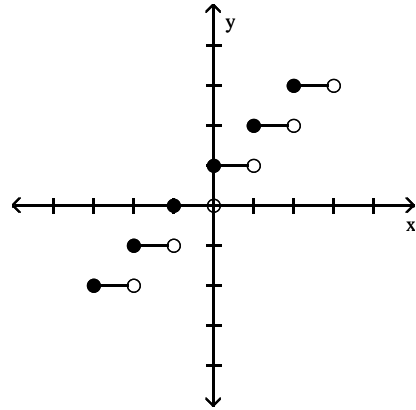

D)

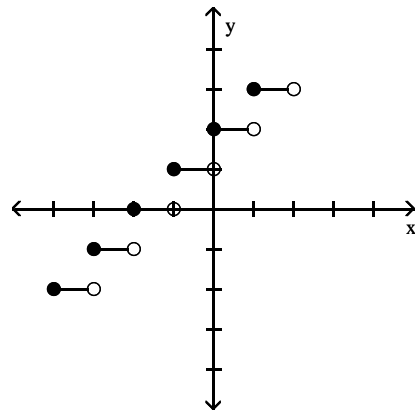

Find the domain of the function.

8) $f(x) = \begin{cases} 5x & \text{if } x \neq 0 \\ 5 & \text{if } x = 0 \end{cases}$

A) all real numbers

B) $\{0\}$

C) $\{x \mid x \neq 0\}$

D) $\{x \mid x \leq 0\}$

9) $f(x) = \begin{cases} 1 & \text{if } -8 \leq x < -3 \\ |x| & \text{if } -3 \leq x < 8 \\ \sqrt[3]{x} & \text{if } 8 \leq x \leq 23 \end{cases}$

A) $\{x \mid 8 \leq x \leq 23\}$

C) $\{x \mid x \geq -8\}$

B) $\{x \mid -8 \leq x < 8 \text{ or } 8 < x \leq 23\}$

D) $\{x \mid -8 \leq x \leq 23\}$

Locate any intercepts of the function.

$$10) f(x) = \begin{cases} -3x + 4 & \text{if } x < 1 \\ 4x - 3 & \text{if } x \geq 1 \end{cases}$$

A) (0, -3)

B) (0, -3), $\left\{\frac{4}{3}, 0\right\}$, $\left\{\frac{3}{4}, 0\right\}$

C) (0, 4), $\left\{\frac{4}{3}, 0\right\}$, $\left\{\frac{3}{4}, 0\right\}$

D) (0, 4)

$$11) f(x) = \begin{cases} 1 & \text{if } -6 \leq x < -5 \\ |x| & \text{if } -5 \leq x < 6 \\ \sqrt[3]{x} & \text{if } 6 \leq x \leq 32 \end{cases}$$

A) (0, 0), (1, 0)

B) (0, 0), (0, 1)

C) (0, 0)

D) none

Based on the graph, find the range of $y = f(x)$.

$$12) f(x) = \begin{cases} \frac{1}{5}x & \text{if } x \neq 0 \\ 8 & \text{if } x = 0 \end{cases}$$

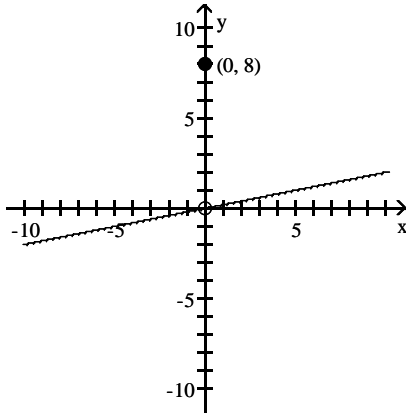

A) (-10, 10)

B) $(-\infty, \infty)$

C) $(-\infty, 0) \cup (0, \infty)$

D) $(-\infty, 0) \cup \{0\} \cup (0, \infty)$

$$13) f(x) = \begin{cases} 4 & \text{if } -4 \leq x < -2 \\ |x| & \text{if } -2 \leq x < 8 \\ \sqrt{x} & \text{if } 8 \leq x \leq 14 \end{cases}$$

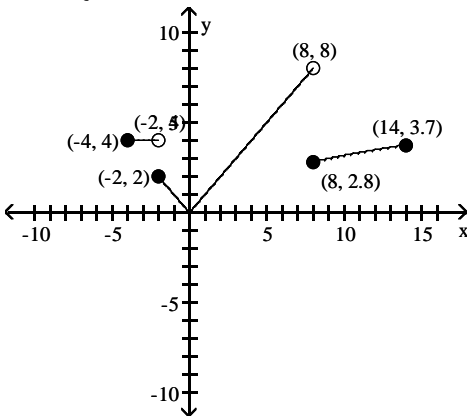

A) [0, 8]

B) $[0, \infty)$

C) [0, 8]

D) $[0, \sqrt{14}]$

The graph of a piecewise-defined function is given. Write a definition for the function.

14)

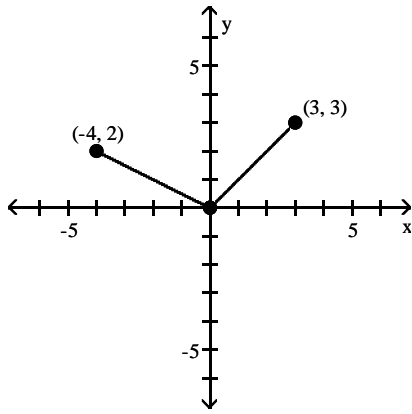

$$\text{A) } f(x) = \begin{cases} -\frac{1}{2}x & \text{if } -4 < x < 0 \\ x & \text{if } 0 < x < 3 \end{cases}$$

$$\text{B) } f(x) = \begin{cases} -\frac{1}{2}x & \text{if } -4 \leq x \leq 0 \\ x & \text{if } 0 < x \leq 3 \end{cases}$$

$$\text{C) } f(x) = \begin{cases} \frac{1}{2}x & \text{if } -4 < x < 0 \\ x & \text{if } 0 < x < 3 \end{cases}$$

$$\text{D) } f(x) = \begin{cases} -2x & \text{if } -4 \leq x \leq 0 \\ x & \text{if } 0 < x \leq 3 \end{cases}$$

15)

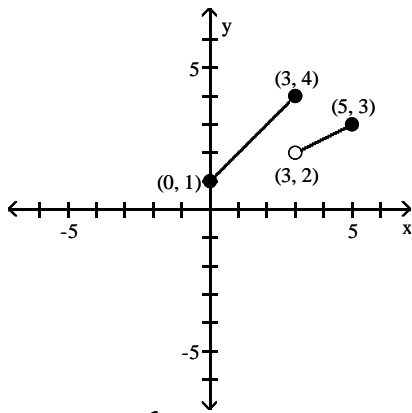

$$\text{A) } f(x) = \begin{cases} x + 1 & \text{if } 0 \leq x \leq 3 \\ \frac{1}{2}x & \text{if } 3 < x \leq 5 \end{cases}$$

$$\text{B) } f(x) = \begin{cases} x + 1 & \text{if } 0 \leq x \leq 3 \\ \frac{1}{2}x - \frac{1}{2} & \text{if } 3 < x \leq 5 \end{cases}$$

$$\text{C) } f(x) = \begin{cases} x + 1 & \text{if } 0 \leq x \leq 3 \\ \frac{1}{2}x + 2 & \text{if } 3 < x \leq 5 \end{cases}$$

$$\text{D) } f(x) = \begin{cases} x + 1 & \text{if } 0 \leq x \leq 3 \\ \frac{1}{2}x + \frac{1}{2} & \text{if } 3 < x \leq 5 \end{cases}$$

16)

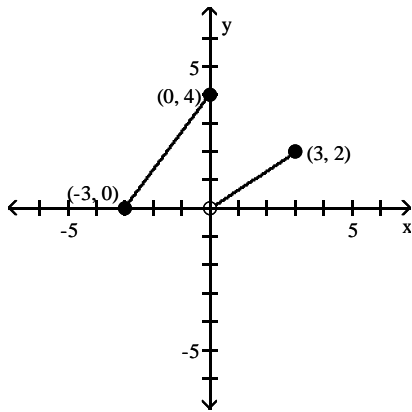

$$\text{A) } f(x) = \begin{cases} \frac{4}{3}x + 4 & \text{if } -3 \leq x \leq 0 \\ \frac{2}{3}x & \text{if } 0 < x \leq 3 \end{cases}$$

$$\text{B) } f(x) = \begin{cases} \frac{4}{3}x - 4 & \text{if } -3 \leq x \leq 0 \\ \frac{2}{3}x & \text{if } 0 \leq x \leq 3 \end{cases}$$

$$\text{C) } f(x) = \begin{cases} \frac{4}{3}x + 4 & \text{if } -3 \leq x \leq 0 \\ \frac{2}{3}x + 2 & \text{if } 0 < x \leq 3 \end{cases}$$

$$\text{D) } f(x) = \begin{cases} \frac{3}{4}x + 4 & \text{if } -3 \leq x \leq 0 \\ \frac{3}{2}x & \text{if } 0 < x \leq 3 \end{cases}$$

17)

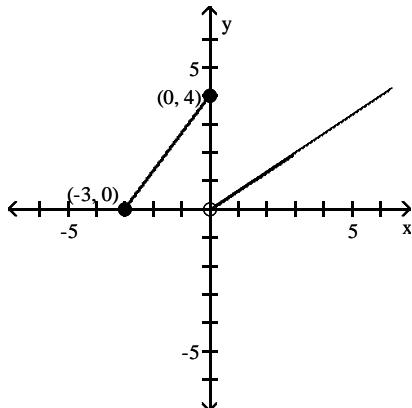

$$\text{A) } f(x) = \begin{cases} \frac{3}{4}x + 4 & \text{if } -3 \leq x \leq 0 \\ \frac{3}{2}x & \text{if } x > 0 \end{cases}$$

$$\text{B) } f(x) = \begin{cases} \frac{4}{3}x + 4 & \text{if } -3 \leq x \leq 0 \\ \frac{2}{3}x & \text{if } x > 0 \end{cases}$$

$$\text{C) } f(x) = \begin{cases} \frac{3}{4}x + 4 & \text{if } -3 \leq x \leq 0 \\ \frac{3}{2}x & \text{if } x \geq 0 \end{cases}$$

$$\text{D) } f(x) = \begin{cases} \frac{4}{3}x + 4 & \text{if } -3 \leq x \leq 0 \\ \frac{2}{3}x & \text{if } 0 < x \leq 3 \end{cases}$$

Solve the problem.

18) If $f(x) = \text{int}(4x)$, find $f(-1.4)$.

A) -1

B) -6

C) -5

D) -2

SHORT ANSWER. Write the word or phrase that best completes each statement or answers the question.

19) A gas company has the following rate schedule for natural gas usage in single-family residences:

Monthly service charge	\$8.80
Per therm service charge	
1st 25 therms	\$0.6686/therm
Over 25 therms	\$0.85870/therm

What is the charge for using 25 therms in one month?

What is the charge for using 45 therms in one month?

Construct a function that gives the monthly charge C for x therms of gas.

20) An electric company has the following rate schedule for electricity usage in single-family residences:

Monthly service charge	\$4.93
Per kilowatt service charge	
1st 300 kilowatts	\$0.11589/kW
Over 300 kilowatts	\$0.13321/kW

What is the charge for using 300 kilowatts in one month?

What is the charge for using 375 kilowatts in one month?

Construct a function that gives the monthly charge C for x kilowatts of electricity.

21) One Internet service provider has the following rate schedule for high-speed Internet service:

Monthly service charge	\$18.00
1st 50 hours of use	free
Next 50 hours of use	\$0.25/hour
Over 100 hours of use	\$1.00/hour

What is the charge for 50 hours of high-speed Internet use in one month?

What is the charge for 75 hours of high-speed Internet use in one month?

What is the charge for 135 hours of high-speed Internet use in one month?

22) The wind chill factor represents the equivalent air temperature at a standard wind speed that would produce the same heat loss as the given temperature and wind speed. One formula for computing the equivalent temperature is

$$W(t) = \begin{cases} t & \text{if } 0 \leq v < 1.79 \\ 33 - \frac{(10.45 + 10\sqrt{v} - v)(33 - t)}{22.04} & \text{if } 1.79 \leq v < 20 \\ 33 - 1.5958(33 - t) & \text{if } v \geq 20 \end{cases}$$

where v represents the wind speed (in meters per second) and t represents the air temperature ($^{\circ}\text{C}$). Compute the wind chill for an air temperature of 15°C and a wind speed of 12 meters per second. (Round the answer to one decimal place.)

23) A cellular phone plan had the following schedule of charges:

Basic service, including 100 minutes of calls	\$20.00 per month
2nd 100 minutes of calls	\$0.075 per minute
Additional minutes of calls	\$0.10 per minute

What is the charge for 200 minutes of calls in one month?

What is the charge for 250 minutes of calls in one month?

Construct a function that relates the monthly charge C for x minutes of calls.

2.5 Graphing Techniques: Transformations

1 Graph Functions Using Vertical and Horizontal Shifts

MULTIPLE CHOICE. Choose the one alternative that best completes the statement or answers the question.

Match the correct function to the graph.

1)

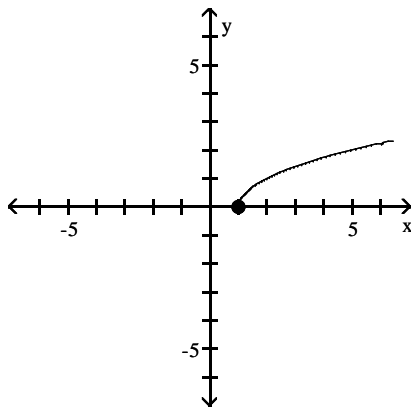

A) $y = x - 1$

B) $y = \sqrt{x}$

C) $y = \sqrt{x + 1}$

D) $y = \sqrt{x - 1}$

2)

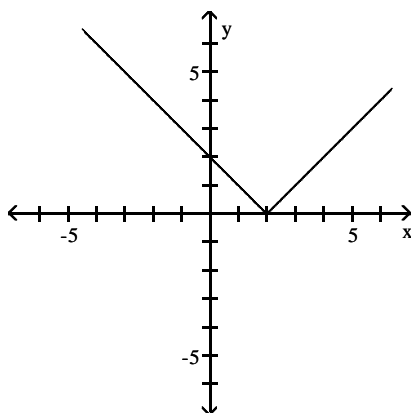

A) $y = |x + 2|$

B) $y = |1 - x|$

C) $y = x - 2$

D) $y = |2 - x|$

Write the equation of a function that has the given characteristics.

3) The graph of $y = x^2$, shifted 7 units downward

A) $y = 7x^2$

B) $y = \frac{x^2}{7}$

C) $y = x^2 - 7$

D) $y = x^2 + 7$

4) The graph of $y = |x|$, shifted 5 units to the right

A) $y = |x + 5|$

B) $y = |x| + 5$

C) $y = |x| - 5$

D) $y = |x - 5|$

- 5) The graph of $y = |x|$, shifted 8 units upward
 A) $y = |x + 8|$ B) $y = |x - 8|$ C) $y = |x| + 8$ D) $y = |x| - 8$
- 6) The graph of $y = \sqrt{x}$, shifted 7 units to the right
 A) $y = \sqrt{x + 7}$ B) $y = \sqrt{x - 7}$ C) $y = \sqrt{x} + 7$ D) $y = \sqrt{x - 7}$
- 7) The graph of $y = \sqrt{x}$, shifted 7 units to the left
 A) $y = \sqrt{x + 7}$ B) $y = \sqrt{x - 7}$ C) $y = \sqrt{x} - 7$ D) $y = \sqrt{x} + 7$
- 8) The graph of $y = \sqrt{x}$, shifted 6 units upward
 A) $y = \sqrt{x} + 6$ B) $y = \sqrt{x - 6}$ C) $y = \sqrt{x} - 6$ D) $y = \sqrt{x + 6}$
- 9) The graph of $y = \sqrt{x}$, shifted 4 units downward
 A) $y = \sqrt{x} + 4$ B) $y = \sqrt{x} - 4$ C) $y = \sqrt{x - 4}$ D) $y = \sqrt{x + 4}$

Suppose the point (2, 4) is on the graph of $y = f(x)$. Find a point on the graph of the given function.

- 10) $y = f(x + 2)$
 A) (2, 2) B) (4, 4) C) (0, 4) D) (2, 6)
- 11) $y = f(x) + 2$
 A) (0, 4) B) (4, 4) C) (2, 6) D) (2, -2)

Solve the problem.

- 12) Suppose that the x-intercepts of the graph of $y = f(x)$ are 3 and 5. What are the x-intercepts of $y = f(x + 2)$?
 A) 6 and 10 B) 5 and 7 C) 1 and 3 D) 3 and 7
- 13) Suppose that the x-intercepts of the graph of $y = f(x)$ are 4 and 5. What are the x-intercepts of $y = f(x - 8)$?
 A) 4 and -3 B) -4 and -3 C) 32 and 40 D) 12 and 13
- 14) Suppose that the function $y = f(x)$ is increasing on the interval (4, 7). Over what interval is the graph of $y = f(x + 5)$ increasing?
 A) (9, 12) B) (4, 7) C) (-1, 2) D) (20, 35)
- 15) Suppose that the function $y = f(x)$ is increasing on the interval (2, 9). Over what interval is the graph of $y = f(x - 7)$ increasing?
 A) (9, 16) B) (2, 9) C) (14, 63) D) (-5, 2)

Graph the function by starting with the graph of the basic function and then using the techniques of shifting, compressing, stretching, and/or reflecting.

16) $f(x) = x^2 + 2$

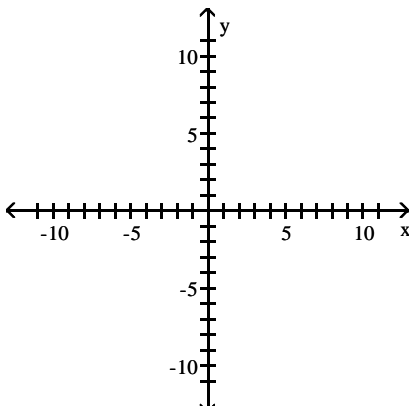

A)

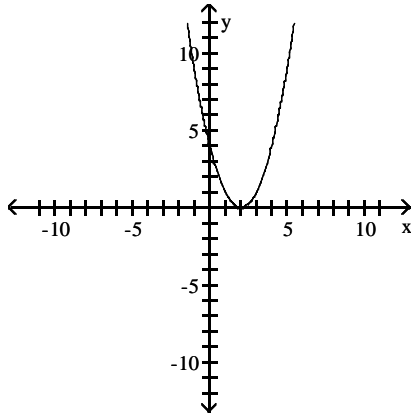

B)

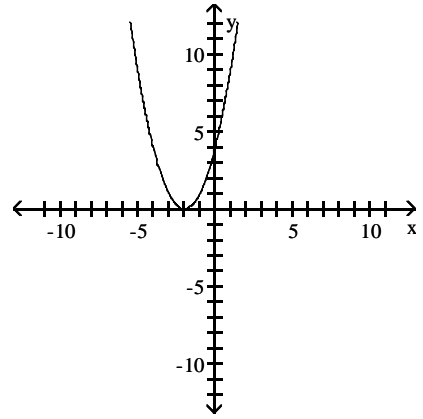

C)

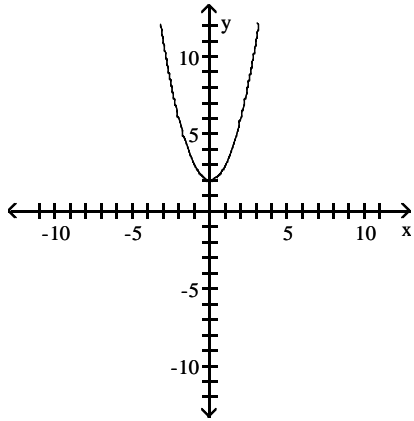

D)

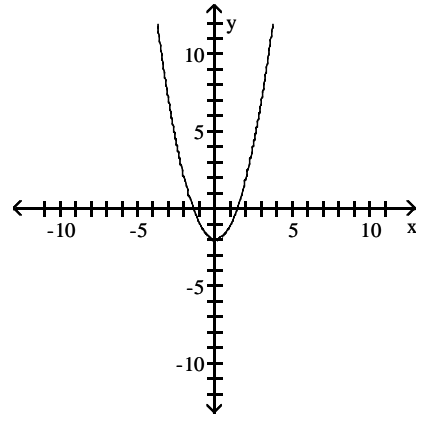

17) $f(x) = (x - 5)^2$

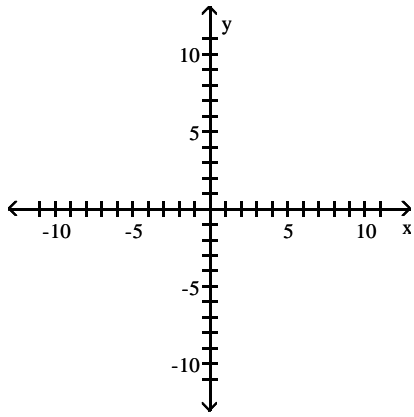

A)

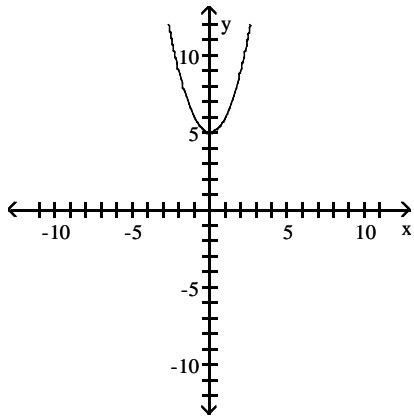

B)

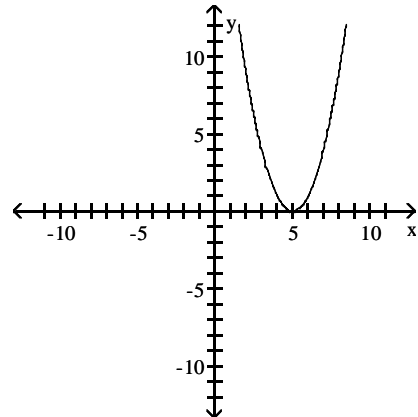

C)

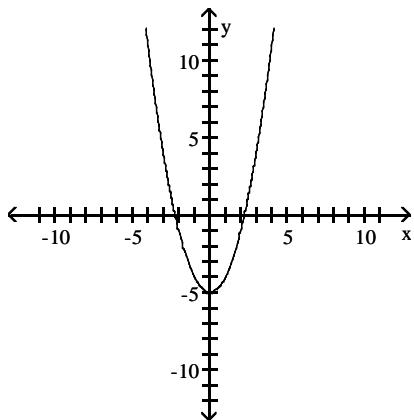

D)

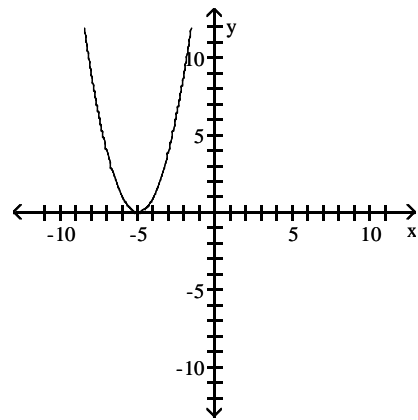

18) $f(x) = (x + 3)^2 + 3$

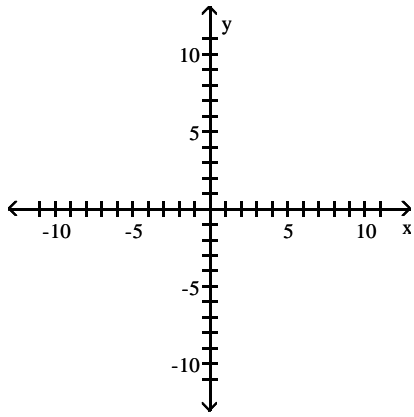

A)

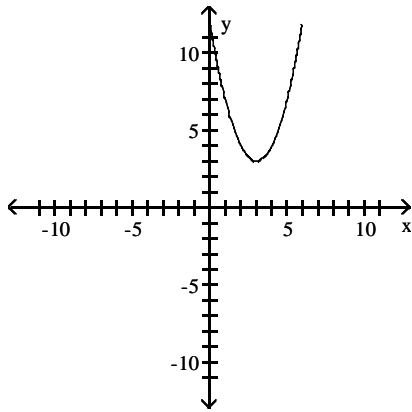

B)

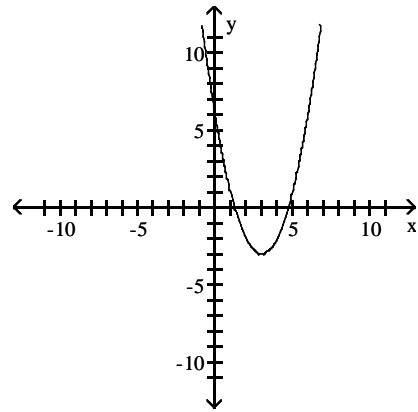

C)

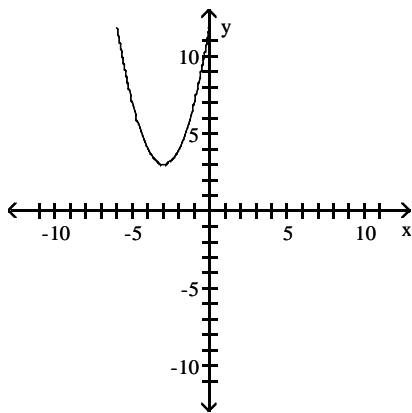

D)

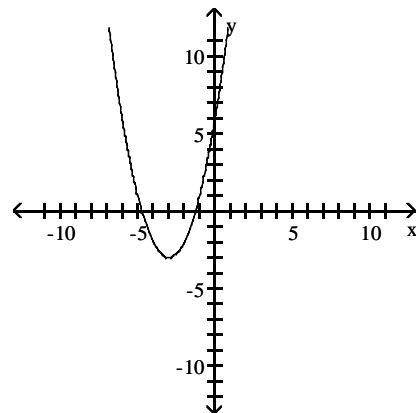

19) $f(x) = x^3 + 5$

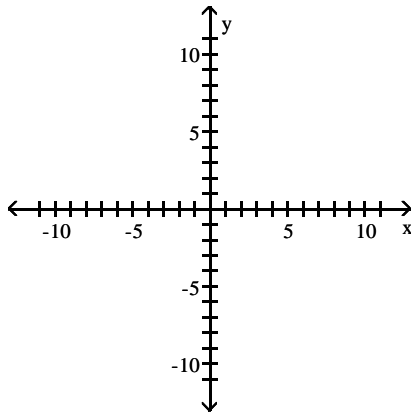

A)

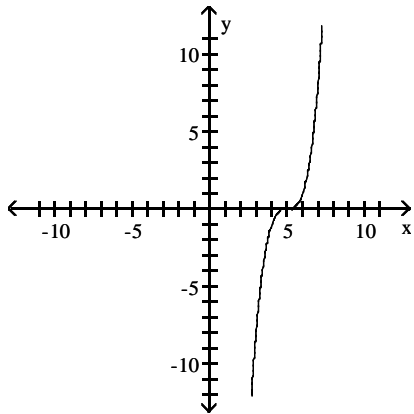

B)

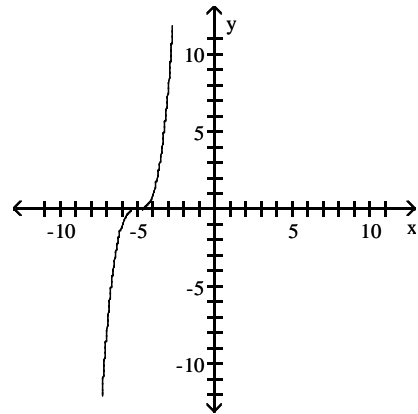

C)

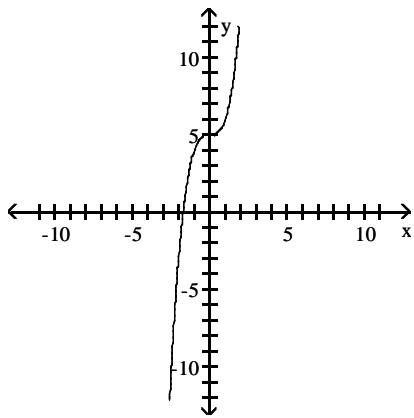

D)

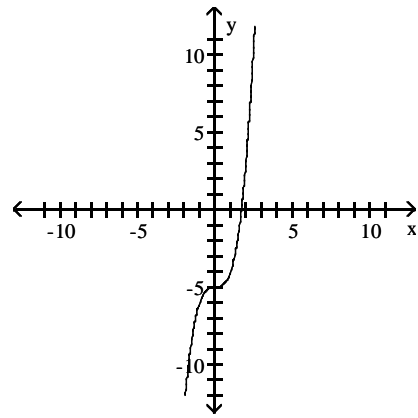

20) $f(x) = (x - 4)^3$

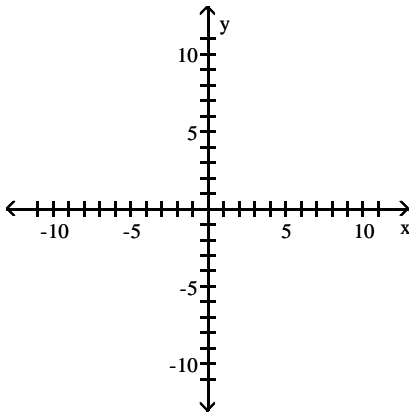

A)

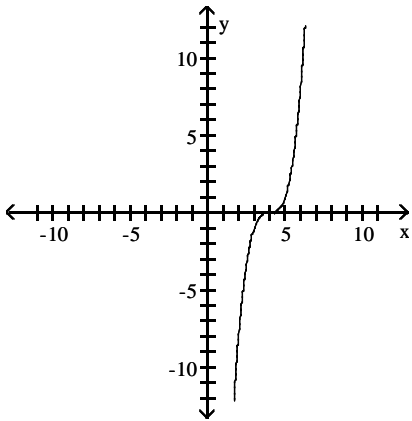

B)

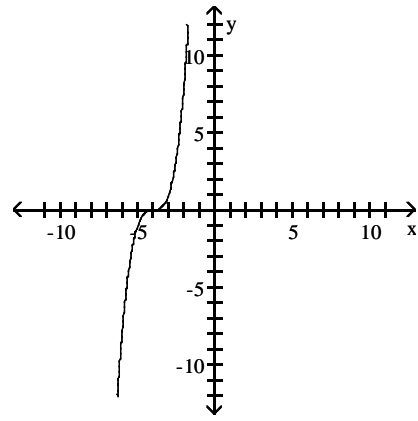

C)

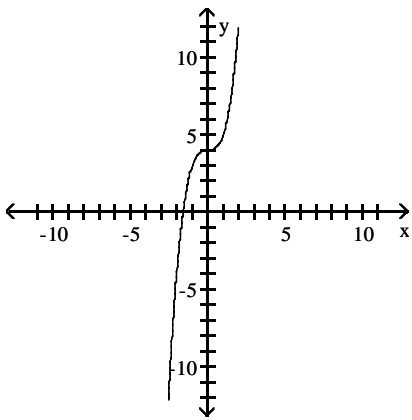

D)

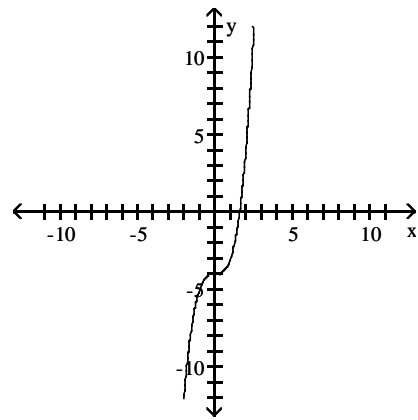

21) $f(x) = (x - 7)^3 - 6$

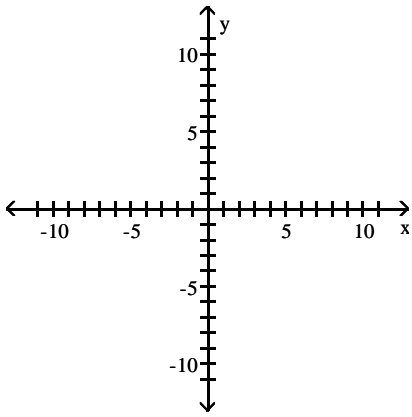

A)

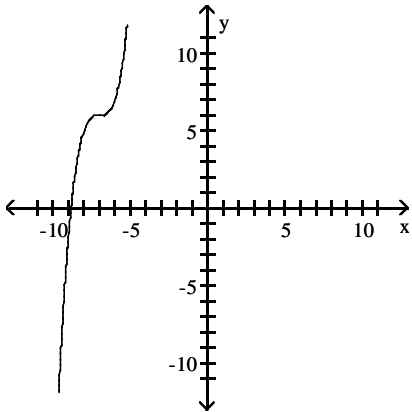

B)

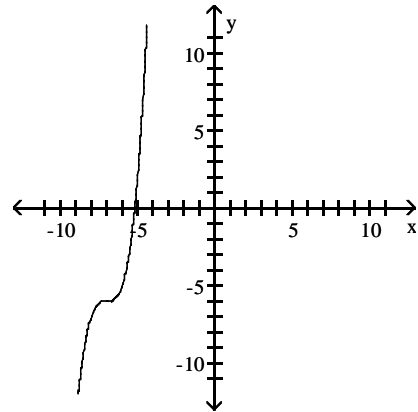

C)

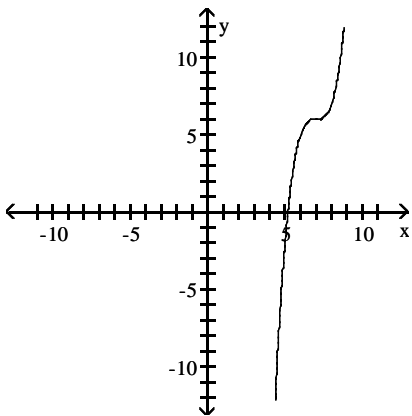

D)

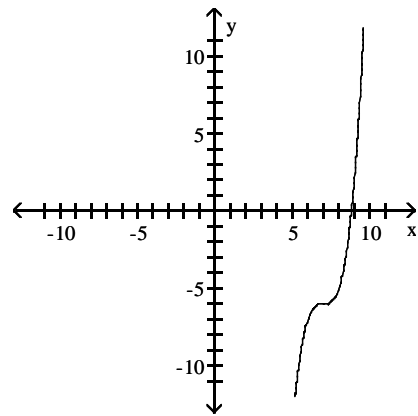

22) $f(x) = \sqrt{x} - 1$

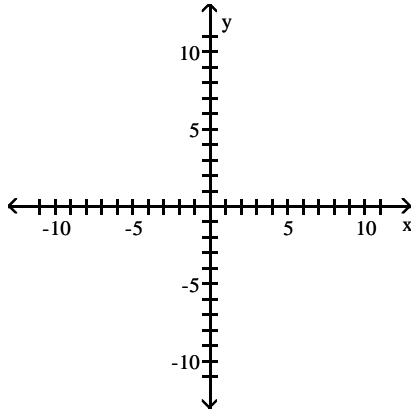

A)

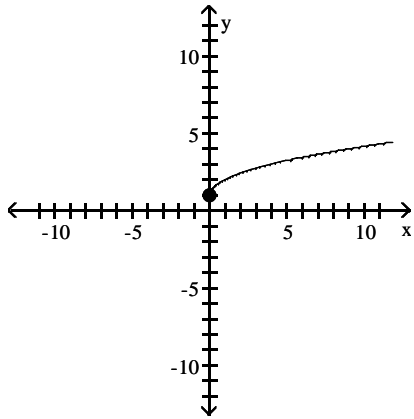

B)

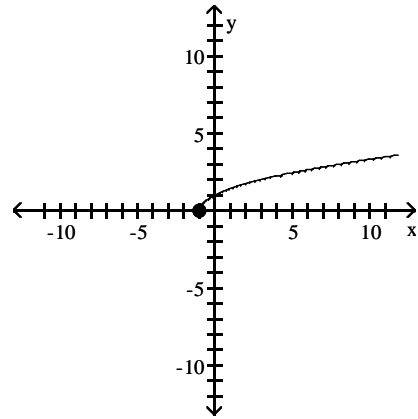

C)

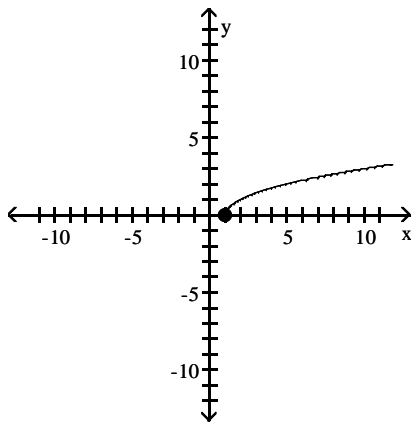

D)

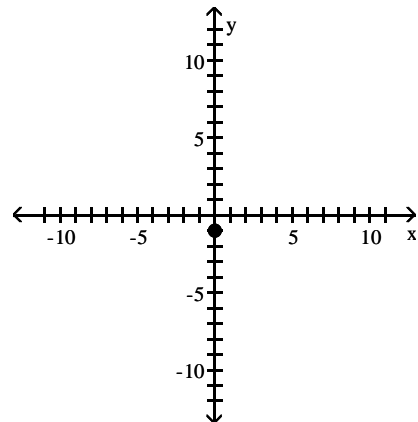

23) $f(x) = \sqrt{x - 4}$

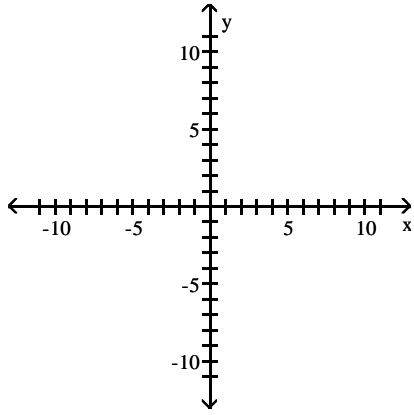

A)

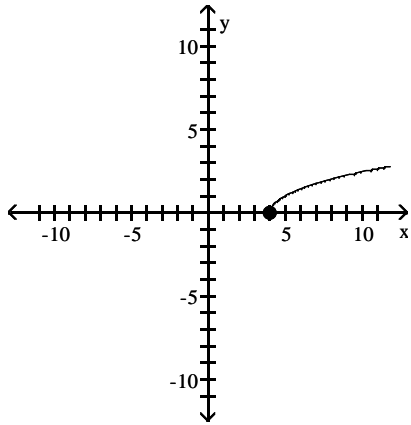

B)

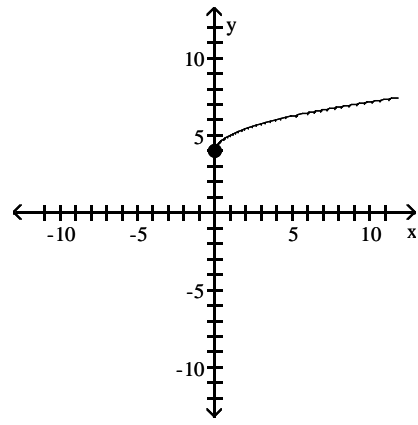

C)

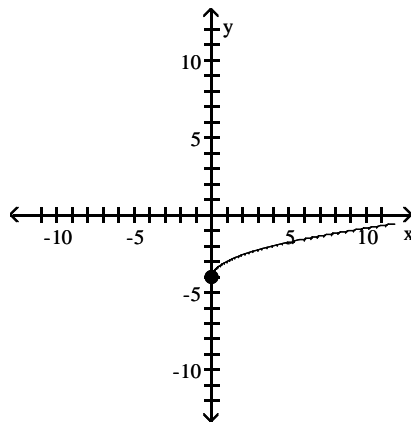

D)

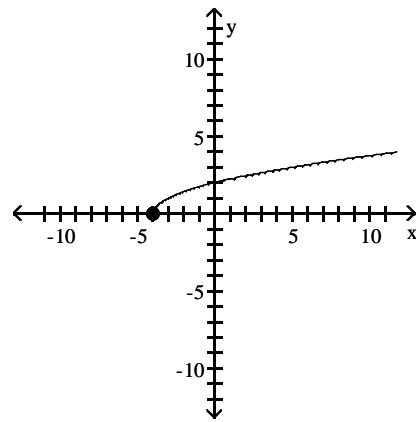

24) $f(x) = \sqrt{x+5} - 2$

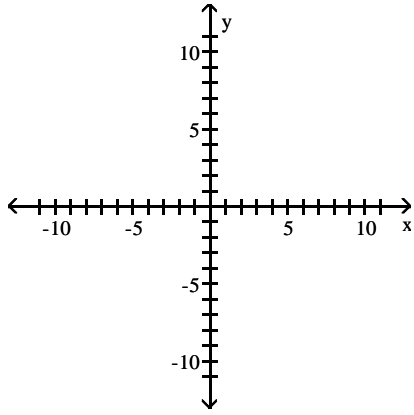

A)

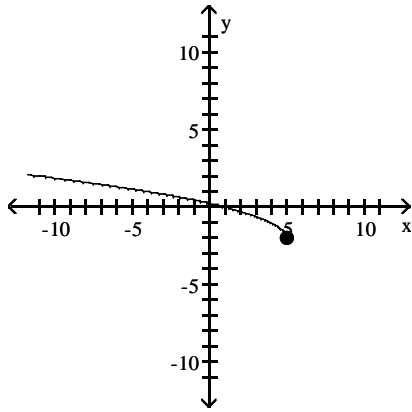

B)

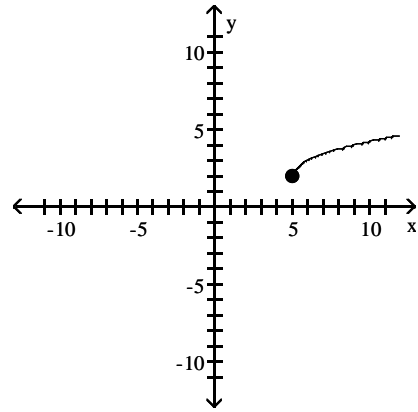

C)

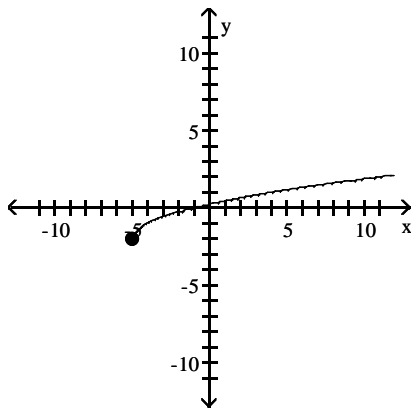

D)

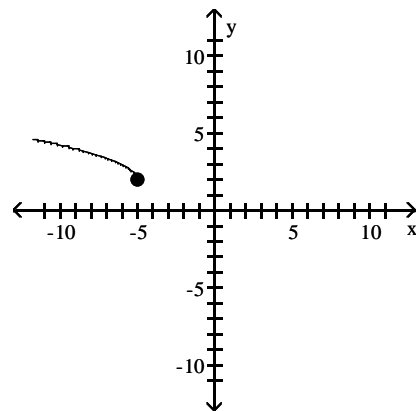

25) $f(x) = \sqrt{x - 5} + 4$

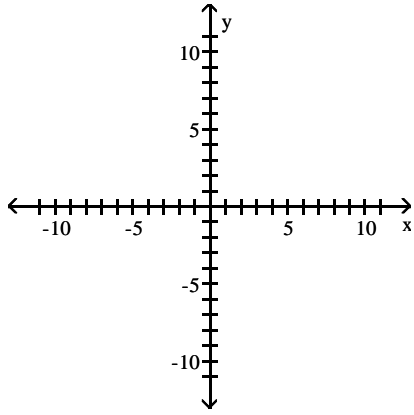

A)

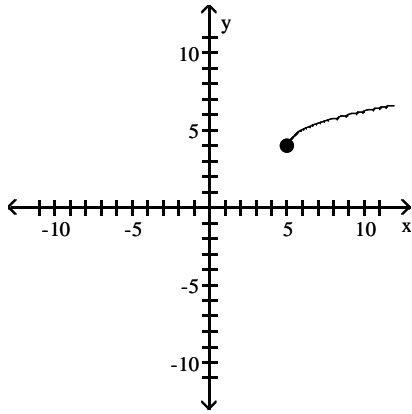

B)

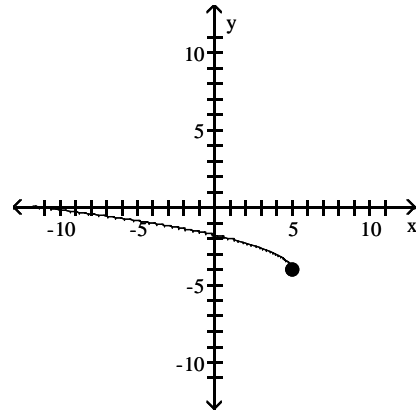

C)

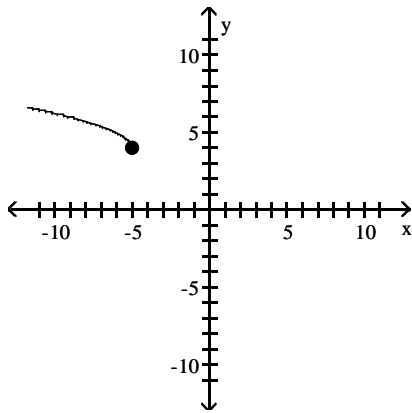

D)

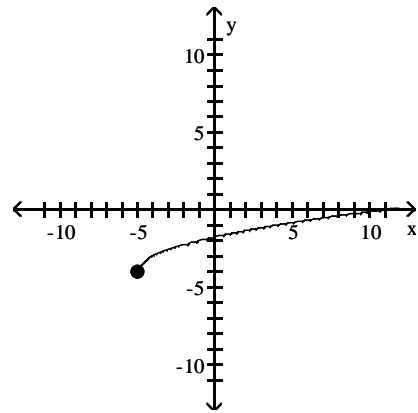

26) $f(x) = |x| - 4$

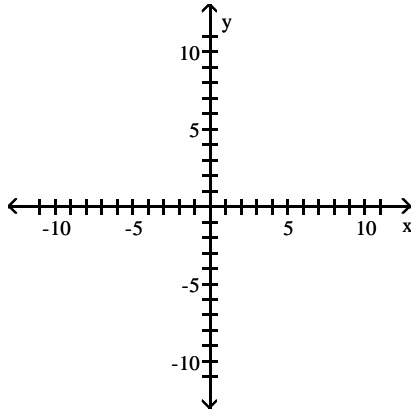

A)

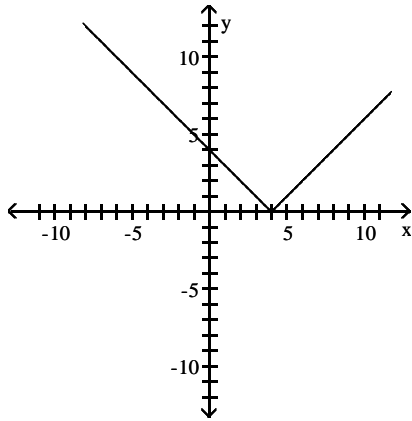

B)

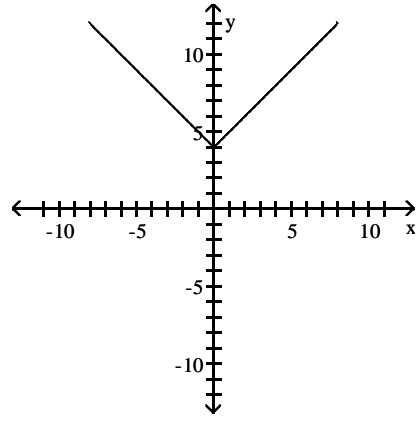

C)

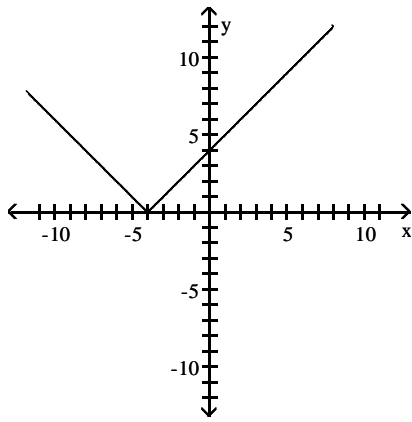

D)

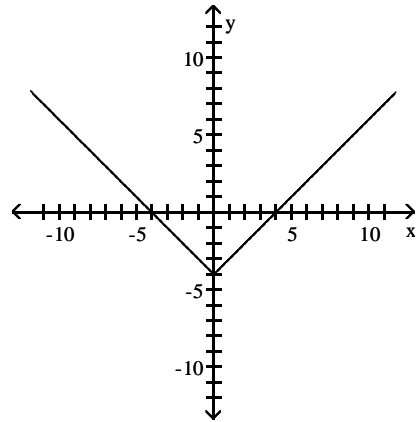

27) $f(x) = |x + 3|$

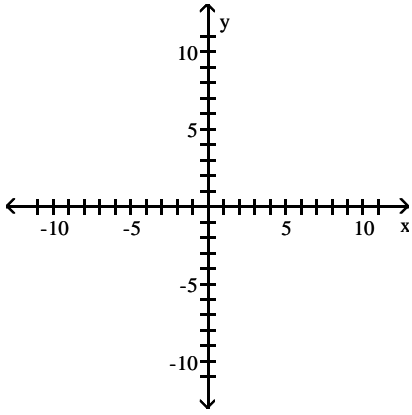

A)

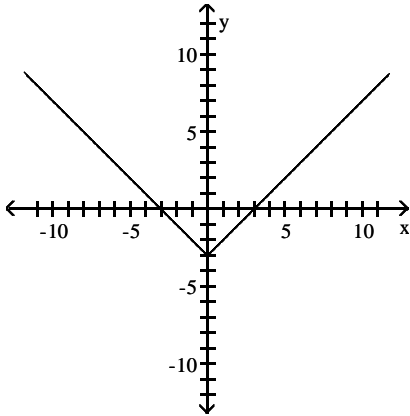

B)

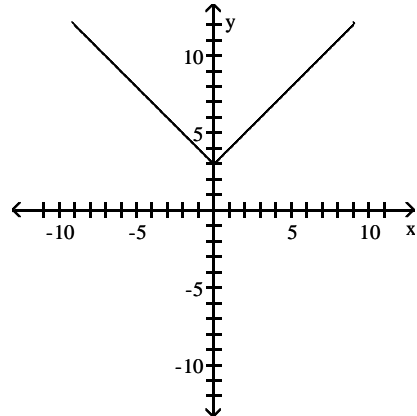

C)

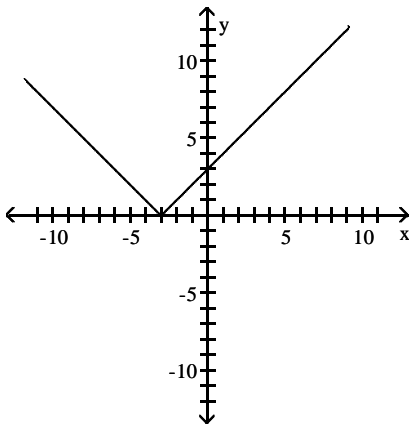

D)

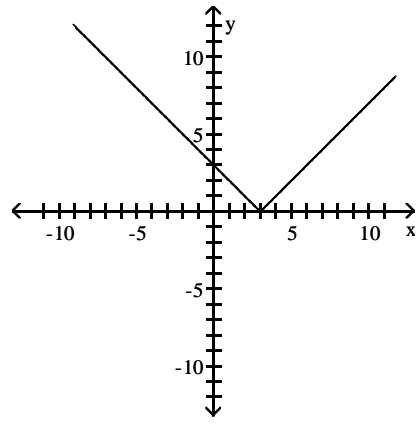

28) $f(x) = |x + 5| - 5$

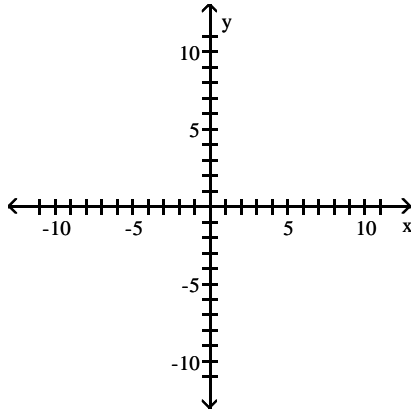

A)

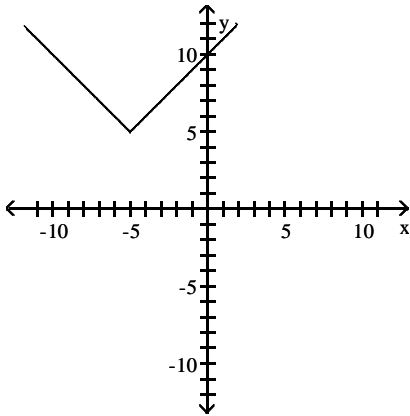

B)

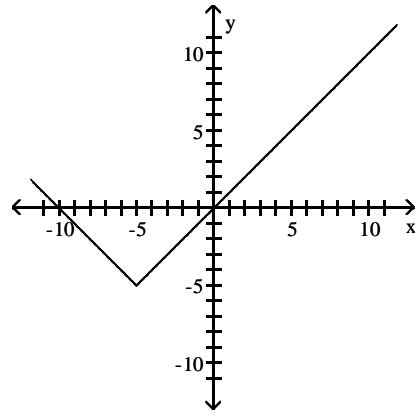

C)

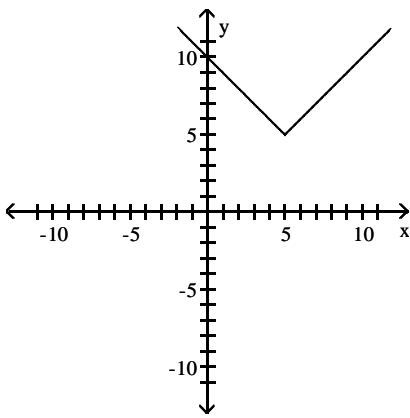

D)

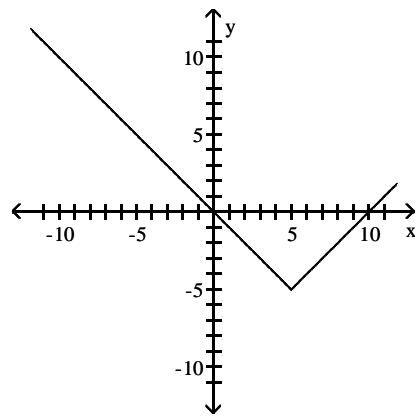

29) $f(x) = \frac{1}{x} + 1$

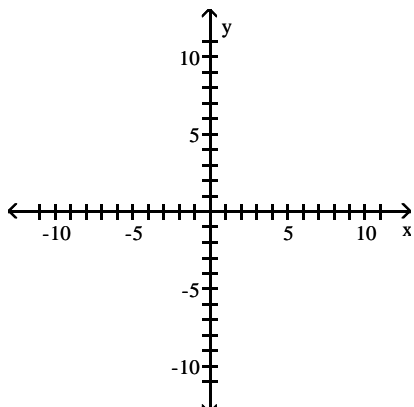

A)

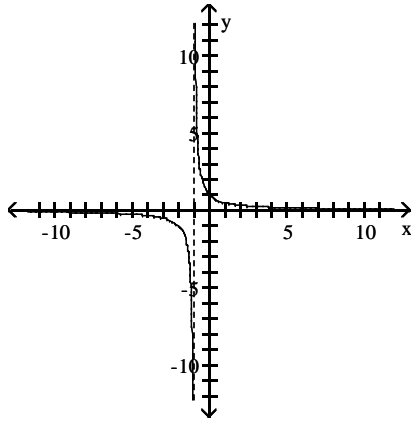

B)

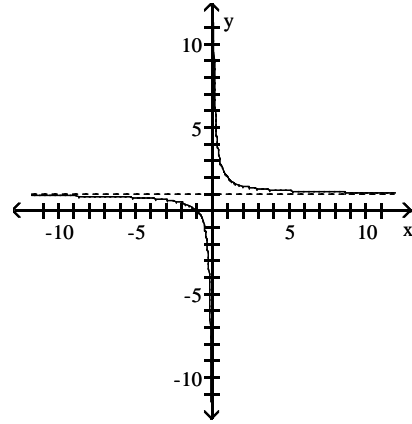

C)

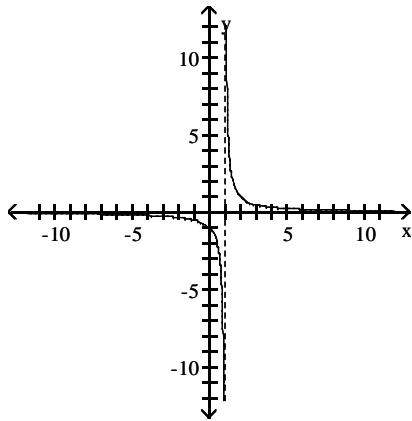

D)

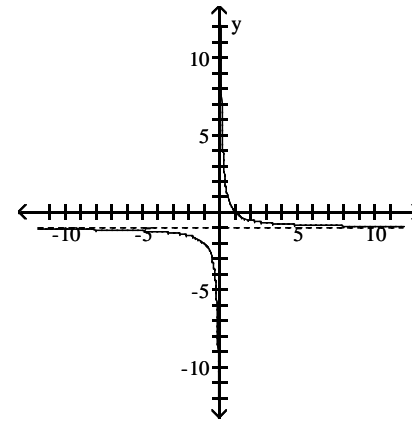

30) $f(x) = \frac{1}{x+4}$

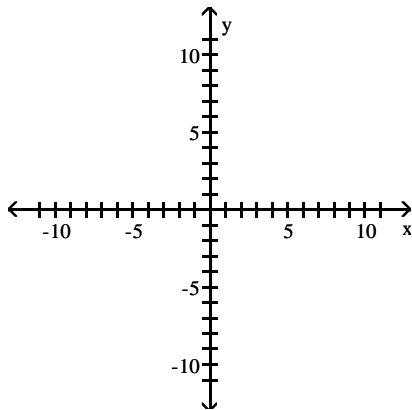

A)

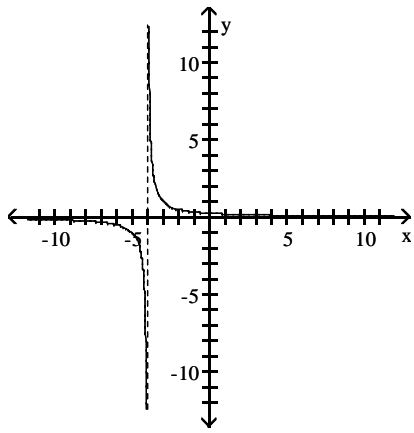

B)

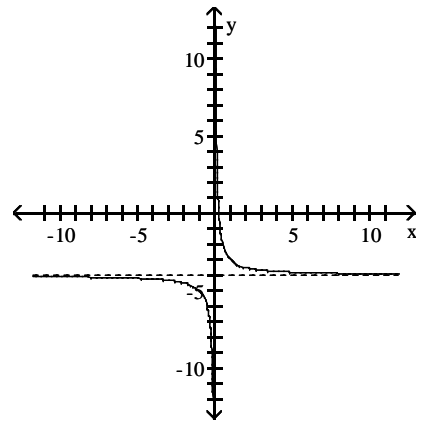

C)

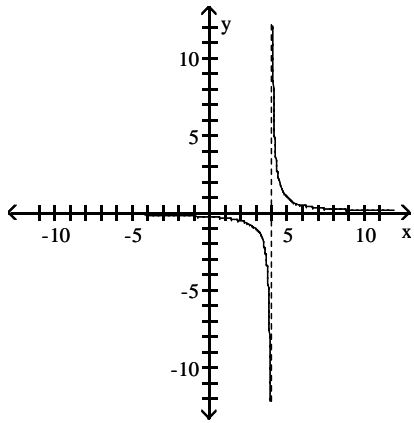

D)

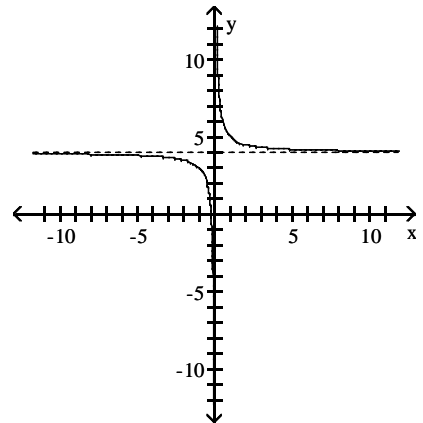

$$31) f(x) = \frac{1}{x+4} + 7$$

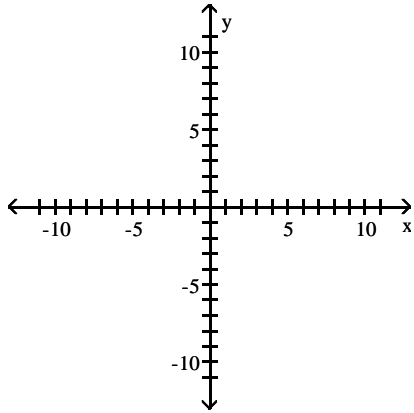

A)

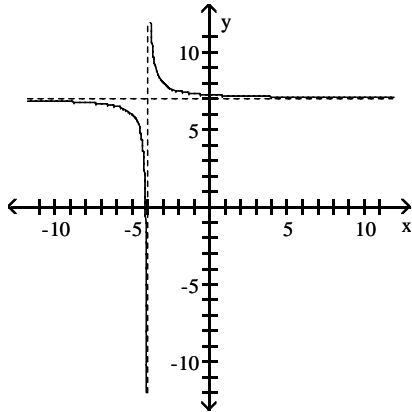

B)

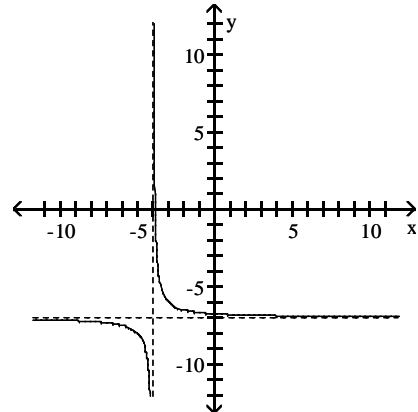

C)

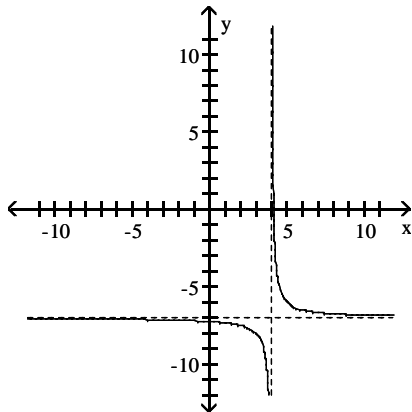

D)

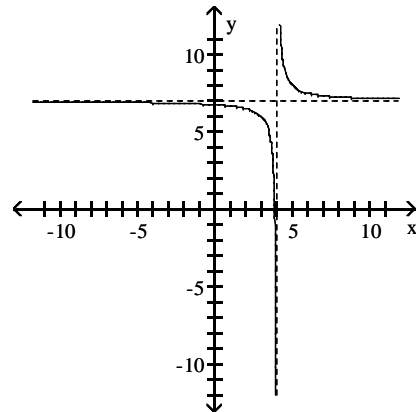

Using transformations, sketch the graph of the requested function.

32) The graph of a function f is illustrated. Use the graph of f as the first step toward graphing the function $F(x)$, where $F(x) = f(x + 2) - 1$.

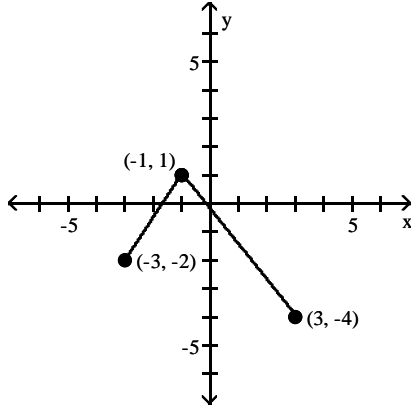

A)

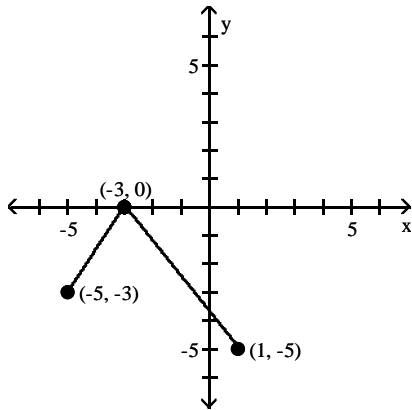

C)

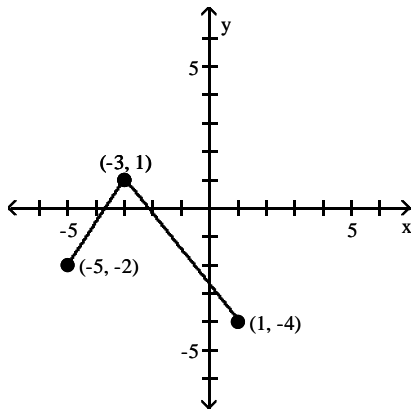

B)

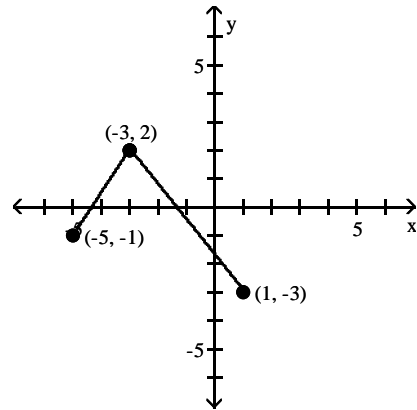

D)

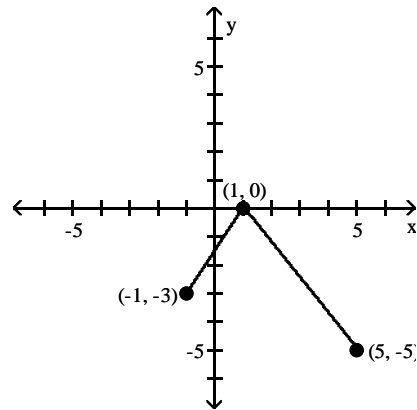

Complete the square and then use the shifting technique to graph the function.

33) $f(x) = x^2 - 4x$

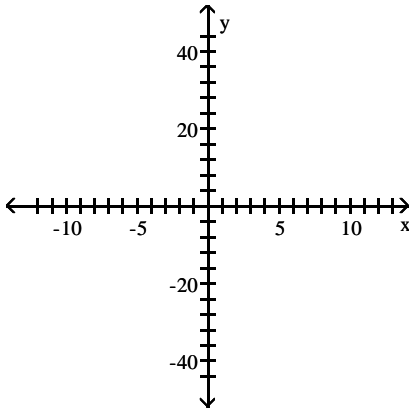

A)

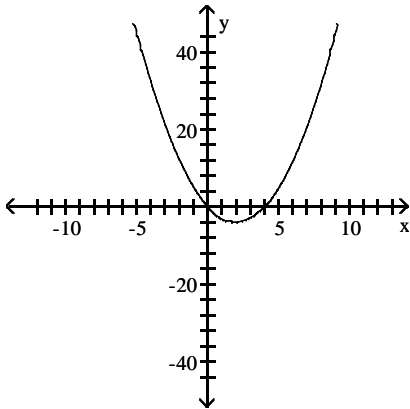

B)

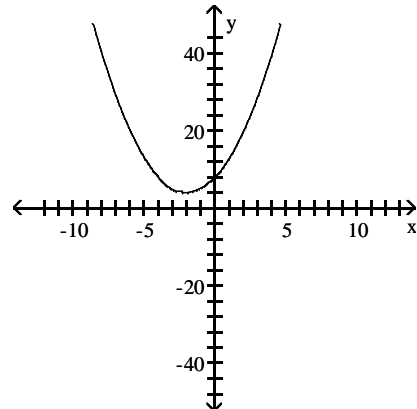

C)

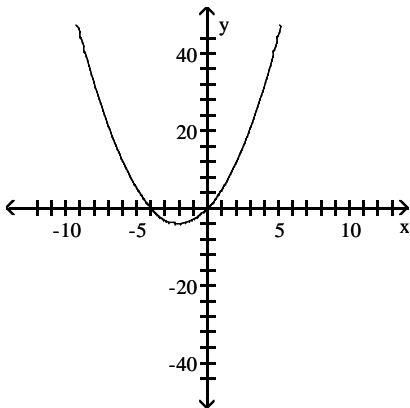

D)

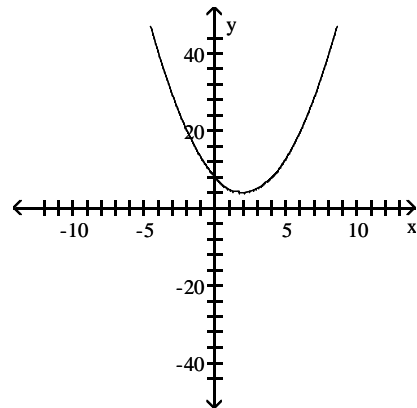

34) $f(x) = x^2 + 2x - 3$

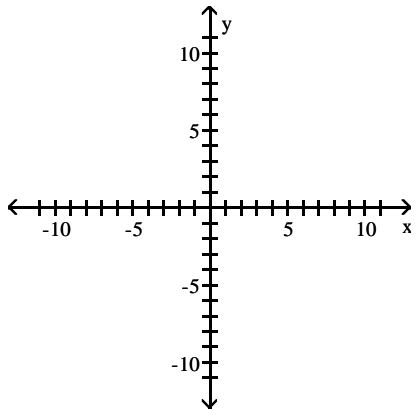

A)

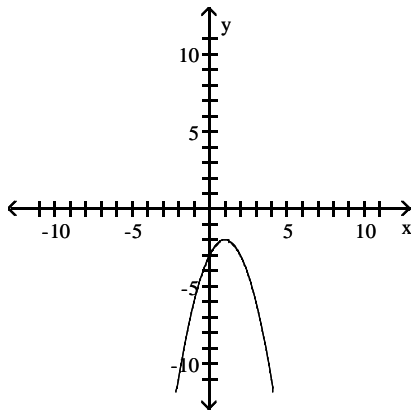

B)

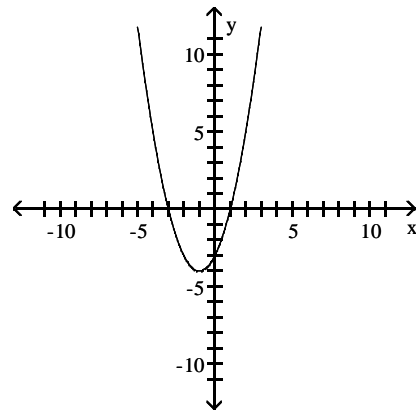

C)

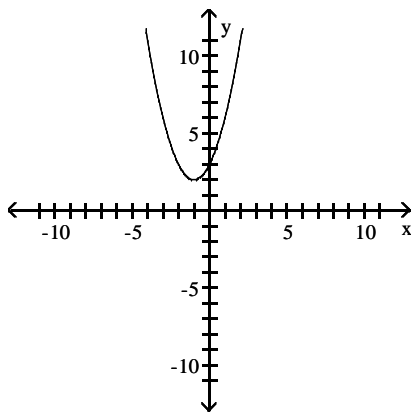

D)

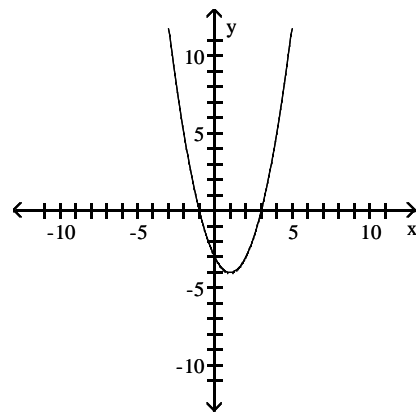

Solve the problem.

35) The following numerical representation for f computes the average number of hours of television watched per day based on year of birth x .

x	1975	1980	1983	1988	1990	1992	1995
$f(x)$	2	2.5	3	3.5	4	3.5	4

Give a numerical representation for a function g that computes the average number of hours of television watched per day for the year x , where $x = 0$ corresponds to the birth year 1975. Write an equation that shows the relationship between $f(x)$ and $g(x)$.

A) $\frac{x}{g(x)} \left| \begin{array}{cccccc} 75 & 80 & 83 & 88 & 90 & 92 & 95 \\ 2 & 2.5 & 3 & 3.5 & 4 & 3.5 & 4 \end{array} \right.$; $f(x) = g(x - 1900)$

B) $\frac{x}{g(x)} \left| \begin{array}{cccccc} 0 & 5 & 8 & 13 & 15 & 17 & 20 \\ 2 & 2.5 & 3 & 3.5 & 4 & 3.5 & 4 \end{array} \right.$; $f(x) = g(x - 1975)$

C) $\frac{x}{g(x)} \left| \begin{array}{cccccc} 0 & 5 & 8 & 13 & 15 & 17 & 20 \\ 2 & 2.5 & 3 & 3.5 & 4 & 3.5 & 4 \end{array} \right.$; $f(x) = g(x + 1975)$

D) $\frac{x}{g(x)} \left| \begin{array}{cccccc} 0 & 5 & 8 & 13 & 15 & 17 & 20 \\ 2 & 2.5 & 3 & 3.5 & 4 & 3.5 & 4 \end{array} \right.$; $f(x) = g(x) - 1975$

36) Suppose a cold front is passing through the United States at noon with a shape described by the function $y = \frac{1}{23}x^2$, where each unit represents 100 miles. St. Louis, Missouri is located at $(0, 0)$, and the positive y -axis points north.

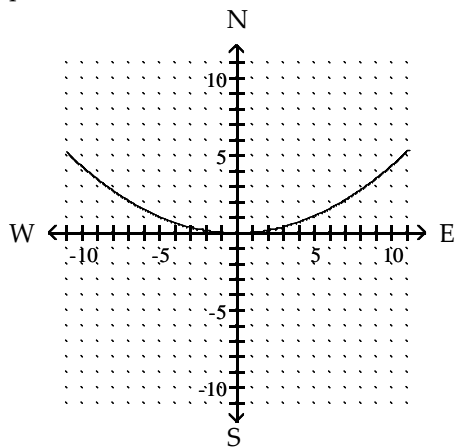

Suppose the front moves south 340 miles and west 120 miles and maintains its shape. Give the equation for the new front and plot the new position of the front.

$$A) y = \frac{1}{23}(x - 1.2)^2 - 3.4$$

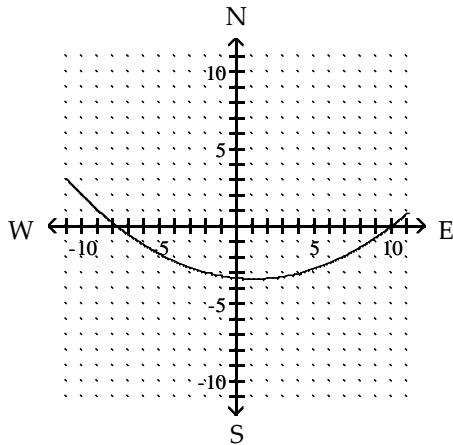

$$B) y = \frac{1}{23}(x - 1.2)^2 + 3.4$$

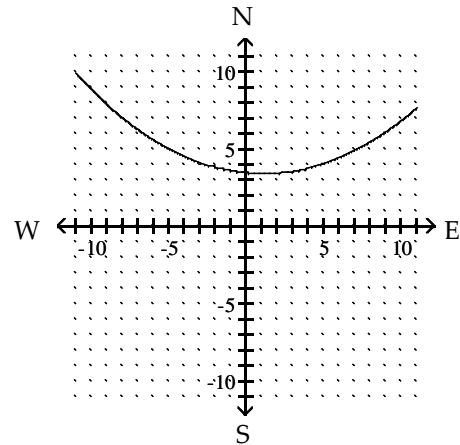

$$C) y = -\frac{1}{23}(x + 1.2)^2 - 3.4$$

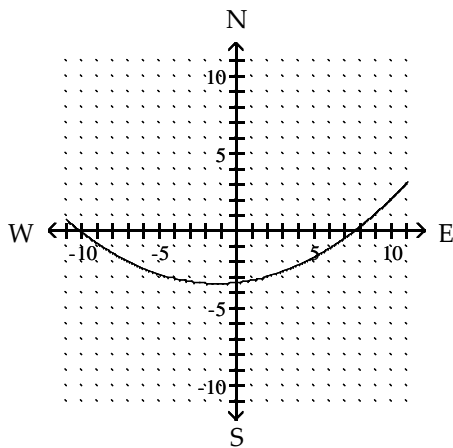

$$D) y = \frac{1}{23}(x + 1.2)^2 - 3.4$$

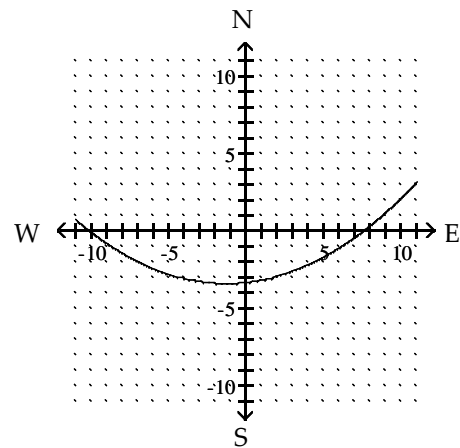

2 Graph Functions Using Compressions and Stretches

MULTIPLE CHOICE. Choose the one alternative that best completes the statement or answers the question.

Write the equation that results in the desired transformation.

1) The graph of $y = x^2$, vertically stretched by a factor of 3

A) $y = (x - 3)^2$

B) $y = -3x^2$

C) $y = 3(x - 3)x^2$

D) $y = 3x^2$

2) The graph of $y = x^3$, vertically compressed by a factor of 0.9

A) $y = (x - 0.9)^3$

B) $y = 0.9\sqrt[3]{x}$

C) $y = 0.9x^3$

D) $y = (x + 0.9)^3$

Suppose the point (2, 4) is on the graph of $y = f(x)$. Find a point on the graph of the given function.

3) $y = 2f(x)$

A) (2, 8)

B) (1, 4)

C) (4, 4)

D) (5, 1)

Solve the problem.

4) Suppose that the x-intercepts of the graph of $y = f(x)$ are 2 and 4. What are the x-intercepts of $y = 3f(x)$?

A) 5 and 7

B) 8 and 12

C) 2 and 4

D) -1 and 1

Graph the function by starting with the graph of the basic function and then using the techniques of shifting, compressing, stretching, and/or reflecting.

5) $f(x) = 2x^2$

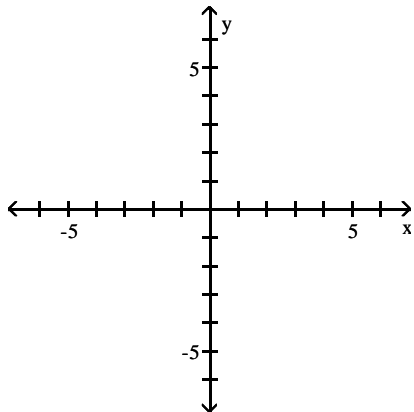

A)

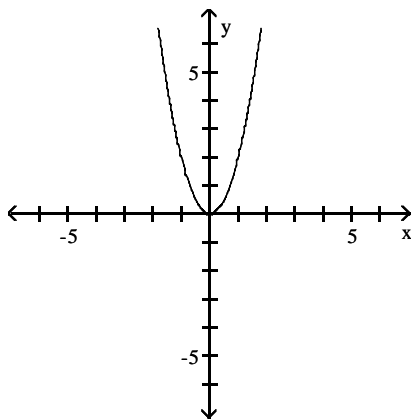

B)

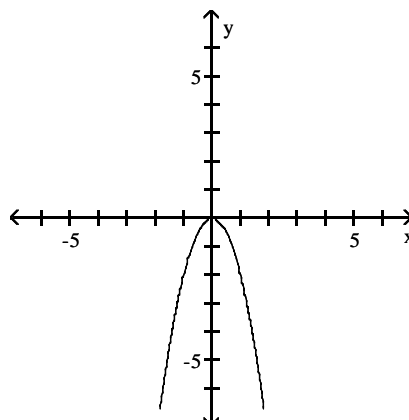

C)

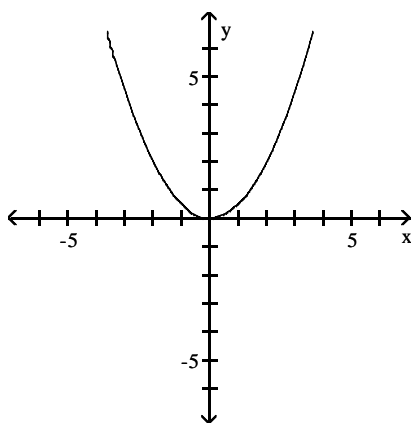

D)

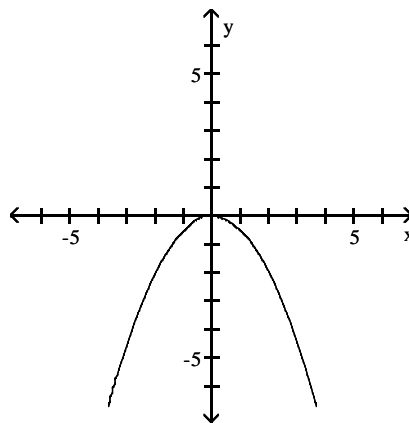

6) $f(x) = \frac{1}{3}x^2$

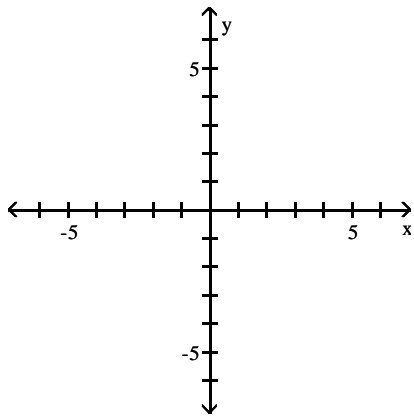

A)

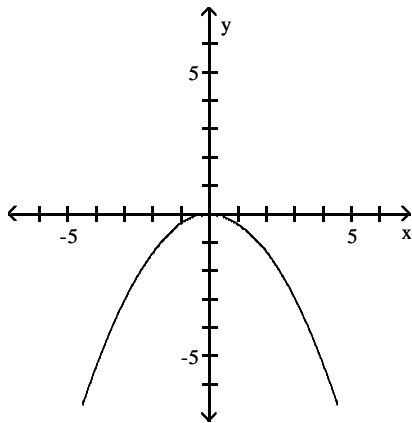

B)

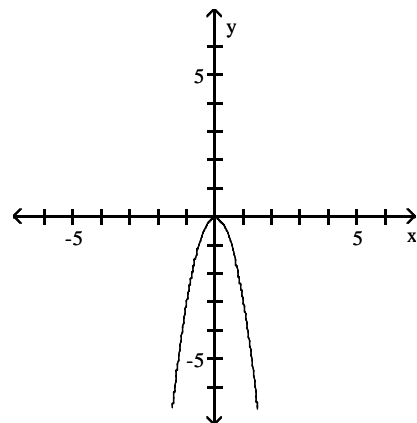

C)

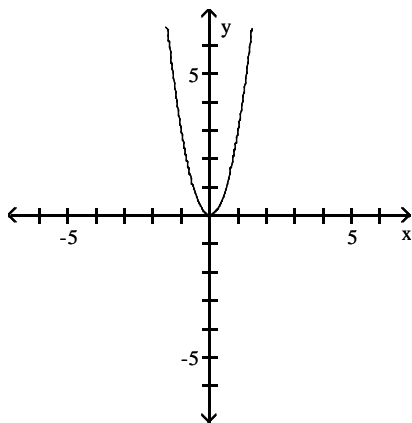

D)

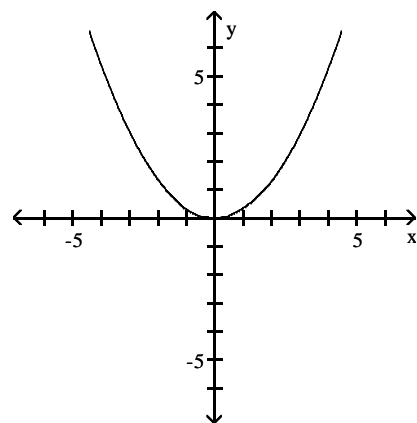

7) $f(x) = 3x^3$

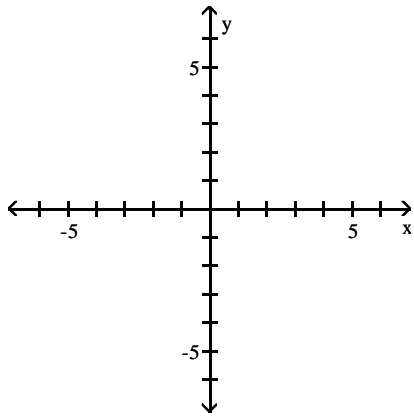

A)

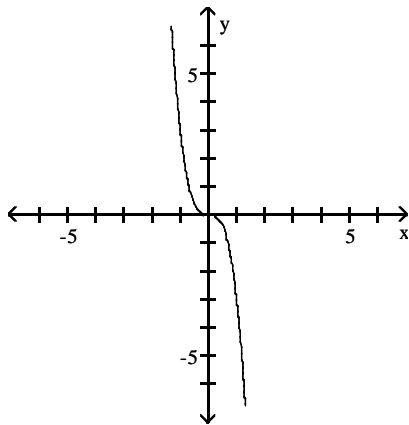

B)

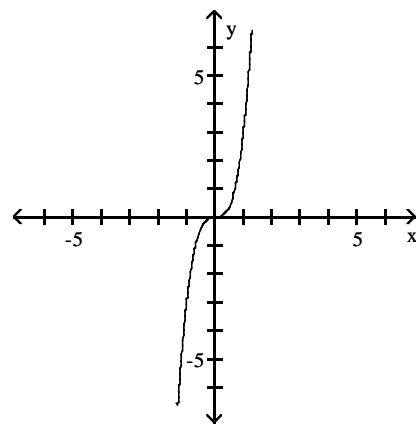

C)

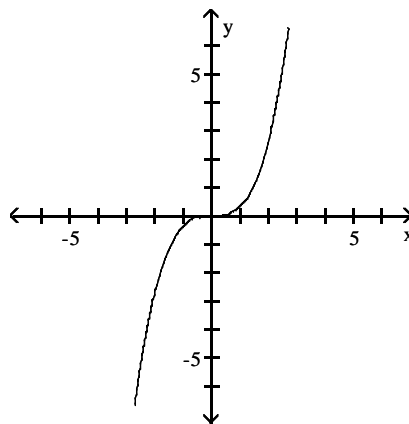

D)

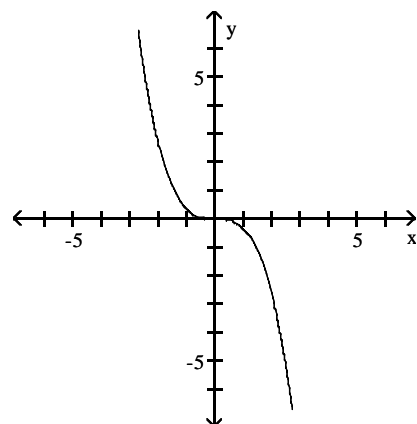

8) $f(x) = \frac{1}{4}x^3$

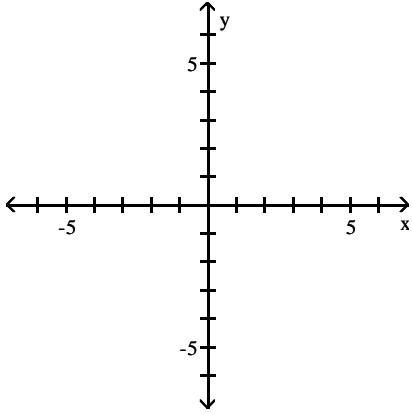

A)

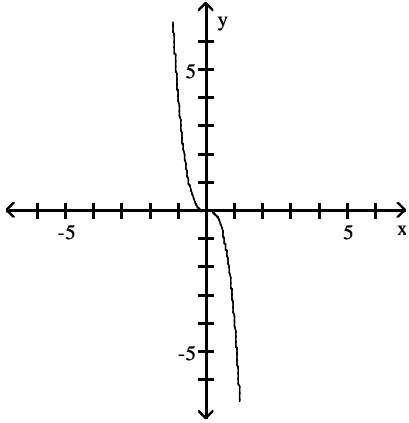

B)

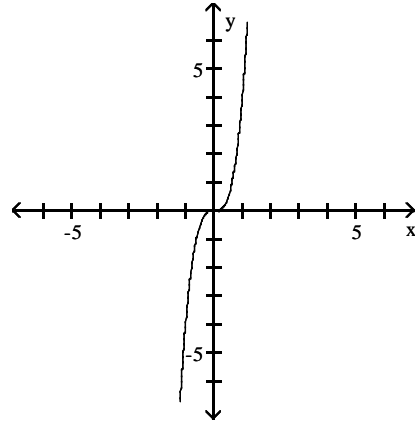

C)

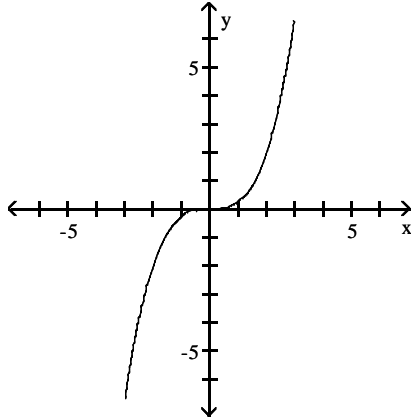

D)

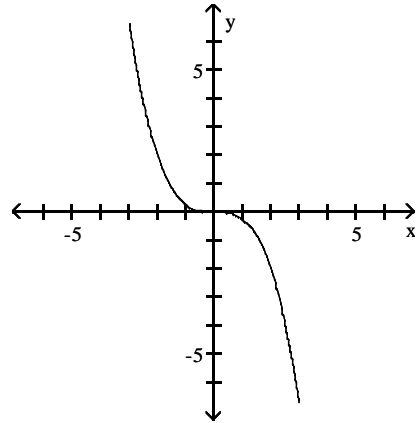

9) $f(x) = 6\sqrt{x}$

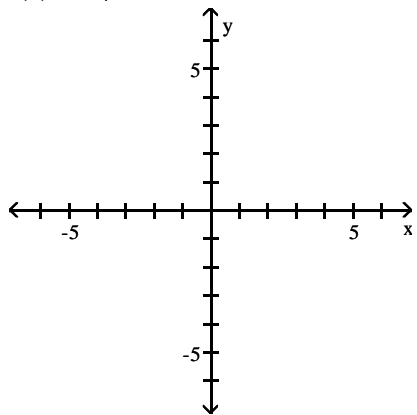

A)

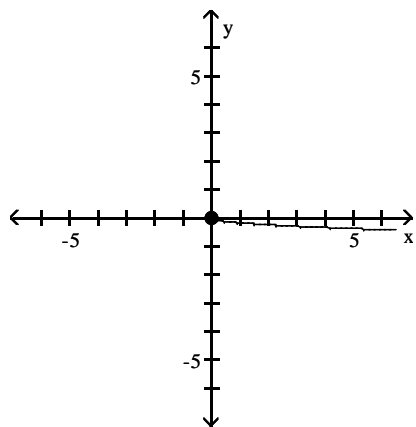

C)

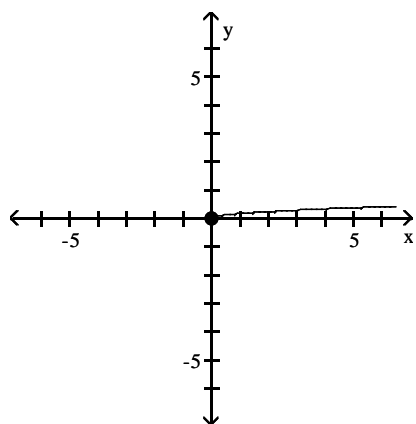

B)

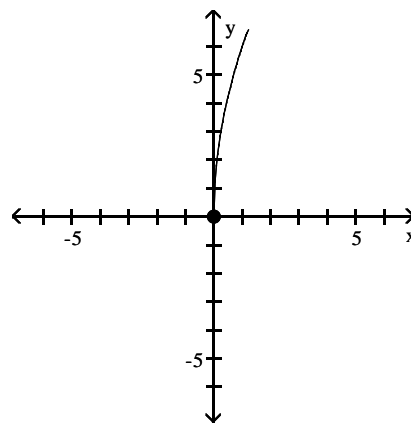

D)

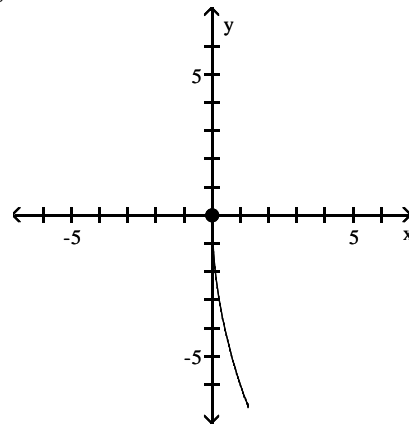

10) $f(x) = \frac{1}{6}\sqrt{x}$

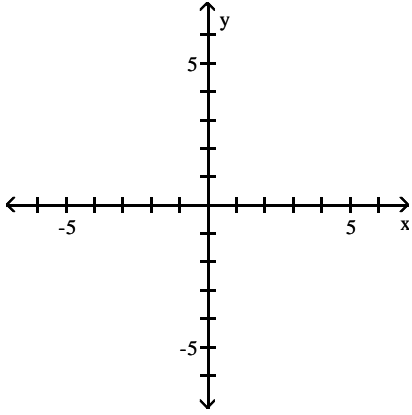

A)

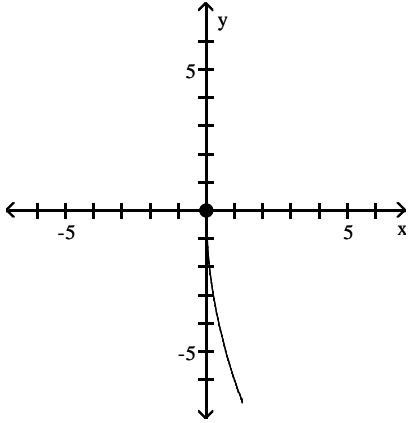

C)

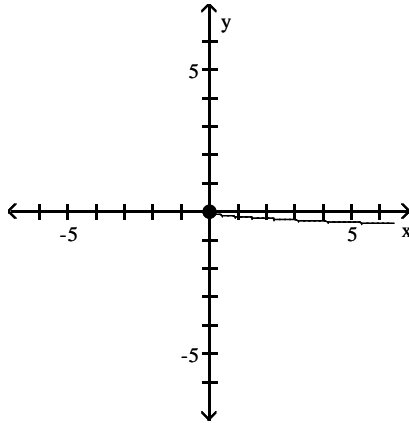

B)

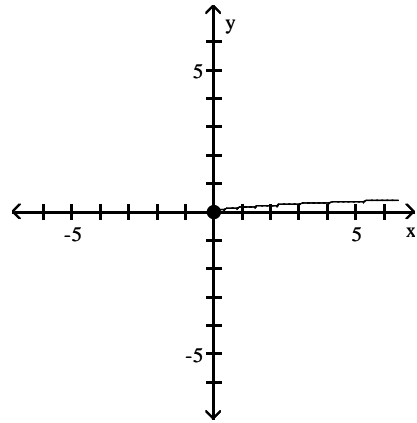

D)

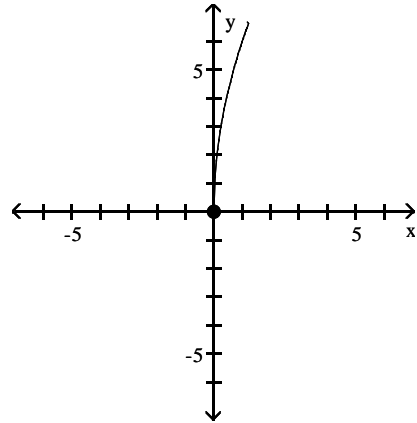

11) $f(x) = 5|x|$

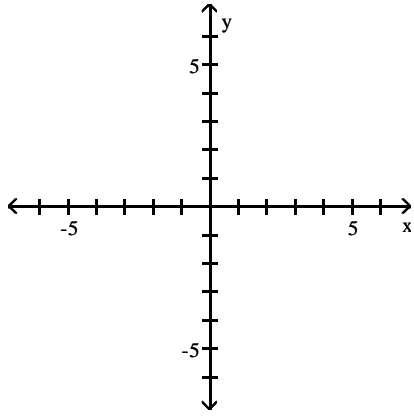

A)

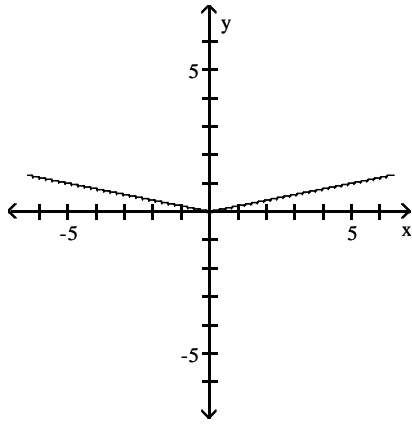

B)

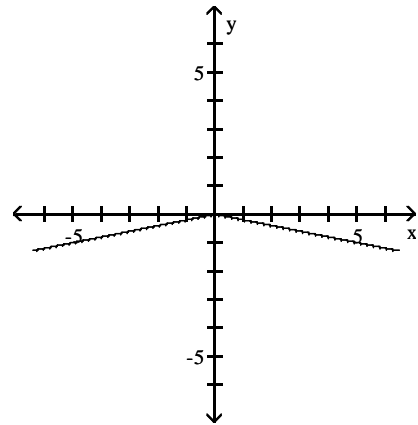

C)

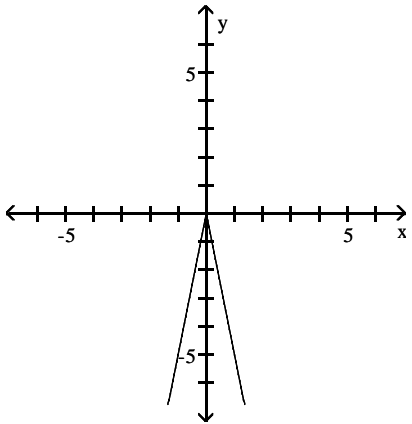

D)

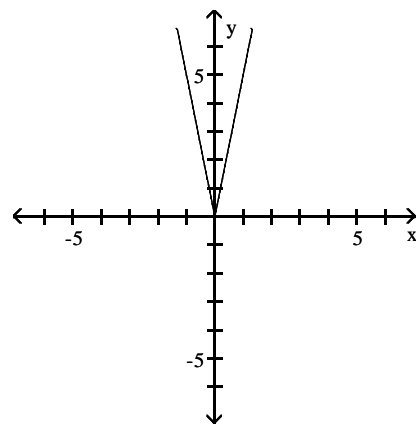

12) $f(x) = \frac{1}{5}|x|$

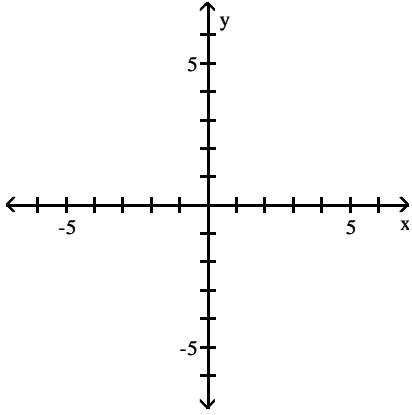

A)

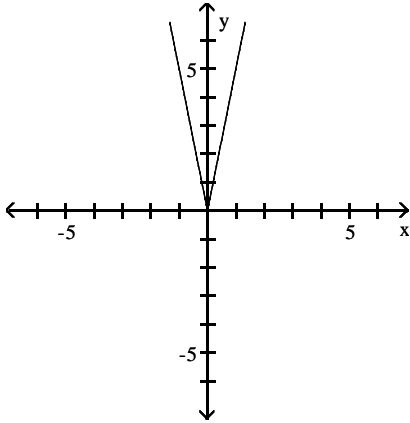

B)

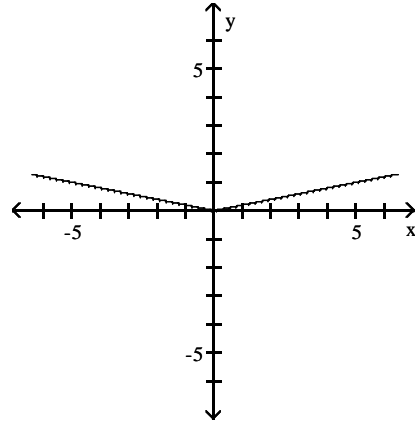

C)

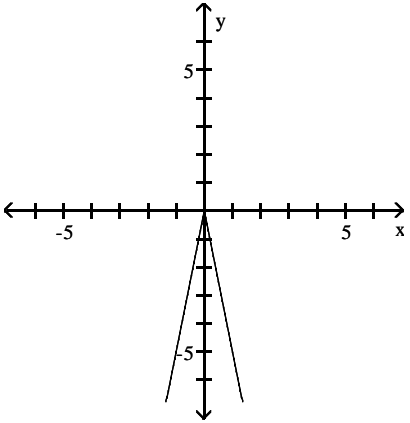

D)

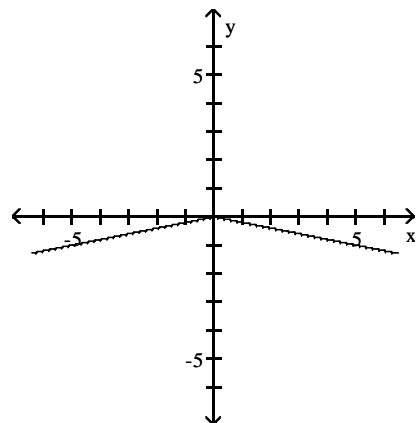

13) $f(x) = \frac{3}{x}$

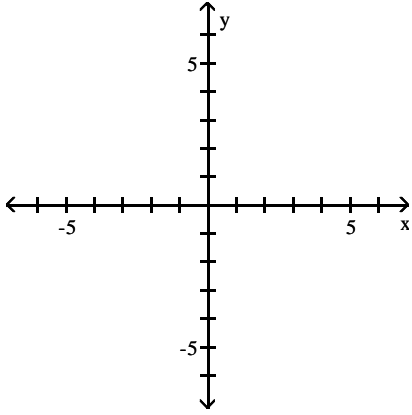

A)

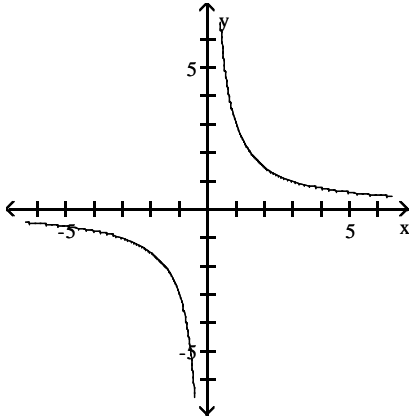

C)

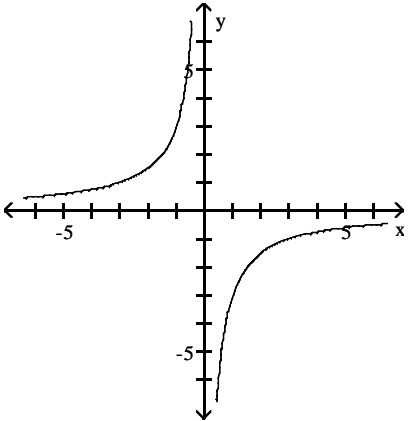

B)

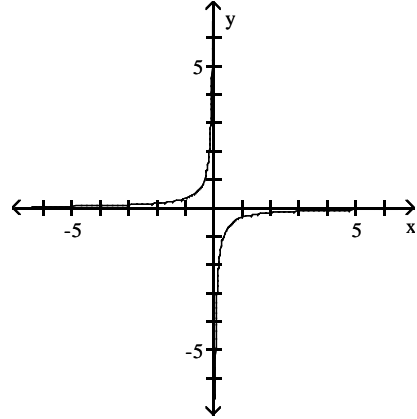

D)

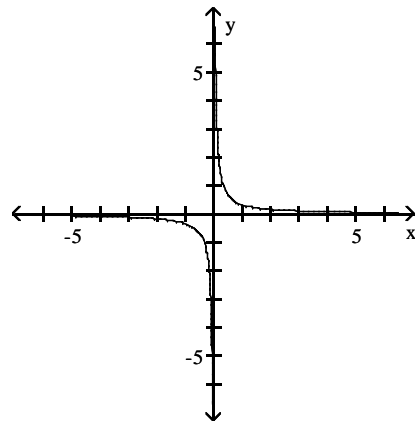

14) $f(x) = \frac{1}{3x}$

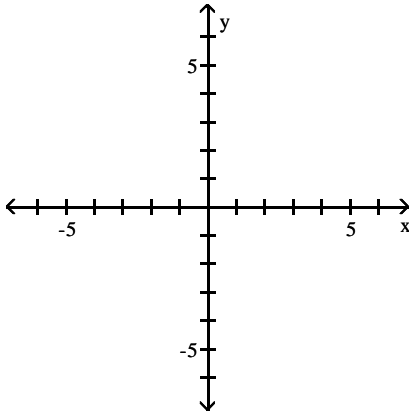

A)

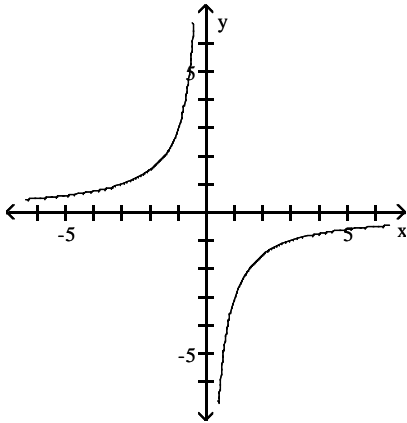

B)

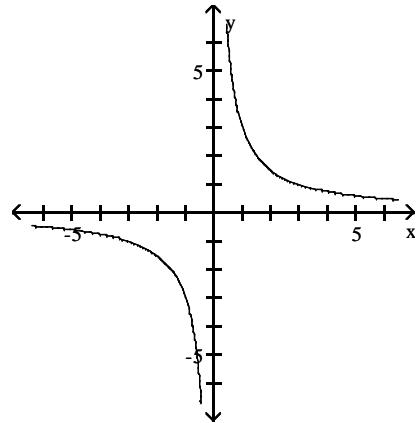

C)

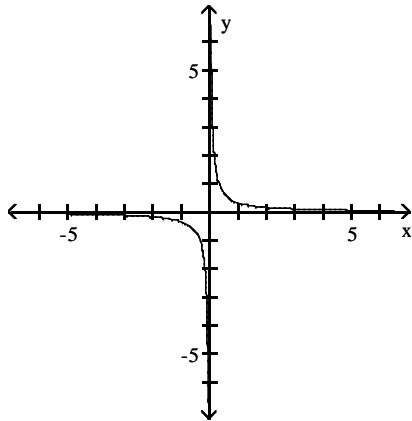

D)

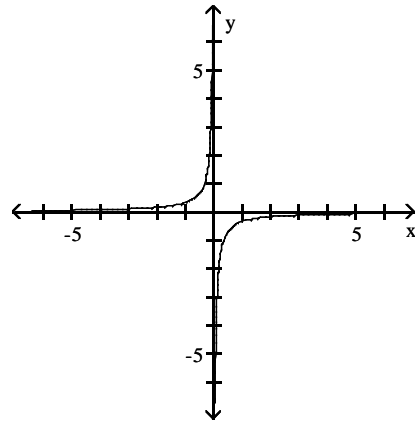

15) $f(x) = 3(x + 1)^2 + 2$

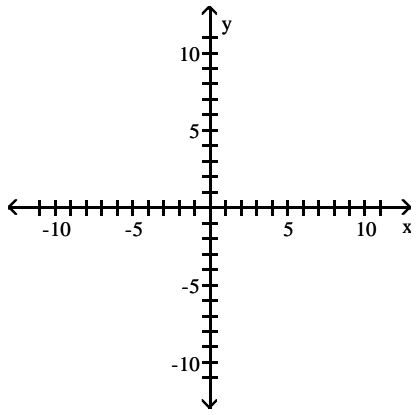

A)

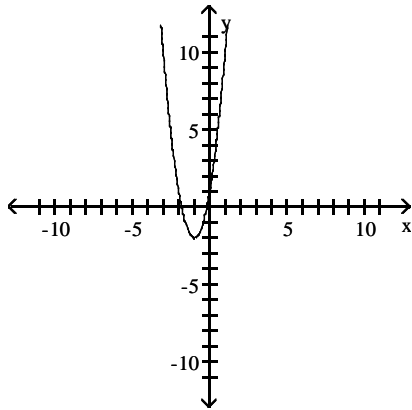

B)

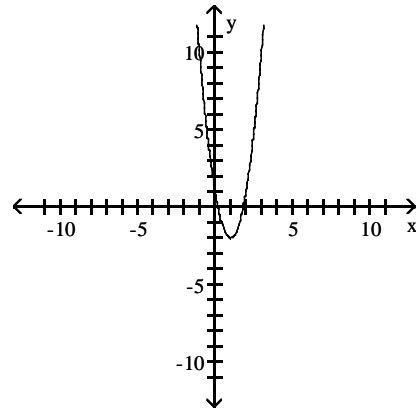

C)

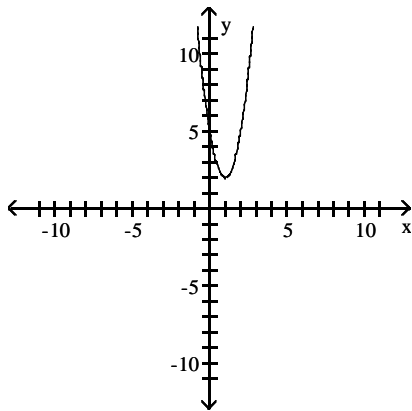

D)

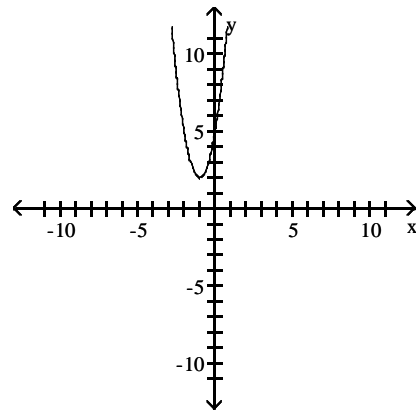

Use the accompanying graph of $y = f(x)$ to sketch the graph of the indicated equation.

16) $y = 2f(x)$

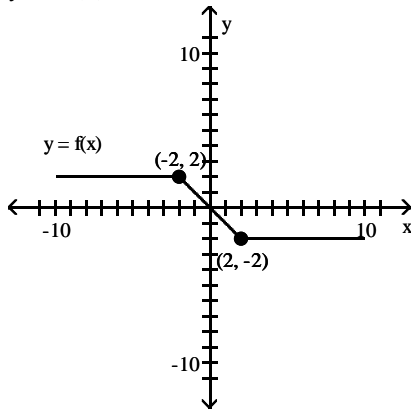

A)

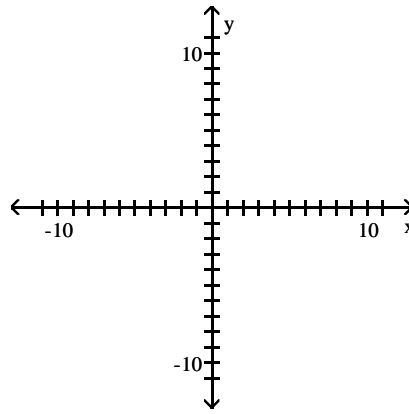

B)

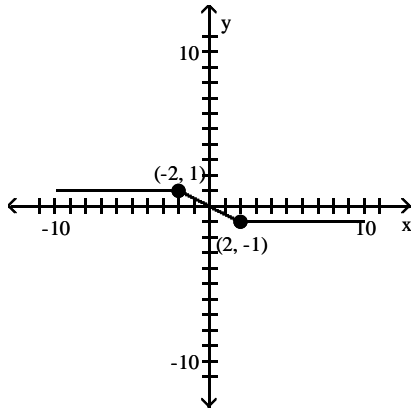

C)

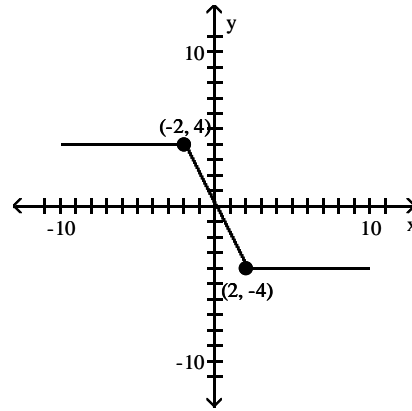

D)

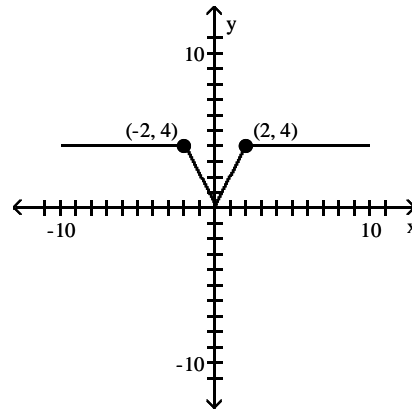
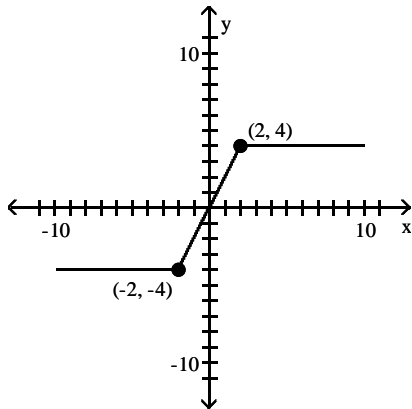

$$17) y = -\frac{1}{2}f(x)$$

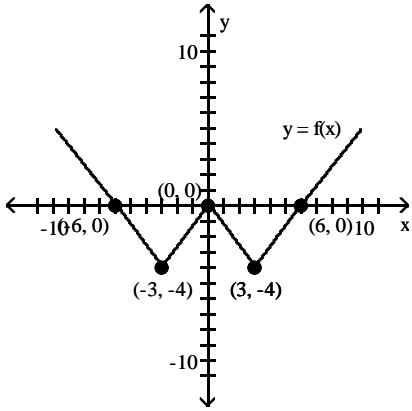

A)

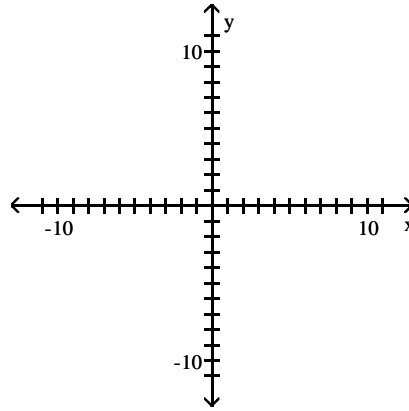

B)

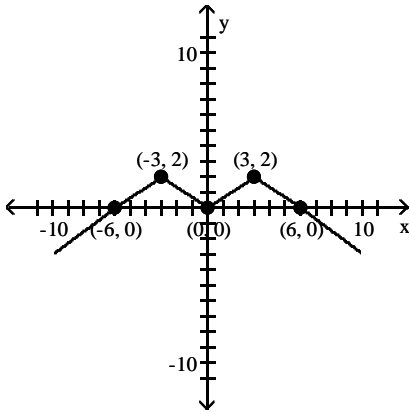

C)

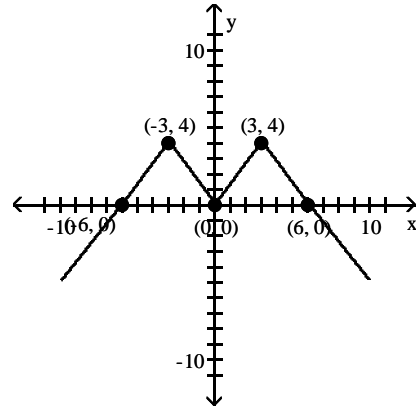

D)

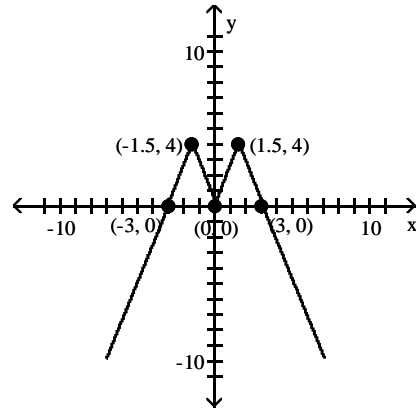
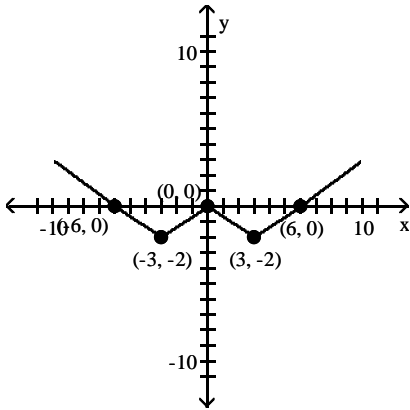

$$18) y = -\frac{1}{3}f(x + 5) + 2$$

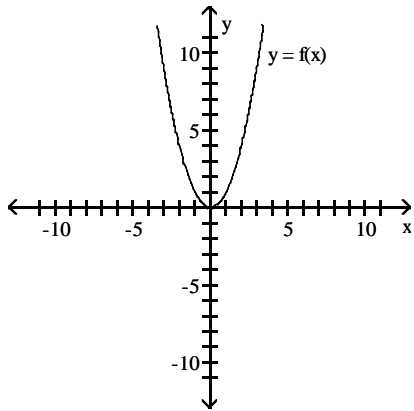

A)

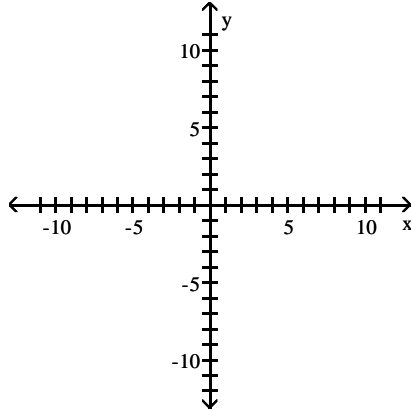

B)

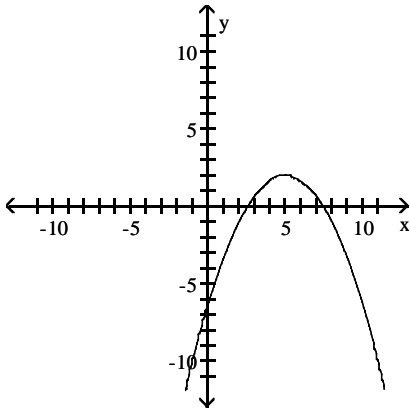

C)

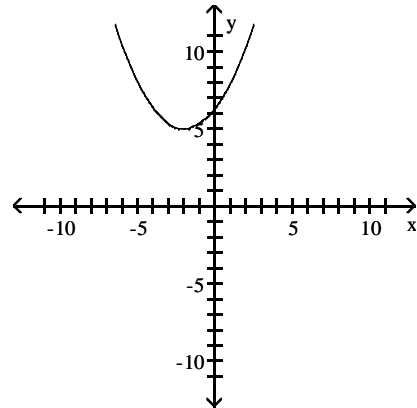

D)

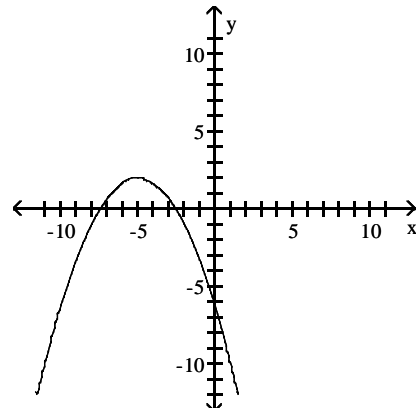
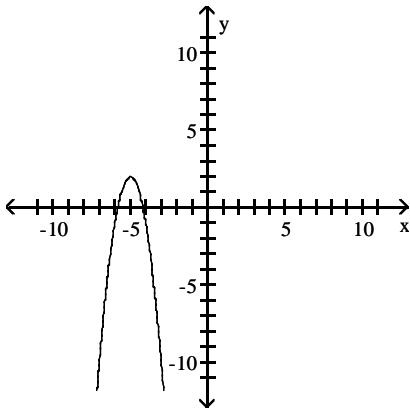

3 Graph Functions Using Reflections about the x-Axis or y-Axis

MULTIPLE CHOICE. Choose the one alternative that best completes the statement or answers the question.

Match the correct function to the graph.

1)

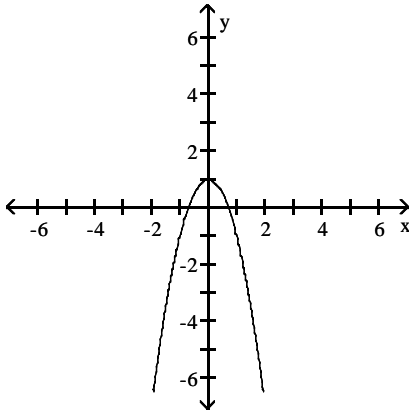

A) $y = 1 - x^2$

B) $y = -2x^2 + 1$

C) $y = -2x^2$

D) $y = -2x^2 - 1$

Suppose the point (2, 4) is on the graph of $y = f(x)$. Find a point on the graph of the given function.

2) The reflection of the graph of $y = f(x)$ across the x-axis

A) (2, -4)

B) (-2, 4)

C) (-2, -4)

D) (2, 4)

3) The reflection of the graph of $y = f(x)$ across the y-axis

A) (-2, -4)

B) (2, 4)

C) (2, -4)

D) (-2, 4)

Solve the problem.

4) Suppose that the x-intercepts of the graph of $y = f(x)$ are 2 and 4. What are the x-intercepts of $y = f(-x)$?

A) 2 and -4

B) 2 and 4

C) -2 and 4

D) -2 and -4

5) Suppose that the function $y = f(x)$ is decreasing on the interval (2, 5). What can be said about the graph of $y = -f(x)$?

A) decreasing on (-2, -5)

B) increasing on (2, 5)

C) decreasing on (2, 5)

D) increasing on (-2, -5)

Find the function.

6) Find the function that is finally graphed after the following transformations are applied to the graph of $y = |x|$. The graph is shifted right 3 units, stretched by a factor of 3, shifted vertically down 2 units, and finally reflected across the x-axis.

A) $y = -(3|x + 3| - 2)$

B) $y = -(3|x - 3| - 2)$

C) $y = -3|x - 3| - 2$

D) $y = 3|-x - 3| - 2$

7) Find the function that is finally graphed after the following transformations are applied to the graph of $y = \sqrt{x}$. The graph is shifted down 8 units, reflected about the y-axis, and finally shifted left 2 units.

A) $y = -\sqrt{x + 2} - 8$

B) $y = \sqrt{-x - 2} + 8$

C) $y = \sqrt{-x + 2} + 8$

D) $y = \sqrt{-x - 2} - 8$

8) Find the function that is finally graphed after the following transformations are applied to the graph of $y = |x|$. The graph is shifted up 6 units, reflected about the y-axis, and finally shifted right 2 units.

A) $y = |-x + 2| + 6$

B) $y = |-x - 2| - 6$

C) $y = -|x - 2| + 6$

D) $y = |-x + 2| - 6$

Graph the function by starting with the graph of the basic function and then using the techniques of shifting, compressing, stretching, and/or reflecting.

9) $f(x) = -x^2$

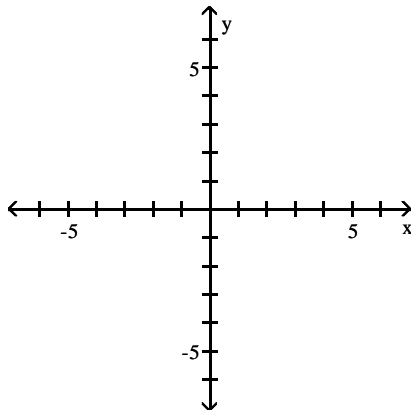

A)

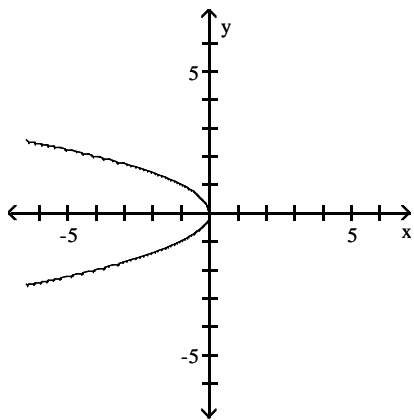

C)

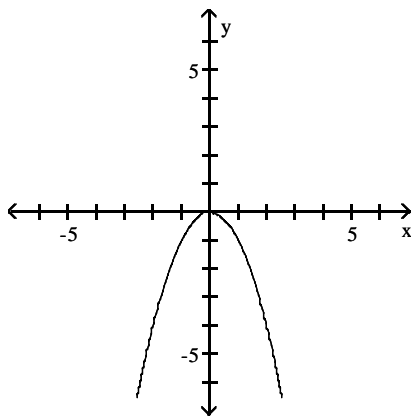

B)

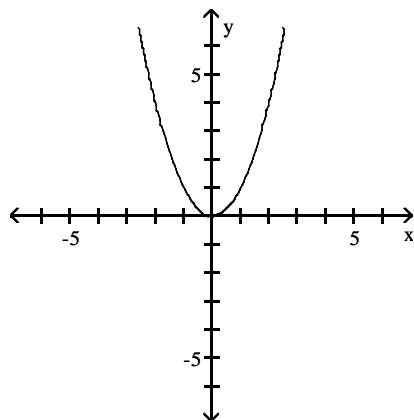

D)

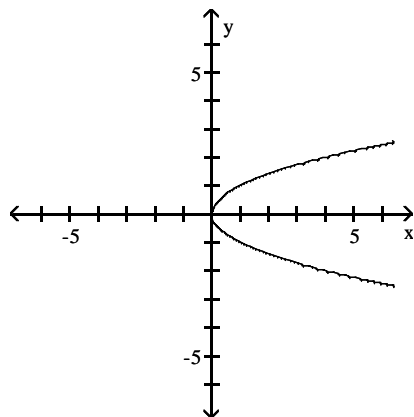

10) $f(x) = (-x)^2$

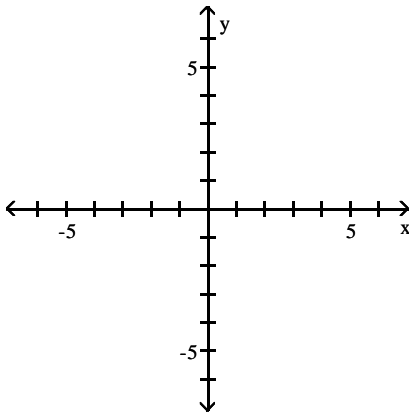

A)

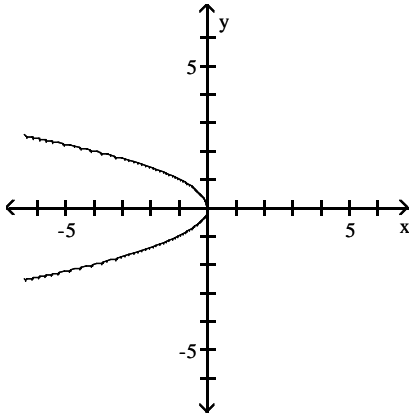

B)

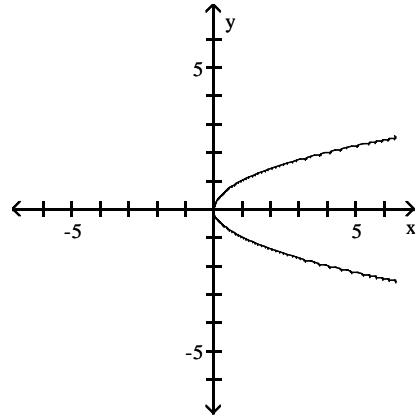

C)

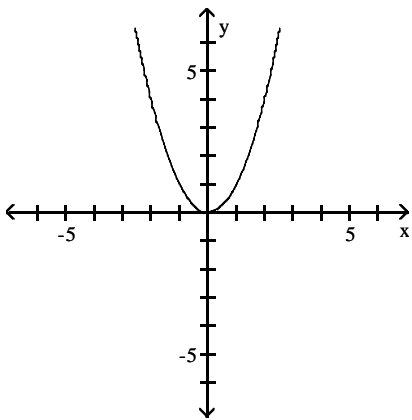

D)

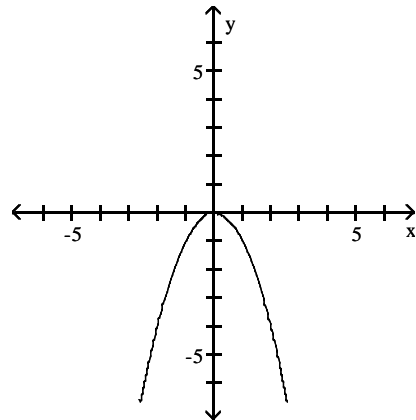

11) $f(x) = -x^3$

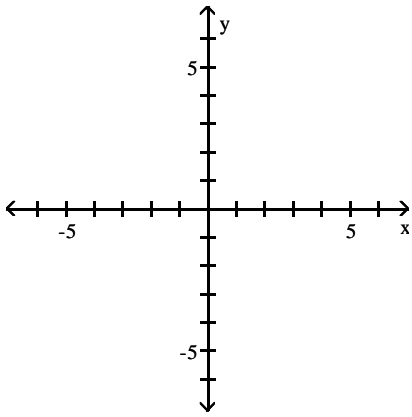

A)

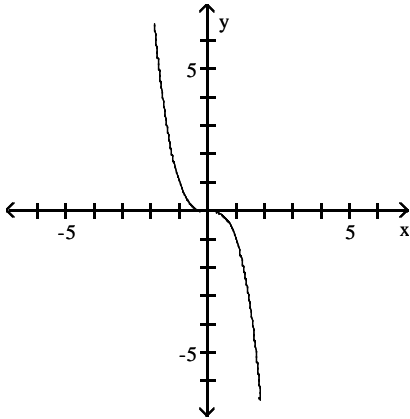

B)

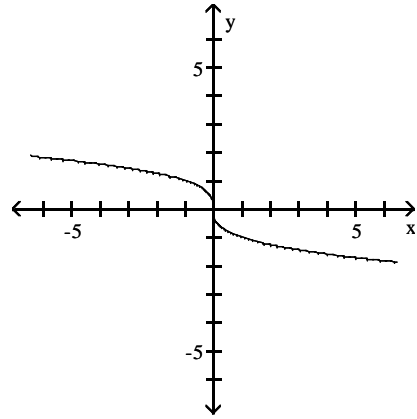

C)

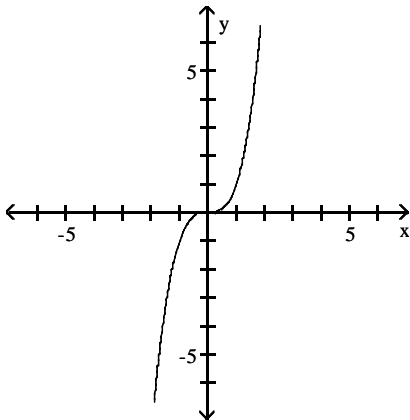

D)

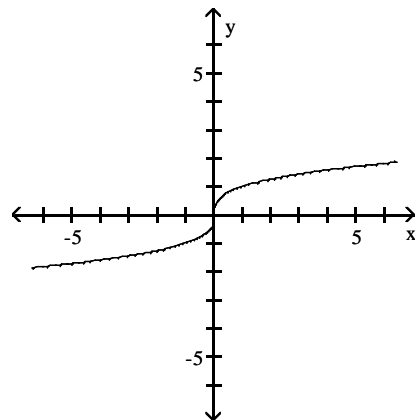

12) $f(x) = (-x)^3$

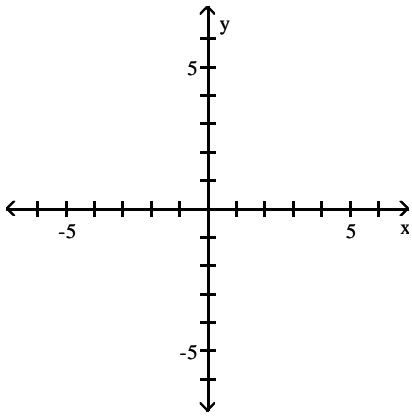

A)

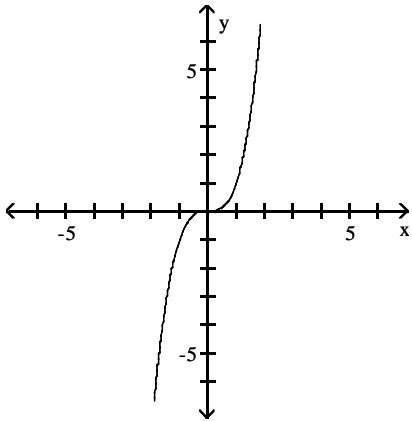

B)

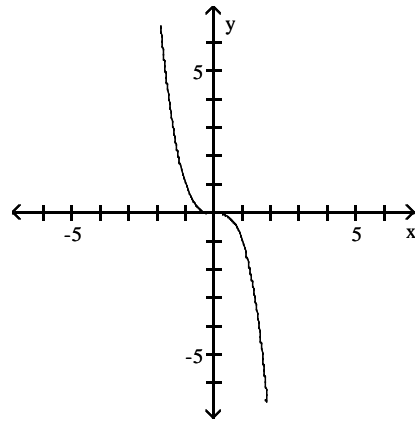

C)

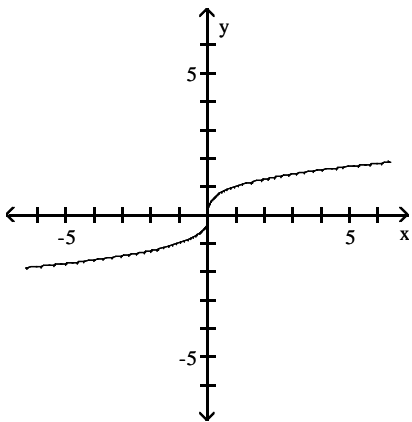

D)

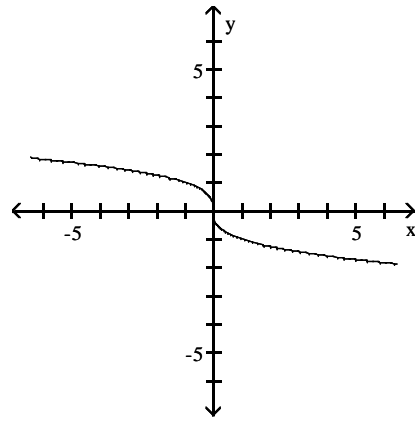

13) $f(x) = -\sqrt{x}$

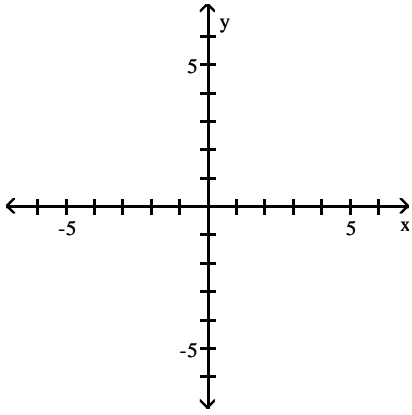

A)

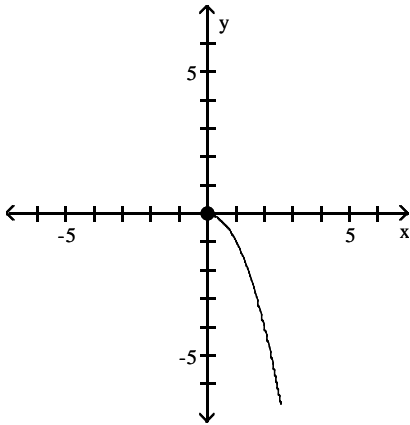

C)

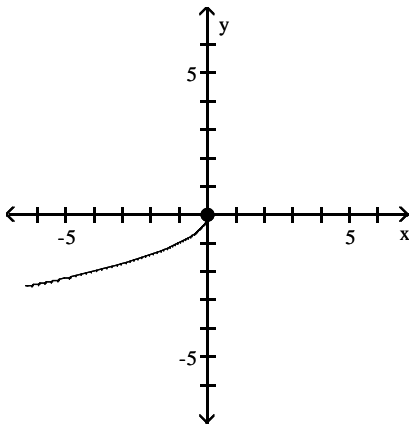

B)

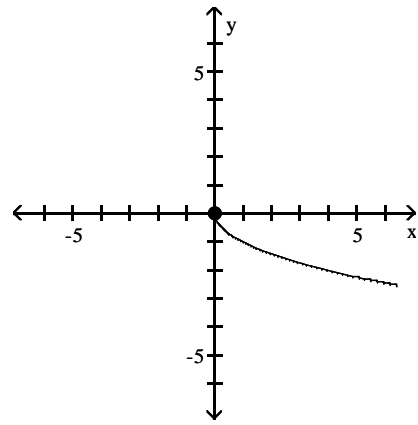

D)

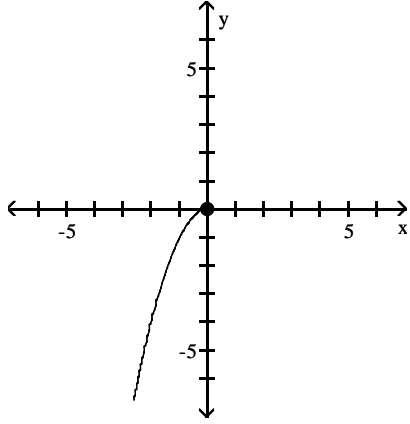

14) $f(x) = \sqrt{-x}$

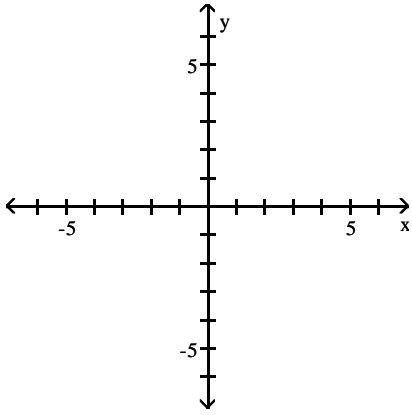

A)

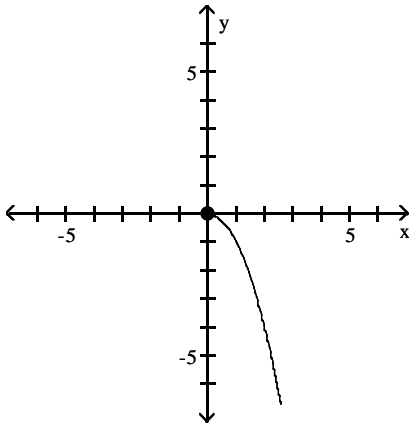

B)

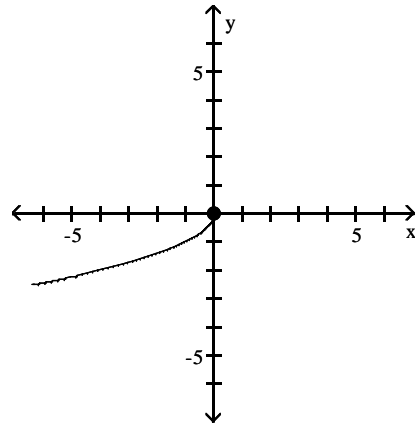

C)

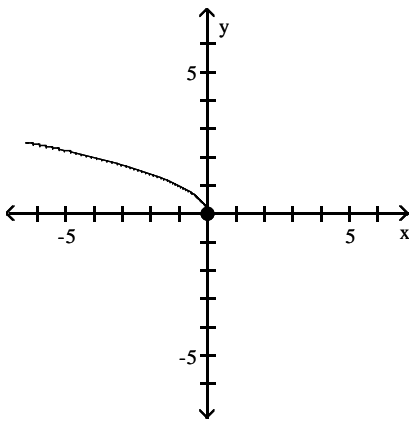

D)

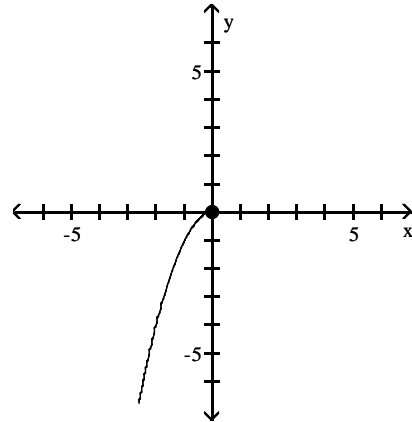

15) $f(x) = -|x|$

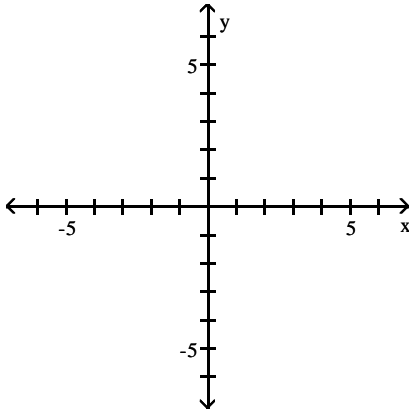

A)

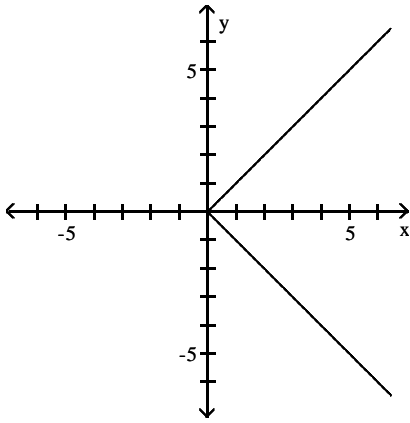

B)

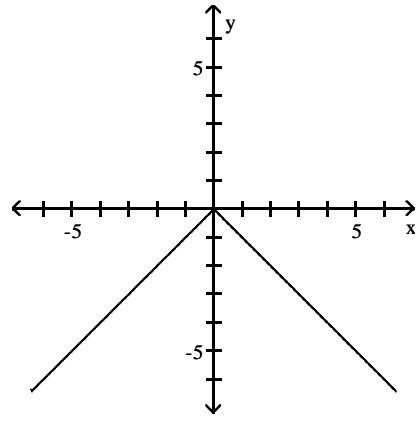

C)

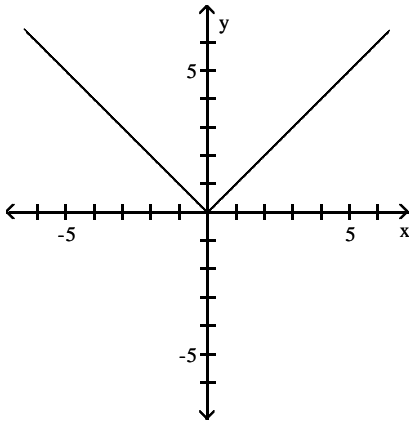

D)

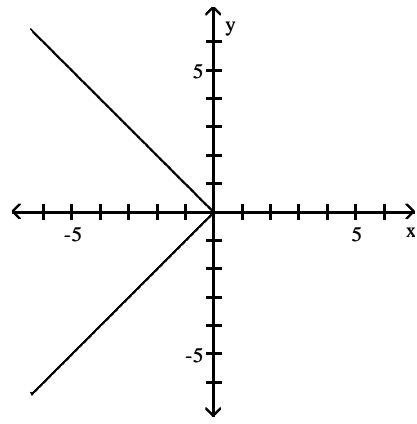

16) $f(x) = |-x|$

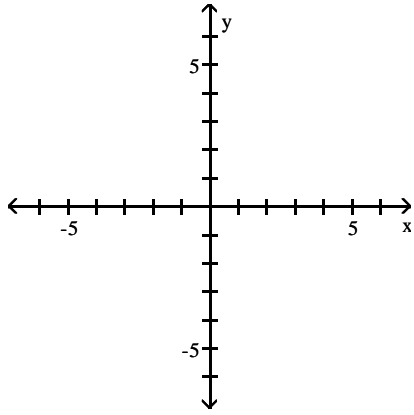

A)

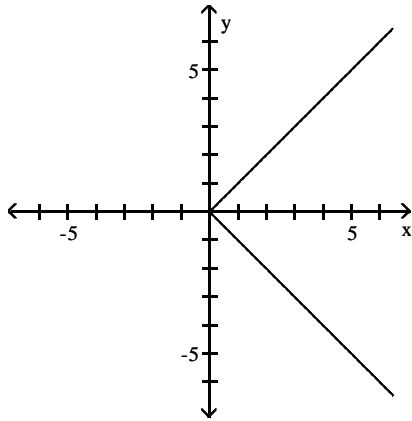

B)

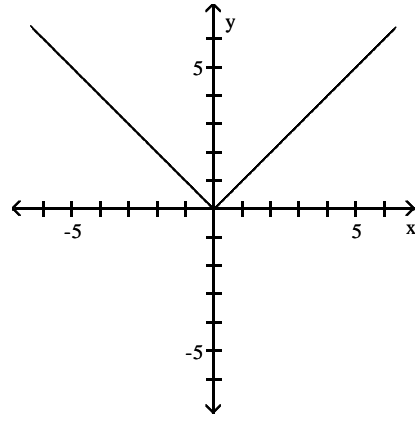

C)

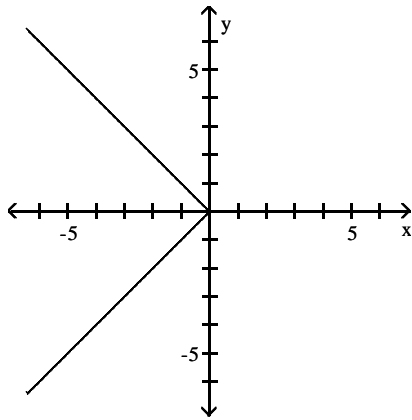

D)

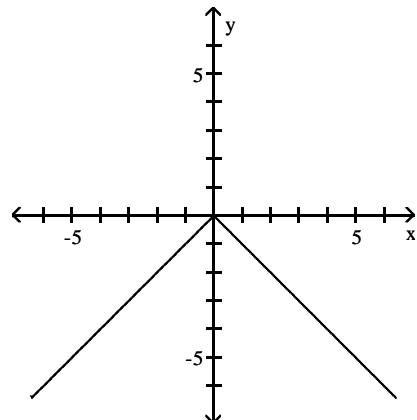

17) $f(x) = -\frac{1}{x}$

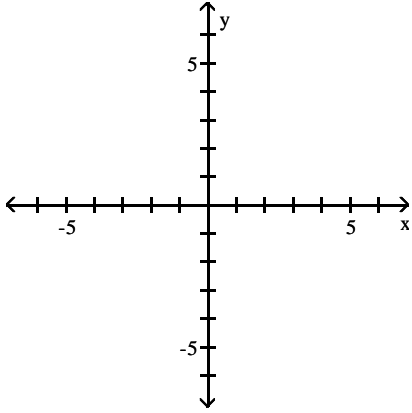

A)

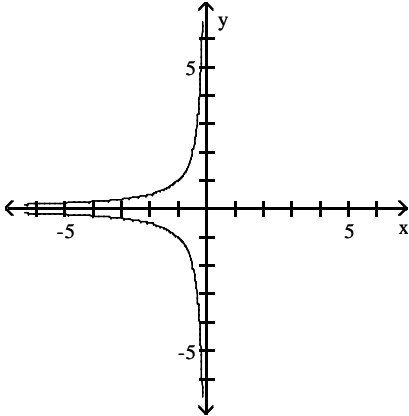

C)

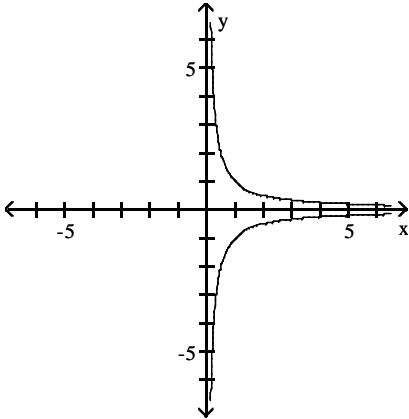

B)

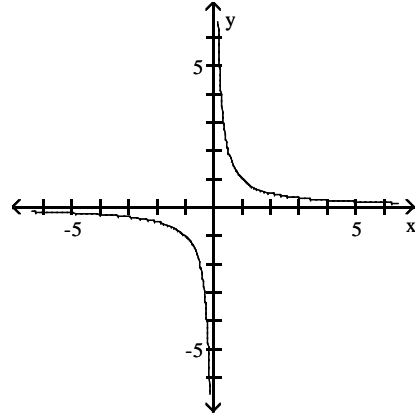

D)

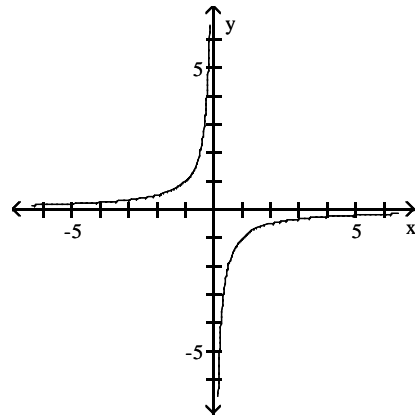

18) $f(x) = -(x - 6)^2 + 2$

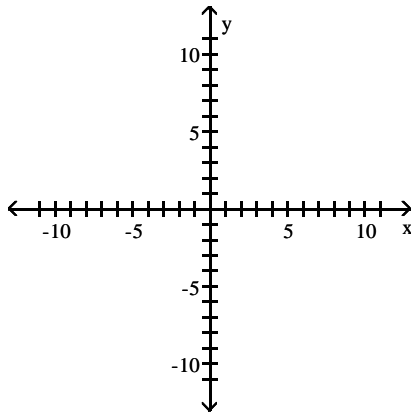

A)

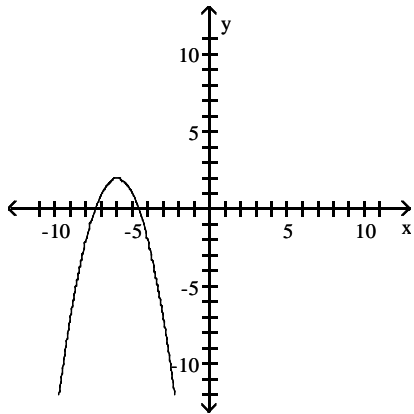

C)

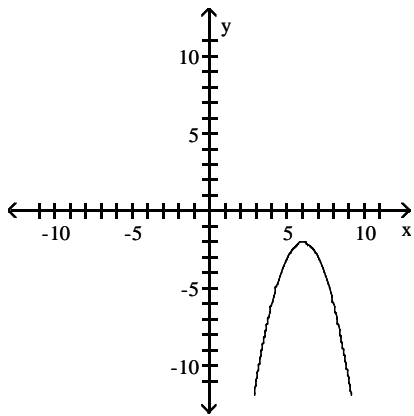

B)

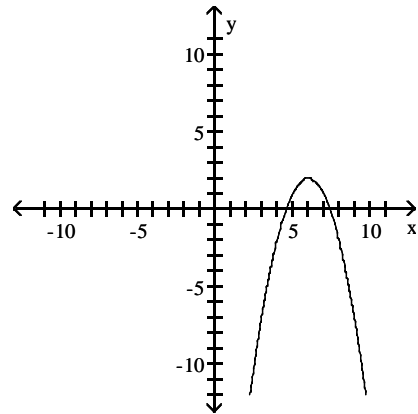

D)

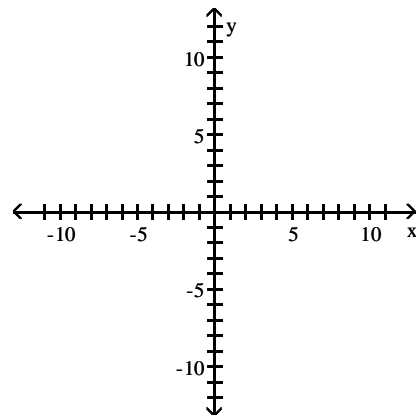

19) $f(x) = -2(x + 1)^2 - 4$

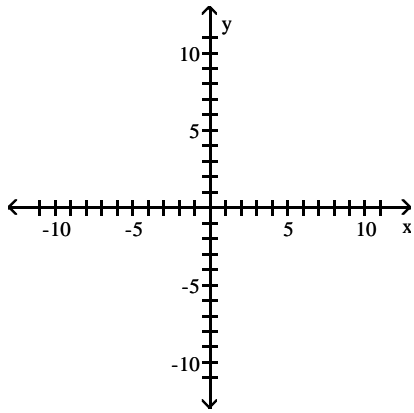

A)

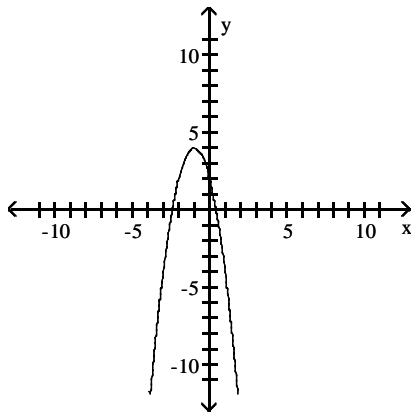

B)

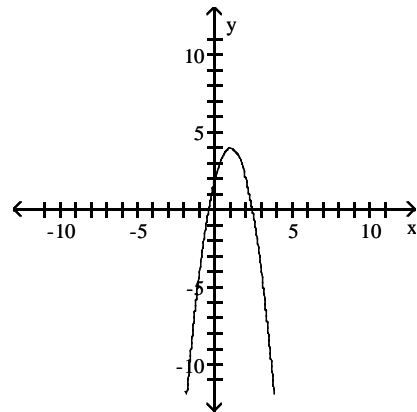

C)

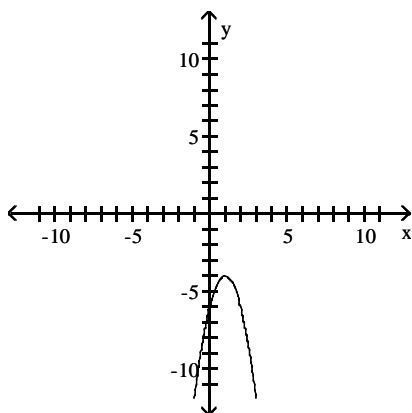

D)

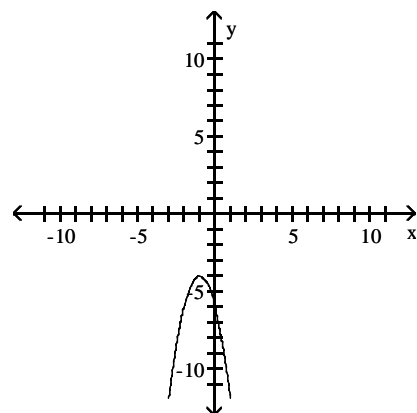

2.6 Mathematical Models: Building Functions

1 Build and Analyze Functions

MULTIPLE CHOICE. Choose the one alternative that best completes the statement or answers the question.

Solve the problem.

- 1) Elissa wants to set up a rectangular dog run in her backyard. She has 24 feet of fencing to work with and wants to use it all. If the dog run is to be x feet long, express the area of the dog run as a function of x .

A) $A(x) = 13x - x^2$ B) $A(x) = 12x - x^2$ C) $A(x) = 11x - x^2$ D) $A(x) = 14x^2 - x$

- 2) Bob wants to fence in a rectangular garden in his yard. He has 72 feet of fencing to work with and wants to use it all. If the garden is to be x feet wide, express the area of the garden as a function of x .

A) $A(x) = 38x^2 - x$ B) $A(x) = 35x - x^2$ C) $A(x) = 36x - x^2$ D) $A(x) = 37x - x^2$

3) Sue wants to put a rectangular garden on her property using 70 meters of fencing. There is a river that runs through her property so she decides to increase the size of the garden by using the river as one side of the rectangle. (Fencing is then needed only on the other three sides.) Let x represent the length of the side of the rectangle along the river. Express the garden's area as a function of x .

- A) $A(x) = 36x - 2x^2$ B) $A(x) = 34x - \frac{1}{4}x^2$ C) $A(x) = 35x - \frac{1}{2}x^2$ D) $A(x) = 35x^2 - x$

4) A farmer has 1200 yards of fencing to enclose a rectangular garden. Express the area A of the rectangle as a function of the width x of the rectangle. What is the domain of A ?

- A) $A(x) = x^2 + 600x; \{x \mid 0 < x < 600\}$ B) $A(x) = -x^2 + 600x; \{x \mid 0 < x < 600\}$
 C) $A(x) = -x^2 + 1200x; \{x \mid 0 < x < 1200\}$ D) $A(x) = -x^2 + 600x; \{x \mid 0 < x < 1200\}$

5) A rectangular sign is being designed so that the length of its base, in feet, is 16 feet less than 4 times the height, h . Express the area of the sign as a function of h .

- A) $A(h) = -16h + h^2$ B) $A(h) = 16h - 2h^2$ C) $A(h) = -16h + 4h^2$ D) $A(h) = -16h^2 + 2h$

6) A rectangle that is x feet wide is inscribed in a circle of radius 17 feet. Express the area of the rectangle as a function of x .

- A) $A(x) = x(1156 - x^2)$ B) $A(x) = x^2\sqrt{578 - x^2}$
 C) $A(x) = x\sqrt{1156 - x^2}$ D) $A(x) = x\sqrt{867 - x}$

7) A wire of length $6x$ is bent into the shape of a square. Express the area A of the square as a function of x .

- A) $A(x) = \frac{9}{2}x^2$ B) $A(x) = \frac{1}{16}x^2$ C) $A(x) = \frac{9}{4}x^2$ D) $A(x) = \frac{3}{2}x^2$

SHORT ANSWER. Write the word or phrase that best completes each statement or answers the question.

8) A right triangle has one vertex on the graph of $y = x^2$ at (x, y) , another at the origin, and the third on the (positive) y -axis at $(0, y)$. Express the area A of the triangle as a function of x .

MULTIPLE CHOICE. Choose the one alternative that best completes the statement or answers the question.

9) The figure shown here shows a rectangle inscribed in an isosceles right triangle whose hypotenuse is 8 units long. Express the area A of the rectangle in terms of x .

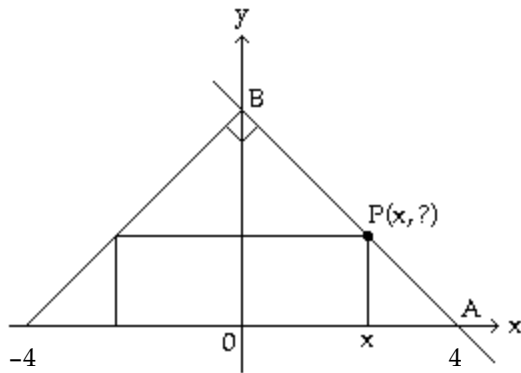

- A) $A(x) = x(4 - x)$ B) $A(x) = 2x^2$ C) $A(x) = 2x(x - 4)$ D) $A(x) = 2x(4 - x)$

SHORT ANSWER. Write the word or phrase that best completes each statement or answers the question.

10) A wire 20 feet long is to be cut into two pieces. One piece will be shaped as a square and the other piece will be shaped as an equilateral triangle. Express the total area A enclosed by the pieces of wire as a function of the length x of a side of the equilateral triangle. What is the domain of A ?

MULTIPLE CHOICE. Choose the one alternative that best completes the statement or answers the question.

- 11) A farmer's silo is the shape of a cylinder with a hemisphere as the roof. If the height of the silo is 101 feet and the radius of the hemisphere is r feet, express the volume of the silo as a function of r .

A) $V(r) = \pi(101 - r)r^3 + \frac{4}{3} \pi r^2$ B) $V(r) = 101 \pi r^2 + \frac{8}{3} \pi r^3$
 C) $V(r) = \pi(101 - r) + \frac{4}{3} \pi r^2$ D) $V(r) = \pi(101 - r)r^2 + \frac{2}{3} \pi r^3$

SHORT ANSWER. Write the word or phrase that best completes each statement or answers the question.

- 12) The volume V of a square-based pyramid with base sides s and height h is $V = \frac{1}{3}s^2h$. If the height is half of the length of a base side, express the volume V as a function of s .

MULTIPLE CHOICE. Choose the one alternative that best completes the statement or answers the question.

- 13) A farmer's silo is the shape of a cylinder with a hemisphere as the roof. If the radius of the hemisphere is 10 feet and the height of the silo is h feet, express the volume of the silo as a function of h .

A) $V(h) = 100 \pi h + \frac{4000}{3} \pi h^2$ B) $V(h) = 100 \pi (h - 10) + \frac{2000}{3} \pi$
 C) $V(h) = 4100 \pi (h - 10) + \frac{500}{7} \pi$ D) $V(h) = 100 \pi (h^2 - 10) + \frac{5000}{3} \pi$

- 14) From a 12-inch by 12-inch piece of metal, squares are cut out of the four corners so that the sides can then be folded up to make a box. Let x represent the length of the sides of the squares, in inches, that are cut out.

Express the volume of the box as a function of x .

A) $V(x) = 2x^3 - 36x^2$ B) $V(x) = 4x^3 - 48x^2$
 C) $V(x) = 2x^3 - 36x^2 + 12x$ D) $V(x) = 4x^3 - 48x^2 + 144x$

- 15) A box with an open top is to be constructed from a rectangular piece of cardboard with dimensions 13 inches by 25 inches by cutting out equal squares of side x at each corner and then folding up the sides as in the figure. Express the volume V of the box as a function of x .

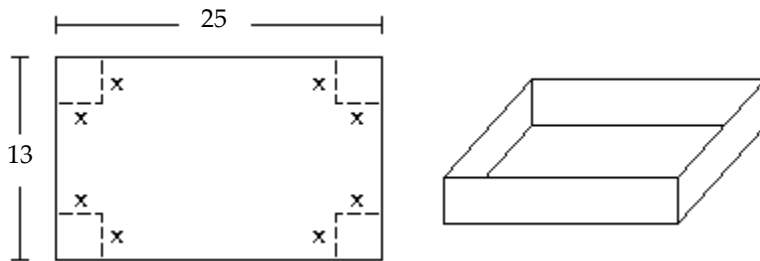

A) $V(x) = (13 - x)(25 - x)$ B) $V(x) = x(13 - 2x)(25 - 2x)$
 C) $V(x) = (13 - 2x)(25 - 2x)$ D) $V(x) = x(13 - x)(25 - x)$

- 16) A rectangular box with volume 341 cubic feet is built with a square base and top. The cost is \$1.50 per square foot for the top and the bottom and \$2.00 per square foot for the sides. Let x represent the length of a side of the base. Express the cost the box as a function of x .

A) $C(x) = 3x^2 + \frac{2728}{x}$ B) $C(x) = 3x^2 + \frac{1364}{x}$ C) $C(x) = 4x + \frac{2728}{x^2}$ D) $C(x) = 2x^2 + \frac{2728}{x}$

17) The price p and the quantity x sold of a certain product obey the demand equation:

$$p = -\frac{1}{9}x + 100, \{x | 0 \leq x \leq 900\}$$

What is the revenue to the nearest dollar when 400 units are sold?

- A) \$130,000 B) \$50,000 C) \$22,222 D) \$57,778

18) Let $P = (x, y)$ be a point on the graph of $y = \sqrt{x}$. Express the distance d from P to the point $(1, 0)$ as a function of x .

- A) $d(x) = x^2 + 2x + 2$ B) $d(x) = \sqrt{x^2 - x + 1}$
C) $d(x) = \sqrt{x^2 + 2x + 2}$ D) $d(x) = x^2 - x + 1$

SHORT ANSWER. Write the word or phrase that best completes each statement or answers the question.

19) The price p and x , the quantity of a certain product sold, obey the demand equation

$$p = -\frac{1}{10}x + 100, \{x | 0 \leq x \leq 1000\}$$

- a) Express the revenue R as a function of x .
 - b) What is the revenue if 450 units are sold?
 - c) Graph the revenue function using a graphing utility.
 - d) What quantity x maximizes revenue? What is the maximum revenue?
 - e) What price should the company charge to maximize revenue?
- 20) Two boats leave a dock at the same time. One boat is headed directly east at a constant speed of 35 knots (nautical miles per hour), and the other is headed directly south at a constant speed of 22 knots. Express the distance d between the boats as a function of the time t .

MULTIPLE CHOICE. Choose the one alternative that best completes the statement or answers the question.

21) A rocket is shot straight up in the air from the ground at a rate of 67 feet per second. The rocket is tracked by a range finder that is 436 feet from the launch pad. Let d represent the distance from the rocket to the range finder and t represent the time, in seconds, since "blastoff". Express d as a function of t .

- A) $d(t) = \sqrt{436^2 + (67t)^2}$ B) $d(t) = 436^2 + (67t)^2$
C) $d(t) = 436 + 67t^2$ D) $d(t) = \sqrt{67^2 + (436t)^2}$

Ch. 2 Functions and Their Graphs

Answer Key

2.1 Functions

1 Determine Whether a Relation Represents a Function

- 1) B
- 2) C
- 3) B
- 4) B
- 5) C
- 6) B
- 7) A
- 8) A
- 9) A
- 10) A
- 11) B
- 12) B
- 13) B
- 14) B
- 15) A
- 16) A
- 17) B
- 18) A
- 19) A

2 Find the Value of a Function

- 1) D
- 2) B
- 3) B
- 4) C
- 5) D
- 6) C
- 7) B
- 8) B
- 9) A
- 10) B
- 11) A
- 12) C
- 13) A
- 14) D
- 15) B
- 16) B
- 17) C
- 18) A
- 19) D
- 20) D
- 21) D
- 22) B

3 Find the Domain of a Function Defined by an Equation

- 1) A
- 2) D
- 3) C
- 4) C
- 5) C
- 6) D

7) D

4 Form the Sum, Difference, Product, and Quotient of Two Functions

1) C

2) A

3) B

4) D

5) C

6) A

7) B

8) B

9) C

10) B

11) A

12) B

13) B

14) D

15) B

16) C

17) C

18) D

19) B

20) D

21) A

22) D

23) B

24) C

25) D

26) A

27) D

28) B

2.2 The Graph of a Function

1 Identify the Graph of a Function

1) D

2) C

3) A

4) B

5) D

6) C

7) D

2 Obtain Information from or about the Graph of a Function

1) B

2) A

3) B

4) C

5) C

6) A

7) C

8) D

9) A

10) D

11) C

12) D

13) A

14) B

- 15) A
- 16) A
- 17) D
- 18) B
- 19) A
- 20) B
- 21) D
- 22) D
- 23) D
- 24) D
- 25) A
- 26) A
- 27) D

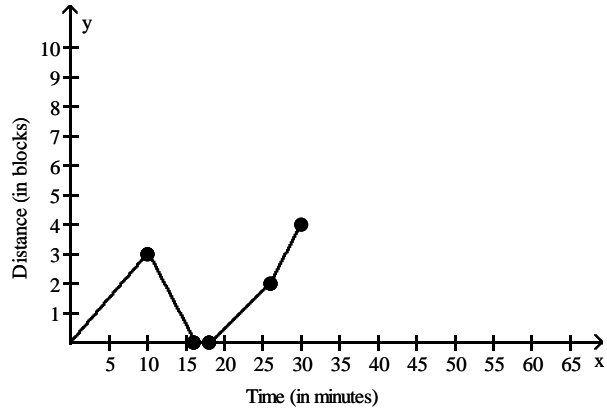

28)

- 29) A
- 30) B

2.3 Properties of Functions

1 Determine Even and Odd Functions from a Graph

- 1) A
- 2) A
- 3) C
- 4) C
- 5) B
- 6) B
- 7) B
- 8) A

2 Identify Even and Odd Functions from the Equation

- 1) B
- 2) A
- 3) A
- 4) C
- 5) B
- 6) C
- 7) A
- 8) A
- 9) B
- 10) B
- 11) B

3 Use a Graph to Determine Where a Function is Increasing, Decreasing, or Constant

- 1) C
- 2) A
- 3) B

- 4) C
- 5) A
- 6) C
- 7) A
- 8) C
- 9) C
- 10) C
- 11) A
- 12) B
- 13) C
- 14) A
- 15) A
- 16) A

4 Use a Graph to Locate Local Maxima and Local Minima

- 1) B
- 2) B
- 3) D
- 4) C
- 5) B
- 6) B

5 Use a Graph to Locate the Absolute Maximum and the Absolute Minimum

- 1) D
- 2) A
- 3) B
- 4) D

6 Use Graphing Utility to Approximate Local Maxima/Minima & Determine Where Func is Increasing/Decreasing

- 1) B
- 2) A
- 3) A
- 4) C
- 5) C
- 6) B
- 7) D
- 8) D
- 9) D
- 10) D
- 11) A
- 12) A
- 13) D
- 14) D
- 15) A
- 16) B

7 Find the Average Rate of Change of a Function

- 1) C
- 2) D
- 3) D
- 4) D
- 5) B
- 6) D
- 7) C
- 8) A
- 9) A
- 10) B
- 11) A

- 12) A
- 13) A
- 14) B
- 15) A
- 16) C
- 17) C
- 18) C
- 19) D
- 20) A

2.4 Library of Functions; Piecewise-defined Functions

1 Graph the Functions Listed in the Library of Functions

- 1) C
- 2) A
- 3) B
- 4) C
- 5) A
- 6) D
- 7) A
- 8) C
- 9) A
- 10) C
- 11) C
- 12) B
- 13) D
- 14) A
- 15) C
- 16) B

2 Graph Piecewise-defined Functions

- 1) B
- 2) D
- 3) B
- 4) D
- 5) C
- 6) A
- 7) C
- 8) A
- 9) D
- 10) D
- 11) C
- 12) C
- 13) A
- 14) B
- 15) D
- 16) A
- 17) B
- 18) B
- 19) \$25.52

\$42.69

$$C(x) = \begin{cases} 8.8 + 0.6686x & \text{if } 0 \leq x \leq 25 \\ 4.0475 + 0.8587x & \text{if } x > 25 \end{cases}$$

- 20) \$39.70

\$49.69

$$C(x) = \begin{cases} 4.93 + 0.11589x & \text{if } 0 \leq x \leq 300 \\ -0.266 + 0.13321x & \text{if } x > 300 \end{cases}$$

- 21) \$18.00
- \$24.25
- \$65.50
- 22) 6.0°C
- 23) \$27.50
- \$32.50;

$$C(x) = \begin{cases} 20 & \text{if } 0 \leq x \leq 100 \\ 12.5 + 0.075x & \text{if } 100 < x \leq 200 \\ 7.5 + 0.1x & \text{if } x > 200 \end{cases}$$

2.5 Graphing Techniques: Transformations

1 Graph Functions Using Vertical and Horizontal Shifts

- 1) D
- 2) D
- 3) C
- 4) D
- 5) C
- 6) D
- 7) A
- 8) A
- 9) B
- 10) C
- 11) C
- 12) C
- 13) D
- 14) C
- 15) A
- 16) C
- 17) B
- 18) C
- 19) C
- 20) A
- 21) D
- 22) D
- 23) A
- 24) C
- 25) A
- 26) D
- 27) C
- 28) B
- 29) B
- 30) A
- 31) A
- 32) A
- 33) A
- 34) B
- 35) B
- 36) D

2 Graph Functions Using Compressions and Stretches

- 1) D
- 2) C
- 3) A
- 4) C
- 5) A
- 6) D

- 7) B
- 8) C
- 9) B
- 10) B
- 11) D
- 12) B
- 13) A
- 14) C
- 15) D
- 16) B
- 17) A
- 18) D

3 Graph Functions Using Reflections about the x-Axis or y-Axis

- 1) B
- 2) A
- 3) D
- 4) D
- 5) B
- 6) B
- 7) D
- 8) A
- 9) C
- 10) C
- 11) A
- 12) B
- 13) B
- 14) C
- 15) B
- 16) B
- 17) D
- 18) B
- 19) D

2.6 Mathematical Models: Building Functions

1 Build and Analyze Functions

- 1) B
- 2) C
- 3) C
- 4) B
- 5) C
- 6) C
- 7) C

8) $A(x) = \frac{1}{2}x^3$

- 9) D

10) $A(x) = \frac{4\sqrt{3} + 9}{16}x^2 - \frac{15}{2}x + 25; \{x | 0 \leq x \leq \frac{20}{3}\}$

- 11) D

12) $V(s) = \frac{1}{6}s^3$

- 13) B
- 14) D
- 15) B
- 16) A

17) C

18) B

19) a. $R(x) = -\frac{1}{10}x^2 + 100x$

b. $R(450) = \$24,750.00$

c.

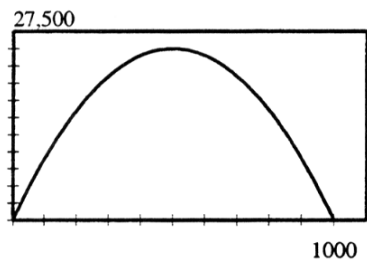

d. 500; \$25,000.00

e. \$50.00

20) $d(t) = \sqrt{1709t}$

21) A