

## Chapter 001 - Programmable Logic Controllers (PLCs): An Overview

### True / False Questions

1. The number and type of I/Os cannot be changed in a fixed PLC.

True False

2. In a PLC system, there is a physical connection between field input devices and output devices.

True False

3. The scan time is the time required for one complete execution of the user program.

True False

4. The input/output system forms the interfaces through which field devices are connected to the controller.

True False

5. Plug-in compartments allow I/O modules to be easily connected and replaced.

True False

6. A personal computer communicates with the PLC processor via a serial or parallel data communications link.

True False

7. The programming device must be connected to the controller to run the program.

True False

## Chapter 001 - Programmable Logic Controllers (PLCs): An Overview

8. PLC systems usually require as much space in an enclosure as equivalent hardwired relay systems.

True False

9. A PLC is basically a computer designed for use in electrical control applications.

True False

10. The programmable controller operates in real time.

True False

11. One disadvantage of modular I/O is its lack of flexibility.

True False

12. A PLC power supply module does not normally supply power to the field devices.

True False

13. Removing the programming device from the PLC will not affect the operation of the user program.

True False

14. Software installed and run on a personal computer can be used to write a PLC program.

True False

15. The instruction set for a particular PLC lists the types of instructions supported.

True False

## Chapter 001 - Programmable Logic Controllers (PLCs): An Overview

16. When dealing with PLC memory, one K of memory represents 1024.

True False

17. The number of I/O points does not affect the memory size required for a PLC installation.

True False

### Multiple Choice Questions

18. PLCs were originally designed as replacements for:

- A. microcomputers.
- B. relay control panels.
- C. analog controllers.
- D. digital controllers.

19. Basically, the function of a PLC is to:

- A. amplify various weak signal sources.
- B. control a high voltage output with a low voltage input.
- C. control the speed of motors.
- D. make logical decisions and control outputs based on them.

20. Modifying relay-type process control circuits usually involves changing the:

- A. circuit wiring.
- B. input circuit modules.
- C. output circuit modules.
- D. circuit operating voltage levels.

## Chapter 001 - Programmable Logic Controllers (PLCs): An Overview

21. Which of the following is *not* an advantage that PLCs offer over the conventional relay-type of control system?
- A. Smaller size
  - B. Less expensive
  - C. Higher current capacity
  - D. More reliable
22. The main difference between a PLC and relay control system is that:
- A. different types of input devices are used.
  - B. different types of output devices are used.
  - C. different input and output voltage levels are used.
  - D. one uses hardwired relay control logic and the other uses programmed instructions.
23. The central processing unit:
- A. looks at the inputs, makes the decisions based on the program, and sets the outputs.
  - B. looks at the outputs, makes the decisions based on the program, and sets the inputs.
  - C. serves only to store the program in memory.
  - D. serves only to supply power to the backplane.
24. PLC proprietary architecture:
- A. is the opposite to open architecture.
  - B. makes it more difficult to connect to devices made by other PLC manufacturers.
  - C. does not allow programs to be interchanged between different PLC manufacturers.
  - D. All of the above.
25. The output interface module connects to:
- A. sensing devices such as switches or pushbuttons.
  - B. load devices such as lamps or solenoids.
  - C. a programming device such as a computer.
  - D. All of the above.

## Chapter 001 - Programmable Logic Controllers (PLCs): An Overview

26. *Field* or *real-world* devices refer to:

- A. input devices only.
- B. output devices only.
- C. load devices only.
- D. all devices that are physically wired to the PLC.

27. The power required to operate the logic circuits of the processor unit is typically:

- A. low voltage ac.
- B. high voltage ac.
- C. low voltage dc.
- D. high voltage dc.

28. The control plan stored in the PLC is called:

- A. a program.
- B. a Boolean ladder.
- C. FORTRAN.
- D. a microprocessor.

29. The programming device:

- A. is used to enter the program into the memory of the processor.
- B. is commonly a personal computer.
- C. can be a hand-held device.
- D. All of the above.

30. The programming device must be connected to the controller:

- A. at all times.
- B. when entering a program.
- C. when monitoring a program.
- D. both b and c.

## Chapter 001 - Programmable Logic Controllers (PLCs): An Overview

31. The symbol  in a ladder logic diagram:
- A. can be thought of as a normally open contact.
  - B. represents a capacitor.
  - C. is always at logic 0.
  - D. is always at logic 1.

32. The symbol  in a ladder logic diagram represents a:
- A. set of normally closed contacts.
  - B. virtual relay coil.
  - C. seal-in contact.
  - D. field input sensing device.

33. When a field device contact connected to the input module closes:
- A. a logic 1 is recorded in the memory location of the coil with the same address.
  - B. a logic 1 is recorded in the memory location of the contact with the same address.
  - C. a logic 0 is recorded in the memory location of the coil with the same address.
  - D. None of these are correct.

34. At the start of the PLC scan the:
- A. status of all inputs are read.
  - B. status of all outputs are updated.
  - C. program is executed.
  - D. diagnostics and communications tasks are executed.

35. The scan time is the time required:
- A. to record the status of all input devices.
  - B. to record the status of all output devices.
  - C. to execute one cycle of the total program.
  - D. for the information to pass from input to output.

## Chapter 001 - Programmable Logic Controllers (PLCs): An Overview

36. Unlike personal computers, PLCs are:
- A. equipped with input and output modules.
  - B. equipped with a control programming language.
  - C. designed for the industrial environment.
  - D. All of the above.
37. A human machine interface (HMI)
- A. allows the user to monitor a process.
  - B. allows the user to control a process.
  - C. can provide a graphical representation of a process.
  - D. All of the above.
38. Programmable logic controllers are categorized according to the
- A. number of I/O points.
  - B. current rating of I/O modules.
  - C. power rating of the I/O modules.
  - D. cost of the I/O modules.

## Chapter 001 - Programmable Logic Controllers (PLCs): An Overview

39. Block No.1 of the PLC block diagram represents the:

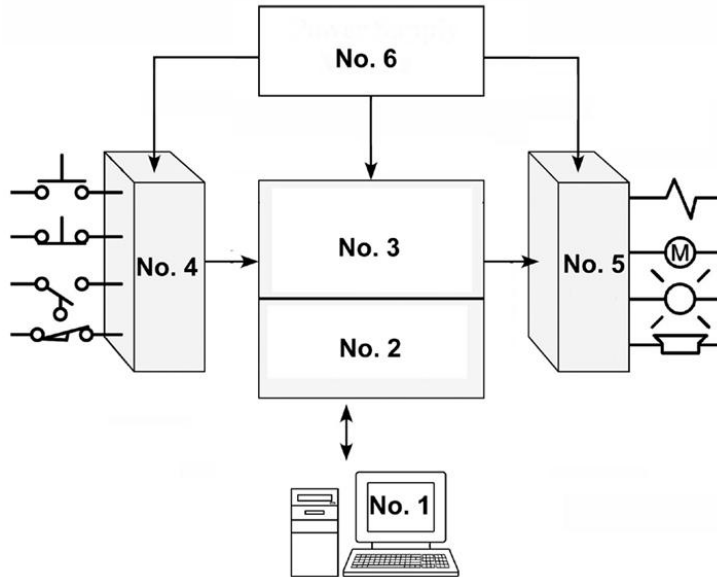

- A. CPU unit.
- B. programming device.
- C. input module.
- D. output module.



## Chapter 001 - Programmable Logic Controllers (PLCs): An Overview

40. Block No. 2 of the PLC block diagram represents the:

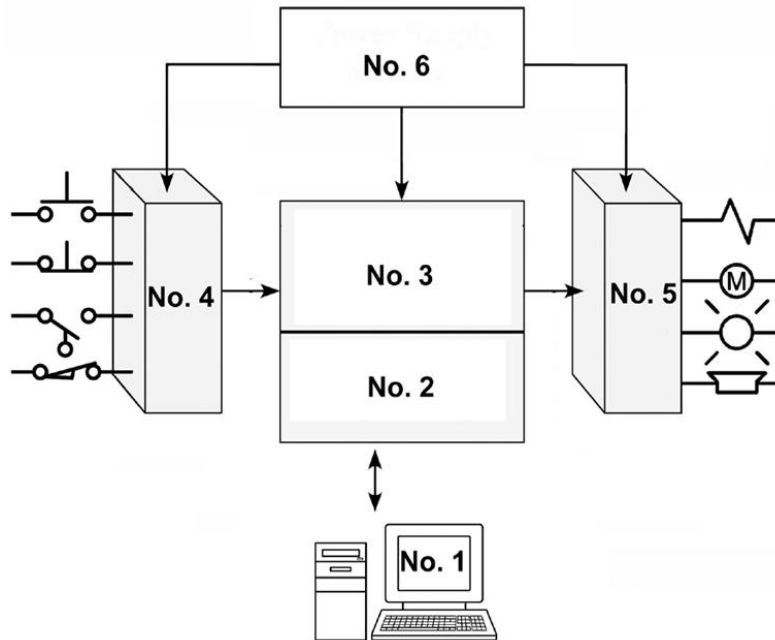

- A. memory.
- B. programming device.
- C. input module.
- D. power supply module.

## Chapter 001 - Programmable Logic Controllers (PLCs): An Overview

41. Block No. 3 of the PLC block diagram represents the:

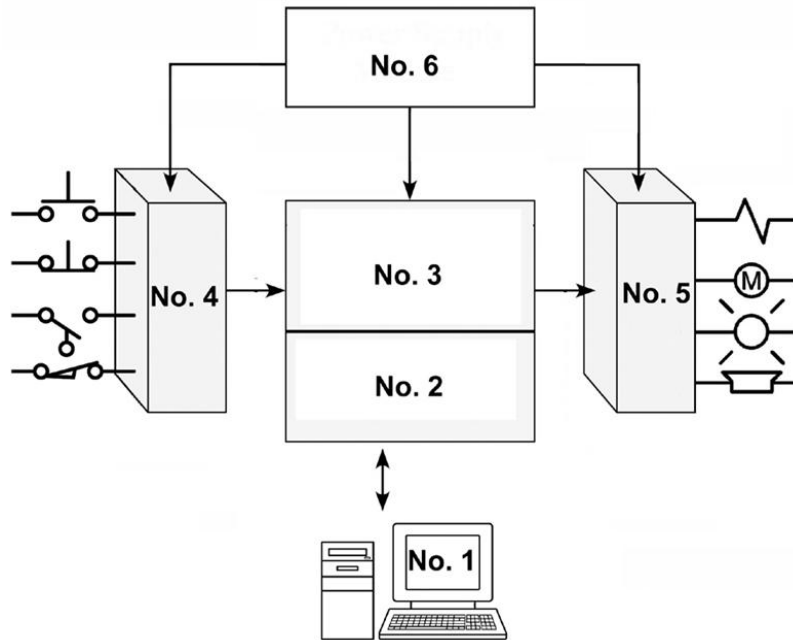

- A. CPU unit.
- B. programming device.
- C. input module.
- D. output module.

## Chapter 001 - Programmable Logic Controllers (PLCs): An Overview

42. Block No. 4 of the PLC block diagram represents the:

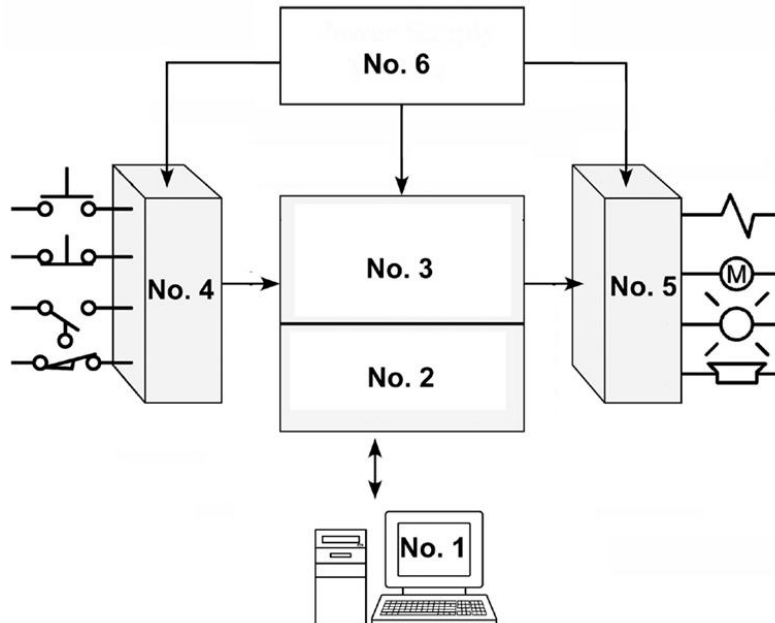

- A. memory.
- B. programming device.
- C. input module.
- D. CPU.

## Chapter 001 - Programmable Logic Controllers (PLCs): An Overview

43. Block No. 5 of the PLC block diagram represents the:

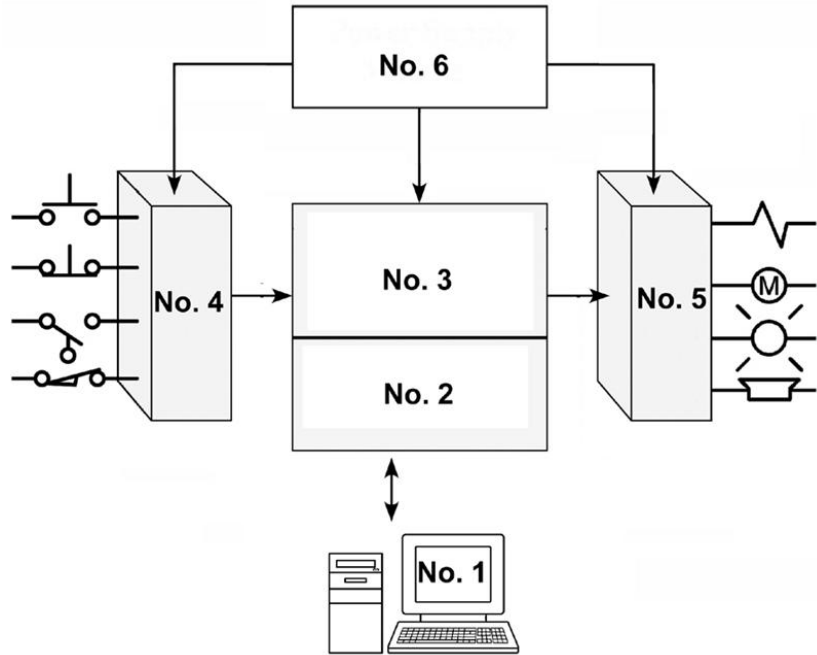

- A. memory.
- B. power supply module.
- C. input module.
- D. output module.

## Chapter 001 - Programmable Logic Controllers (PLCs): An Overview

44. Block No. 6 of the PLC block diagram represents the:

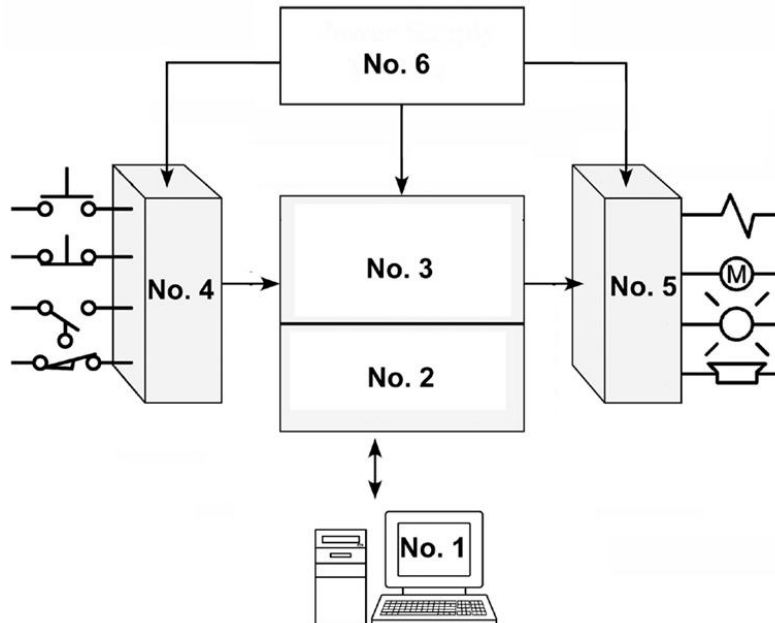

- A. processor module.
- B. power supply module.
- C. input module.
- D. output module.

# Chapter 001 - Programmable Logic Controllers (PLCs): An Overview

45. The diagram shown is a:

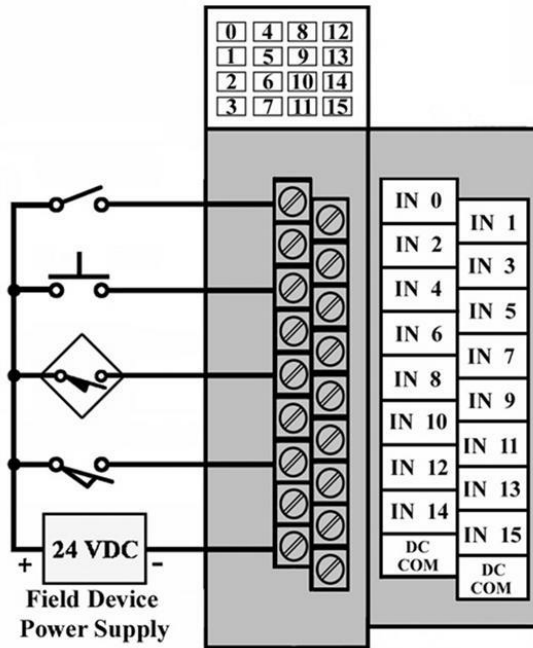

- A. relay schematic.
- B. ladder logic program.
- C. input module wiring.
- D. output module wiring.

## Chapter 001 - Programmable Logic Controllers (PLCs): An Overview

46. The voltage that would be present between the DC common and terminal 4 with the pushbutton open would be approximately:

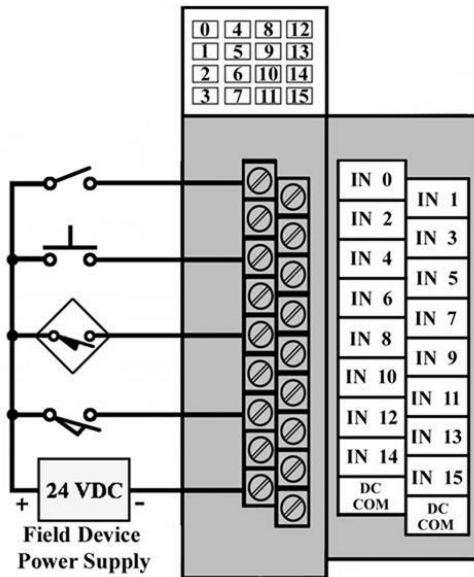

- A. 0 volts.
- B. 6 volts.
- C. 12 volts.
- D. 24 volts.

## Chapter 001 - Programmable Logic Controllers (PLCs): An Overview

47. The voltage that would be present between the DC common and terminal 4 with the pushbutton closed would be approximately:

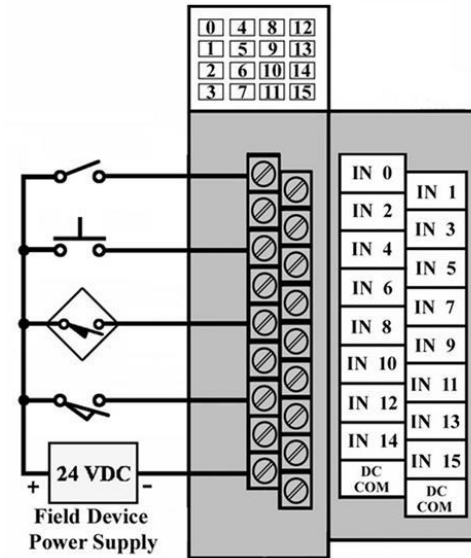

- A. 0 volts.
- B. 6 volts.
- C. 12 volts.
- D. 24 volts.



## Chapter 001 - Programmable Logic Controllers (PLCs): An Overview

48. The devices connected to the terminals would be classified as:

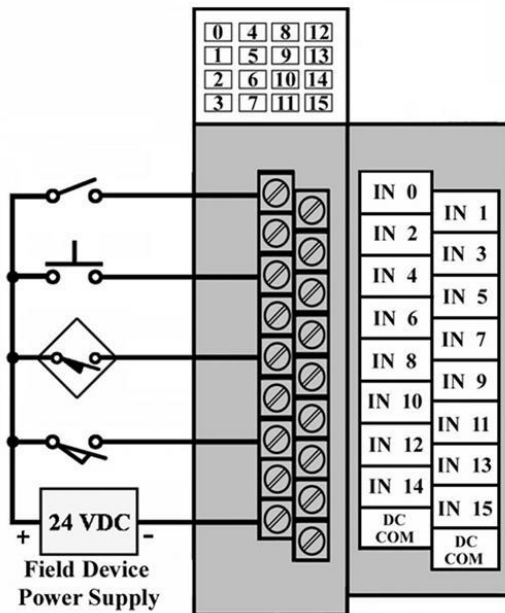

- A. field input devices.
- B. internal input instructions.
- C. field output devices.
- D. internal output instructions

## Chapter 001 - Programmable Logic Controllers (PLCs): An Overview

49. The diagram shown is that of a

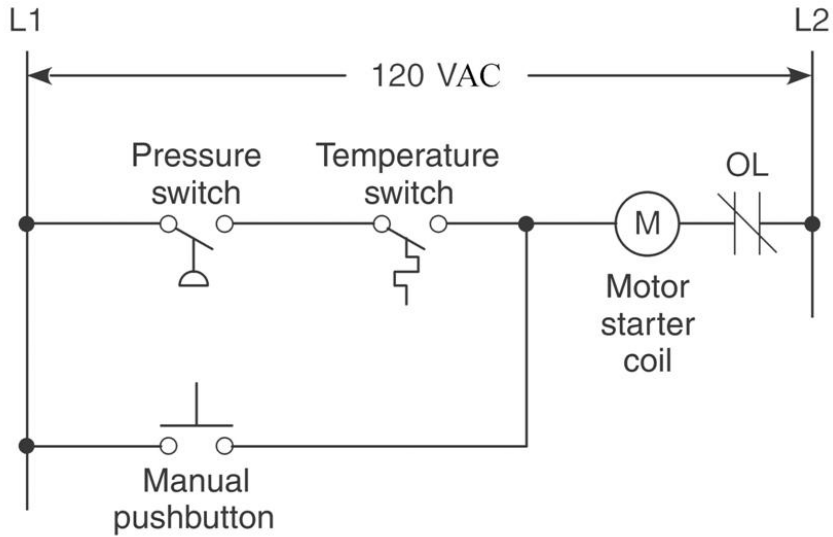

- A. hardwired relay schematic.
- B. ladder logic program.
- C. input module schematic.
- D. output module schematic.

## Chapter 001 - Programmable Logic Controllers (PLCs): An Overview

50. In order to energize the starter coil:

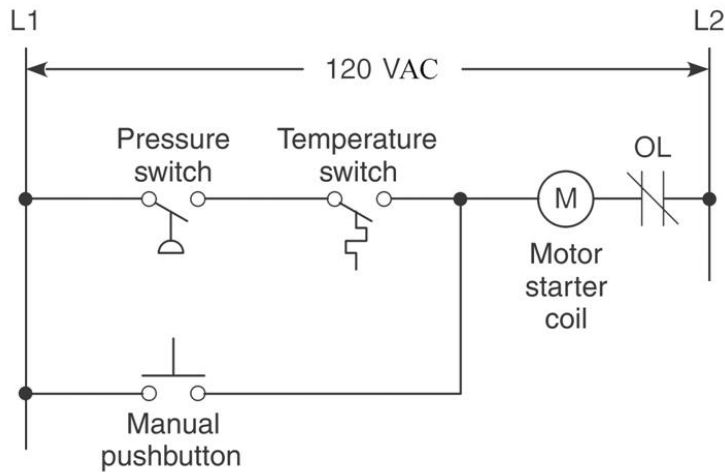

- A. the pressure switch, and the temperature switch, and the manual pushbutton must be closed.
- B. the pressure switch, or the temperature switch, or the manual pushbutton must be closed.
- C. the pressure switch, and the temperature switch, or the manual pushbutton must be closed.
- D. All of the above.

51. The diagram shown is that of a:

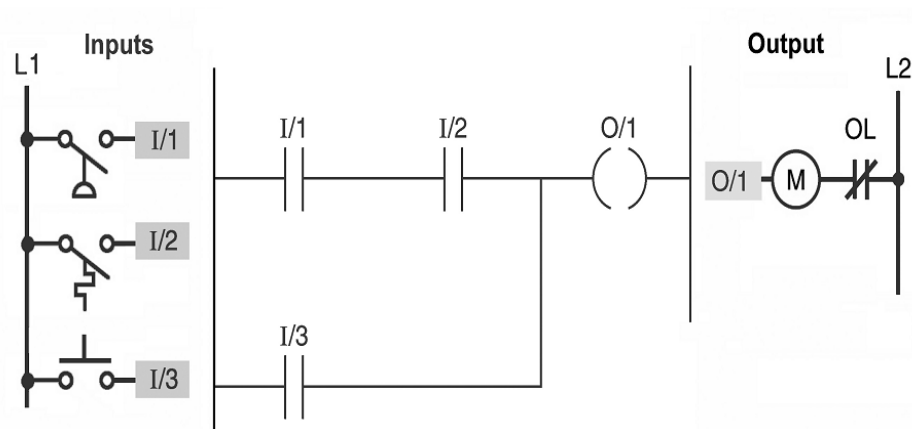

- A. relay schematic.
- B. ladder logic program.
- C. input module wiring diagram.
- D. output module wiring diagram.

## Chapter 001 - Programmable Logic Controllers (PLCs): An Overview

52. For there to be a continuous logic path from left to right across the rung:

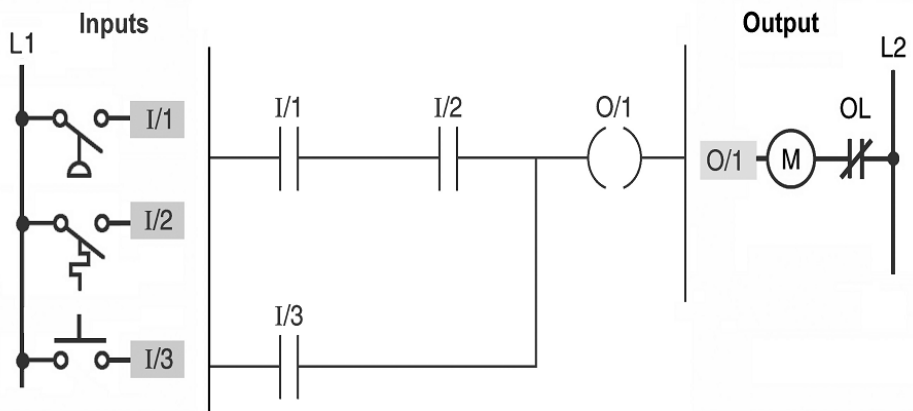

- A. I/1, I/2, and I/3 must all be at logic 1.
- B. I/1, I/2, and I/3 must all be at logic 0.
- C. I/1 and I/2 or I/3 must be at logic 1.
- D. I/1 and I/2 or I/3 will be at logic 0.

53. The PLC power supply module normally is rated to provide the power for:

- A. all field devices.
- B. input field devices only.
- C. output field devices only.
- D. PLC backplane and I/O modules.

54. Which module of the PLC is responsible for performing logical operations?

- A. Processor
- B. Input
- C. Output
- D. Power supply

## Chapter 001 - Programmable Logic Controllers (PLCs): An Overview

55. Which module of the PLC connects directly to field devices such as pilot lights, motor starters, and solenoids?

- A. Input
- B. Output
- C. Power supply
- D. Memory

56. I/Os are typical of small PLCs that come in one package with no separate removable units.

- A. Fixed
- B. Modular
- C. Digital
- D. Analog

57. PLC software that runs on a personal computer can be used to:

- A. write a PLC program.
- B. document a PLC program.
- C. monitor the control process.
- D. All of the above.

58. A control management PLC application normally requires a:

- A. micro-size PLC.
- B. small-size PLC.
- C. medium-size PLC.
- D. large-size PLC.

59. Which of the following is *not* a factor effecting the memory size needed for a particular PLC installation?

- A. Voltage rating of field devices
- B. Number of I/O points
- C. Size of control program
- D. Supervisory functions

## Chapter 001 - Programmable Logic Controllers (PLCs): An Overview **Key**

### **True / False Questions**

1. (p. 4) The number and type of I/Os cannot be changed in a fixed PLC.

**TRUE**

*PTS: 1*

2. (p. 9) In a PLC system, there is a physical connection between field input devices and output devices.

**TRUE**

*PTS: 1*

3. (p. 10) The scan time is the time required for one complete execution of the user program.

**TRUE**

*PTS: 1*

4. (p. 6) The input/output system forms the interfaces through which field devices are connected to the controller.

**TRUE**

*PTS: 1*

5. (p. 4) Plug-in compartments allow I/O modules to be easily connected and replaced.

**TRUE**

*PTS: 1*

## Chapter 001 - Programmable Logic Controllers (PLCs): An Overview **Key**

6. (p. 7) A personal computer communicates with the PLC processor via a serial or parallel data communications link.

**TRUE**

*PTS: 1*

7. (p. 7) The programming device must be connected to the controller to run the program.

**FALSE**

*PTS: 1*

8. (p. 2) PLC systems usually require as much space in an enclosure as equivalent hardwired relay systems.

**FALSE**

*PTS: 1*

9. (p. 2) A PLC is basically a computer designed for use in electrical control applications.

**TRUE**

*PTS: 1*

10. (p. 3) The programmable controller operates in real time.

**TRUE**

*PTS: 1*

11. (p. 4) One disadvantage of modular I/O is its lack of flexibility.

**FALSE**

*PTS: 1*

## Chapter 001 - Programmable Logic Controllers (PLCs): An Overview **Key**

12. (p. 5) A PLC power supply module does not normally supply power to the field devices.

**TRUE**

*PTS: 1*

13. (p. 7) Removing the programming device from the PLC will not affect the operation of the user program.

**TRUE**

*PTS: 1*

14. (p. 12) Software installed and run on a personal computer can be used to write a PLC program.

**TRUE**

*PTS: 1*

15. (p. 14) The instruction set for a particular PLC lists the types of instructions supported.

**TRUE**

*PTS: 1*

16. (p. 13) When dealing with PLC memory, one K of memory represents 1024.

**TRUE**

*PTS: 1*



## Chapter 001 - Programmable Logic Controllers (PLCs): An Overview **Key**

17. (p. 14) The number of I/O points does not affect the memory size required for a PLC installation.

**FALSE**

*PTS: 1*

### **Multiple Choice Questions**

18. (p. 2) PLCs were originally designed as replacements for:

- A. microcomputers.
- B.** relay control panels.
- C. analog controllers.
- D. digital controllers.

*PTS: 1*

19. (p. 2) Basically, the function of a PLC is to:

- A. amplify various weak signal sources.
- B. control a high voltage output with a low voltage input.
- C. control the speed of motors.
- D.** make logical decisions and control outputs based on them.

*PTS: 1*

20. (p. 2) Modifying relay-type process control circuits usually involves changing the:

- A.** circuit wiring.
- B. input circuit modules.
- C. output circuit modules.
- D. circuit operating voltage levels.

*PTS: 1*

## Chapter 001 - Programmable Logic Controllers (PLCs): An Overview **Key**

21. (p. 2-3) Which of the following is *not* an advantage that PLCs offer over the conventional relay-type of control system?

- A. Smaller size
- B. Less expensive
- C. Higher current capacity**
- D. More reliable

*PTS: 1*

22. (p. 2) The main difference between a PLC and relay control system is that:

- A. different types of input devices are used.
- B. different types of output devices are used.
- C. different input and output voltage levels are used.
- D. one uses hardwired relay control logic and the other uses programmed instructions.**

*PTS: 1*

23. (p. 5) The central processing unit:

- A. looks at the inputs, makes the decisions based on the program, and sets the outputs.**
- B. looks at the outputs, makes the decisions based on the program, and sets the inputs.
- C. serves only to store the program in memory.
- D. serves only to supply power to the backplane.

*PTS: 1*

24. (p. 4) PLC proprietary architecture:

- A. is the opposite to open architecture.
- B. makes it more difficult to connect to devices made by other PLC manufacturers.
- C. does not allow programs to be interchanged between different PLC manufacturers.
- D. All of the above.**

*PTS: 1*

## Chapter 001 - Programmable Logic Controllers (PLCs): An Overview **Key**

25. (p. 3) The output interface module connects to:
- A. sensing devices such as switches or pushbuttons.
  - B.** load devices such as lamps or solenoids.
  - C. a programming device such as a computer.
  - D. All of the above.

PTS: 1

26. (p. 6) *Field* or *real-world* devices refer to:
- A. input devices only.
  - B. output devices only.
  - C. load devices only.
  - D.** all devices that are physically wired to the PLC.

PTS: 1

27. (p. 4-5) The power required to operate the logic circuits of the processor unit is typically:
- A. low voltage ac.
  - B. high voltage ac.
  - C.** low voltage dc.
  - D. high voltage dc.

PTS: 1

28. (p. 2) The control plan stored in the PLC is called:
- A.** a program.
  - B. a Boolean ladder.
  - C. FORTRAN.
  - D. a microprocessor.

PTS: 1

## Chapter 001 - Programmable Logic Controllers (PLCs): An Overview **Key**

29. (p. 7) The programming device:

- A. is used to enter the program into the memory of the processor.
- B. is commonly a personal computer.
- C. can be a hand-held device.
- D.** All of the above.

*PTS: 1*

30. (p. 4) The programming device must be connected to the controller:

- A. at all times.
- B. when entering a program.
- C. when monitoring a program.
- D.** both b and c.

*PTS: 1*

31. (p. 9) The symbol  in a ladder logic diagram:

- A.** can be thought of as a normally open contact.
- B. represents a capacitor.
- C. is always at logic 0.
- D. is always at logic 1.

*PTS: 1*

32. (p. 9) The symbol  in a ladder logic diagram represents a:

- A. set of normally closed contacts.
- B.** virtual relay coil.
- C. seal-in contact.
- D. field input sensing device.

*PTS: 1*

## Chapter 001 - Programmable Logic Controllers (PLCs): An Overview **Key**

33. (p. 9) When a field device contact connected to the input module closes:
- A. a logic 1 is recorded in the memory location of the coil with the same address.
  - B.** a logic 1 is recorded in the memory location of the contact with the same address.
  - C. a logic 0 is recorded in the memory location of the coil with the same address.
  - D. None of these are correct.

*PTS: 1*

34. (p. 5) At the start of the PLC scan the:
- A.** status of all inputs are read.
  - B. status of all outputs are updated.
  - C. program is executed.
  - D. diagnostics and communications tasks are executed.

*PTS: 1*

35. (p. 10) The scan time is the time required:
- A. to record the status of all input devices.
  - B. to record the status of all output devices.
  - C.** to execute one cycle of the total program.
  - D. for the information to pass from input to output.

*PTS: 1*

36. (p. 2) Unlike personal computers, PLCs are:
- A. equipped with input and output modules.
  - B. equipped with a control programming language.
  - C. designed for the industrial environment.
  - D.** All of the above.

*PTS: 1*

## Chapter 001 - Programmable Logic Controllers (PLCs): An Overview **Key**

37. (p. 12) A human machine interface (HMI)

- A. allows the user to monitor a process.
- B. allows the user to control a process.
- C. can provide a graphical representation of a process.
- D.** All of the above.

*PTS: 1*

38. (p. 12) Programmable logic controllers are categorized according to the

- A.** number of I/O points.
- B. current rating of I/O modules.
- C. power rating of the I/O modules.
- D. cost of the I/O modules.

*PTS: 1*

Chapter 001 - Programmable Logic Controllers (PLCs): An Overview **Key**

39. (p. 5) Block No.1 of the PLC block diagram represents the:

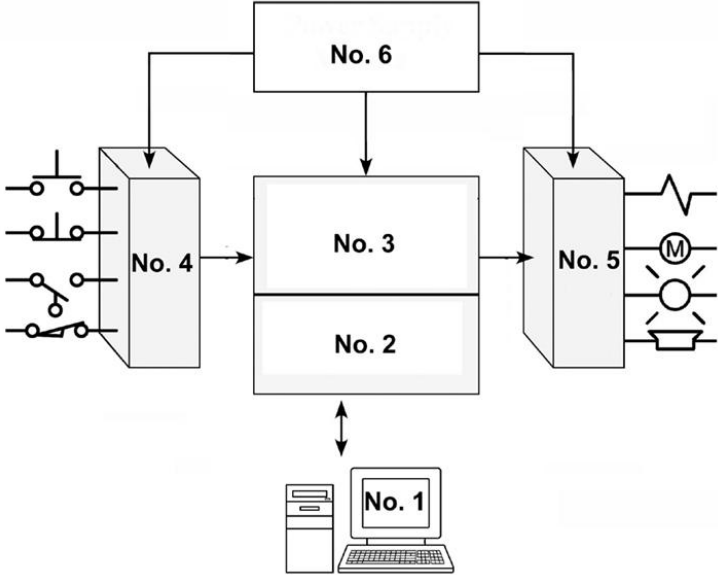

- A. CPU unit.
- B.** programming device.
- C. input module.
- D. output module.

PTS: 1

## Chapter 001 - Programmable Logic Controllers (PLCs): An Overview **Key**

40. (p. 5) Block No. 2 of the PLC block diagram represents the:

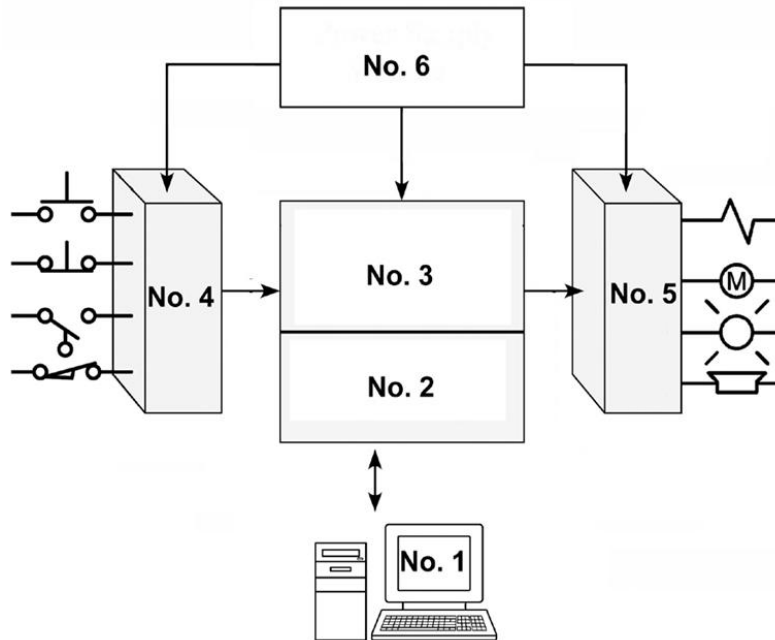

- A.** memory.
- B. programming device.
- C. input module.
- D. power supply module.

*PTS: 1*



# Chapter 001 - Programmable Logic Controllers (PLCs): An Overview Key

41. (p. 5) Block No. 3 of the PLC block diagram represents the:

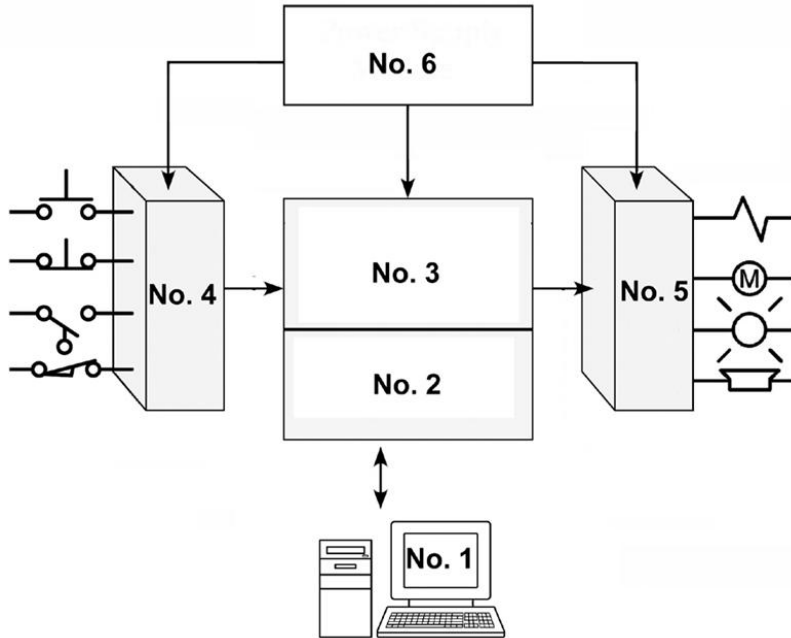

- A. CPU unit.
- B. programming device.
- C. input module.
- D. output module.

PTS: 1

# Chapter 001 - Programmable Logic Controllers (PLCs): An Overview Key

42. (p. 5) Block No. 4 of the PLC block diagram represents the:

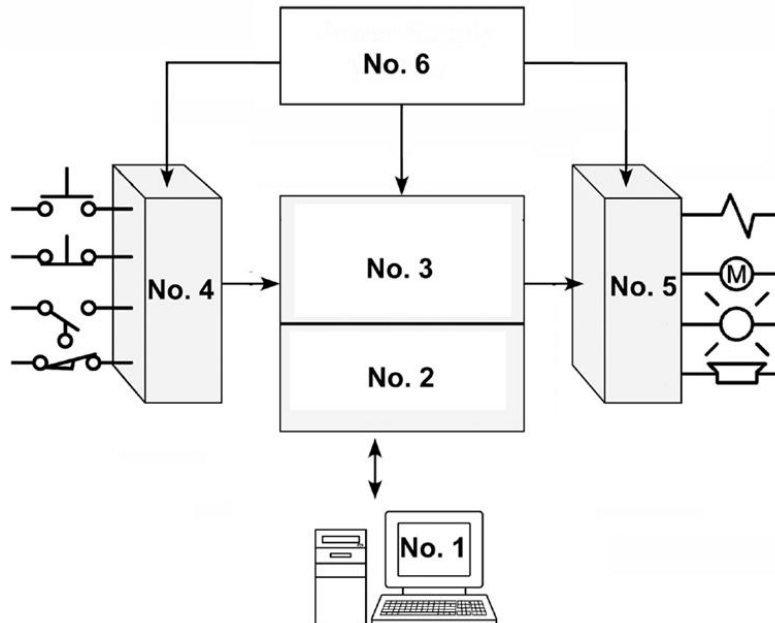

- A. memory.
- B. programming device.
- C. input module.**
- D. CPU.

PTS: 1

# Chapter 001 - Programmable Logic Controllers (PLCs): An Overview Key

43. (p. 5) Block No. 5 of the PLC block diagram represents the:

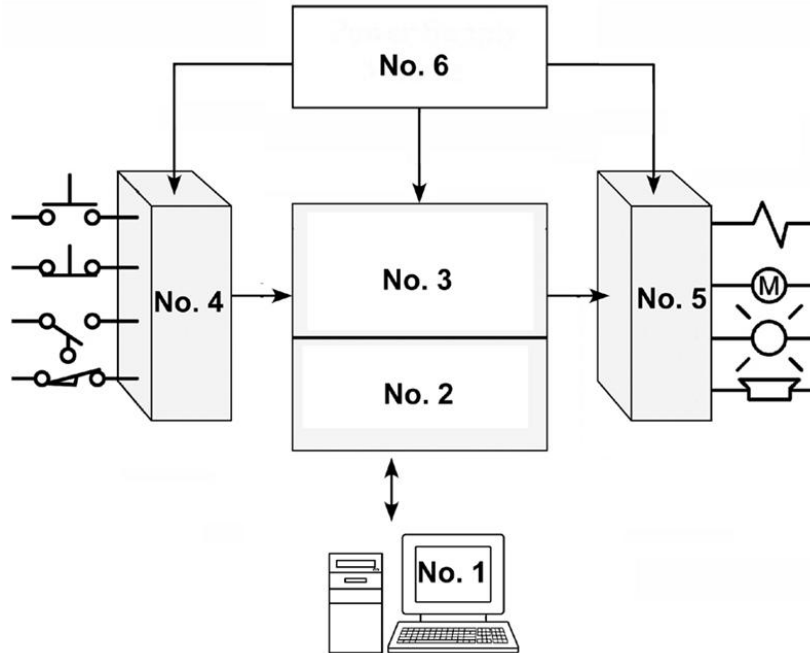

- A. memory.
- B. power supply module.
- C. input module.
- D.** output module.

PTS: 1

## Chapter 001 - Programmable Logic Controllers (PLCs): An Overview **Key**

44. (p. 5) Block No. 6 of the PLC block diagram represents the:

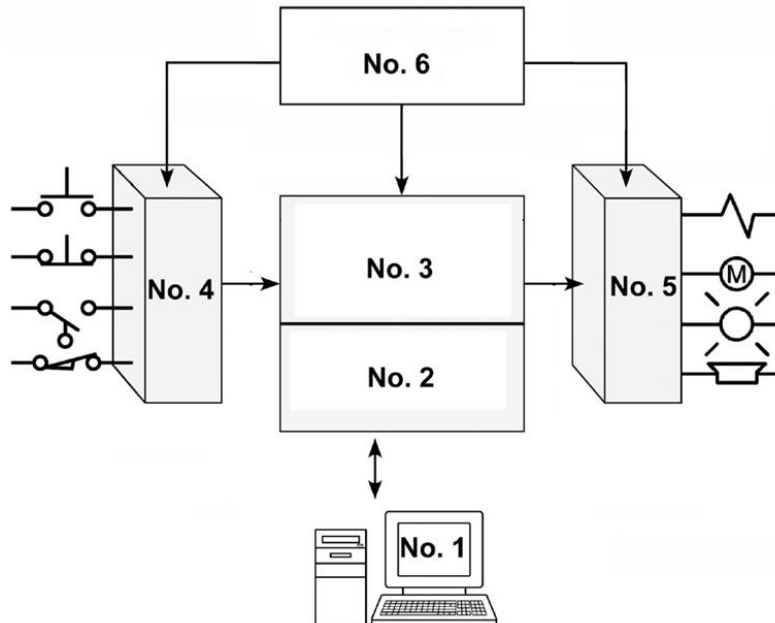

- A. processor module.
- B. power supply module.**
- C. input module.
- D. output module.

PTS: 1

# Chapter 001 - Programmable Logic Controllers (PLCs): An Overview **Key**

45. (p. 7) The diagram shown is a:

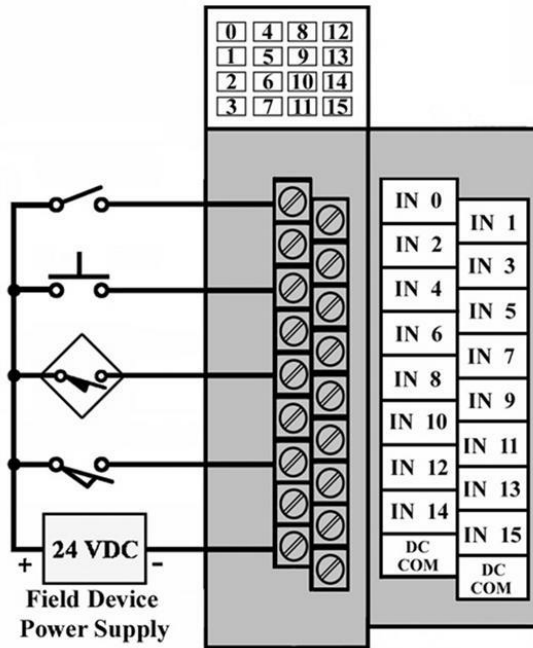

- A. relay schematic.
- B. ladder logic program.
- C. input module wiring.**
- D. output module wiring.

PTS: 1

## Chapter 001 - Programmable Logic Controllers (PLCs): An Overview **Key**

46. (p. 7) The voltage that would be present between the DC common and terminal 4 with the pushbutton open would be approximately:

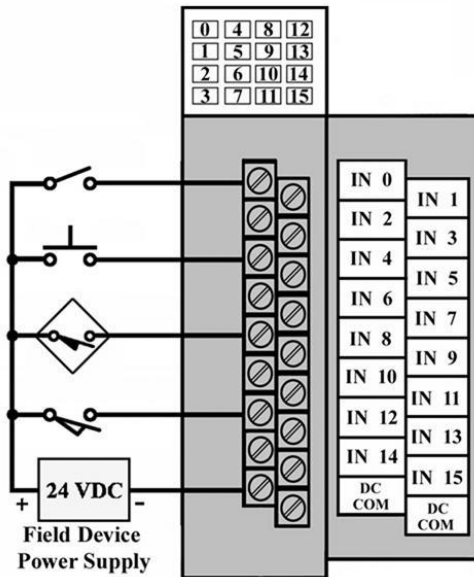

- A.** 0 volts.
- B. 6 volts.
- C. 12 volts.
- D. 24 volts.

PTS: 1

# Chapter 001 - Programmable Logic Controllers (PLCs): An Overview Key

47. (p. 7) The voltage that would be present between the DC common and terminal 4 with the pushbutton closed would be approximately:

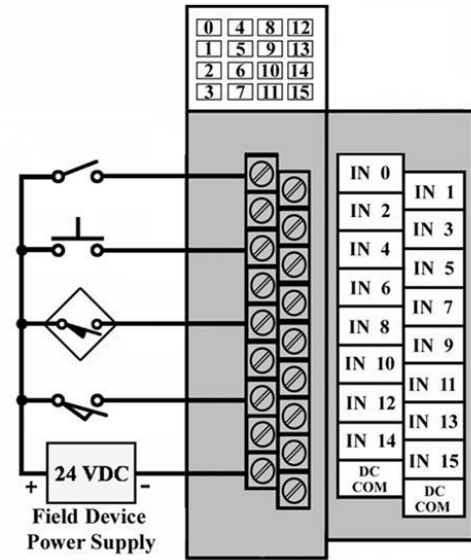

- A. 0 volts.
- B. 6 volts.
- C. 12 volts.
- D.** 24 volts.

PTS: 1

# Chapter 001 - Programmable Logic Controllers (PLCs): An Overview **Key**

48. (p. 7) The devices connected to the terminals would be classified as:

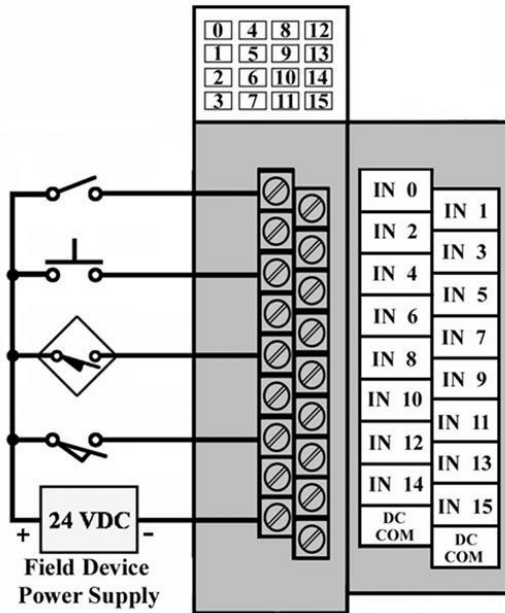

- A. field input devices.
- B. internal input instructions.
- C. field output devices.
- D. internal output instructions

PTS: 1



Chapter 001 - Programmable Logic Controllers (PLCs): An Overview **Key**

49. (p. 9) The diagram shown is that of a

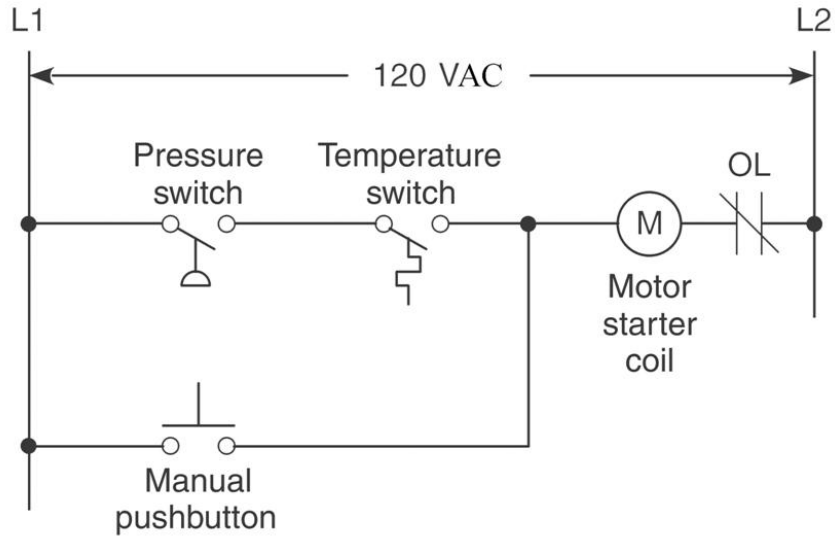

- A.** hardwired relay schematic.
- B. ladder logic program.
- C. input module schematic.
- D. output module schematic.

PTS: 1

Chapter 001 - Programmable Logic Controllers (PLCs): An Overview **Key**

50. (p. 8) In order to energize the starter coil:

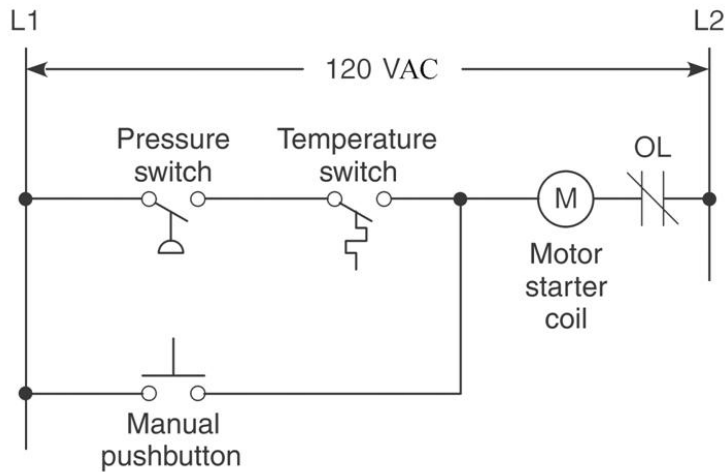

- A. the pressure switch, and the temperature switch, and the manual pushbutton must be closed.
- B. the pressure switch, or the temperature switch, or the manual pushbutton must be closed.
- C.** the pressure switch, and the temperature switch, or the manual pushbutton must be closed.
- D. All of the above.

PTS: 1

## Chapter 001 - Programmable Logic Controllers (PLCs): An Overview **Key**

51. (p. 10) The diagram shown is that of a:

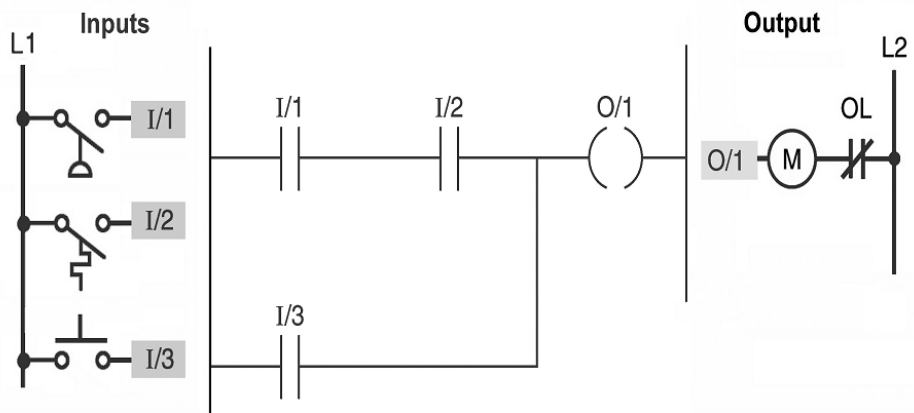

- A. relay schematic.
- B.** ladder logic program.
- C. input module wiring diagram.
- D. output module wiring diagram.

PTS: 1

## Chapter 001 - Programmable Logic Controllers (PLCs): An Overview **Key**

52. (p. 10) For there to be a continuous logic path from left to right across the rung:

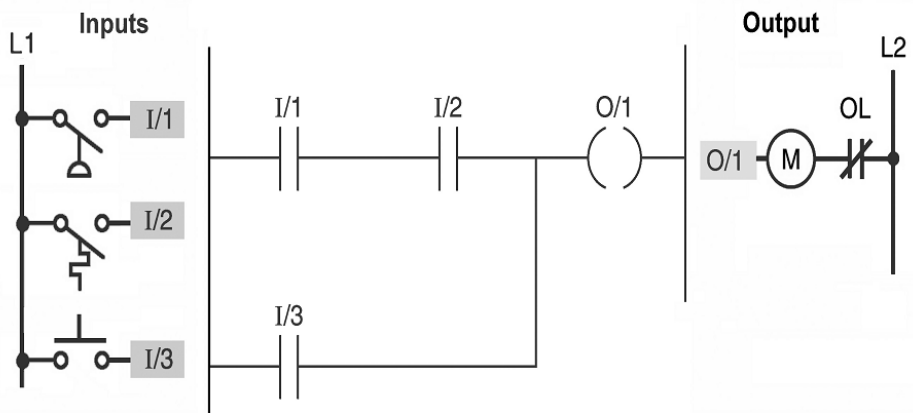

- A. I/1, I/2, and I/3 must all be at logic 1.
- B. I/1, I/2, and I/3 must all be at logic 0.
- C.** I/1 and I/2 or I/3 must be at logic 1.
- D. I/1 and I/2 or I/3 will be at logic 0.

PTS: 1

53. (p. 4) The PLC power supply module normally is rated to provide the power for:

- A. all field devices.
- B. input field devices only.
- C. output field devices only.
- D.** PLC backplane and I/O modules.

PTS: 1

54. (p. 5) Which module of the PLC is responsible for performing logical operations?

- A.** Processor
- B. Input
- C. Output
- D. Power supply

PTS: 1

## Chapter 001 - Programmable Logic Controllers (PLCs): An Overview **Key**

55. (p. 3) Which module of the PLC connects directly to field devices such as pilot lights, motor starters, and solenoids?

- A. Input
- B. Output**
- C. Power supply
- D. Memory

*PTS: 1*

56. (p. 4) I/Os are typical of small PLCs that come in one package with no separate removable units.

- A. Fixed**
- B. Modular
- C. Digital
- D. Analog

*PTS: 1*

57. (p. 7) PLC software that runs on a personal computer can be used to:

- A. write a PLC program.
- B. document a PLC program.
- C. monitor the control process.
- D. All of the above.**

*PTS: 1*

58. (p. 13) A control management PLC application normally requires a:

- A. micro-size PLC.
- B. small-size PLC.
- C. medium-size PLC.
- D. large-size PLC.**

*PTS: 1*

Chapter 001 - Programmable Logic Controllers (PLCs): An Overview **Key**

59. (p. 14) Which of the following is *not* a factor effecting the memory size needed for a particular PLC installation?

- A. Voltage rating of field devices
- B. Number of I/O points
- C. Size of control program
- D. Supervisory functions

*PTS: 1*