

Aircraft Structures

for Engineering Students

Fifth Edition

Solutions Manual

T. H. G. Megson

This page intentionally left blank

Solutions Manual

Solutions to Chapter 1 Problems

S.1.1

The principal stresses are given directly by Eqs (1.11) and (1.12) in which $\sigma_x = 80\text{N/mm}^2$, $\sigma_y = 0$ (or vice versa) and $\tau_{xy} = 45\text{N/mm}^2$. Thus, from Eq. (1.11)

$$\sigma_{\text{I}} = \frac{80}{2} + \frac{1}{2}\sqrt{80^2 + 4 \times 45^2}$$

i.e.

$$\sigma_{\text{I}} = 100.2 \text{ N/mm}^2$$

From Eq. (1.12)

$$\sigma_{\text{II}} = \frac{80}{2} - \frac{1}{2}\sqrt{80^2 + 4 \times 45^2}$$

i.e.

$$\sigma_{\text{II}} = -20.2 \text{ N/mm}^2$$

The directions of the principal stresses are defined by the angle θ in Fig. 1.8(b) in which θ is given by Eq. (1.10). Hence

$$\tan 2\theta = \frac{2 \times 45}{80 - 0} = 1.125$$

which gives

$$\theta = 24^\circ 11' \quad \text{and} \quad \theta = 114^\circ 11'$$

It is clear from the derivation of Eqs (1.11) and (1.12) that the first value of θ corresponds to σ_{I} while the second value corresponds to σ_{II} .

Finally, the maximum shear stress is obtained from either of Eqs (1.14) or (1.15). Hence from Eq. (1.15)

$$\tau_{\text{max}} = \frac{100.2 - (-20.2)}{2} = 60.2 \text{ N/mm}^2$$

and will act on planes at 45° to the principal planes.

S.1.2

The principal stresses are given directly by Eqs (1.11) and (1.12) in which $\sigma_x = 50 \text{ N/mm}^2$, $\sigma_y = -35 \text{ N/mm}^2$ and $\tau_{xy} = 40 \text{ N/mm}^2$. Thus, from Eq. (1.11)

$$\sigma_I = \frac{50 - 35}{2} + \frac{1}{2} \sqrt{(50 + 35)^2 + 4 \times 40^2}$$

i.e.

$$\sigma_I = 65.9 \text{ N/mm}^2$$

and from Eq. (1.12)

$$\sigma_{II} = \frac{50 - 35}{2} - \frac{1}{2} \sqrt{(50 + 35)^2 + 4 \times 40^2}$$

i.e.

$$\sigma_{II} = -50.9 \text{ N/mm}^2$$

From Fig. 1.8(b) and Eq. (1.10)

$$\tan 2\theta = \frac{2 \times 40}{50 + 35} = 0.941$$

which gives

$$\theta = 21^\circ 38' (\sigma_I) \quad \text{and} \quad \theta = 111^\circ 38' (\sigma_{II})$$

The planes on which there is no direct stress may be found by considering the triangular element of unit thickness shown in Fig. S.1.2 where the plane AC represents the plane on which there is no direct stress. For equilibrium of the element in a direction perpendicular to AC

$$0 = 50AB \cos \alpha - 35BC \sin \alpha + 40AB \sin \alpha + 40BC \cos \alpha \quad (i)$$

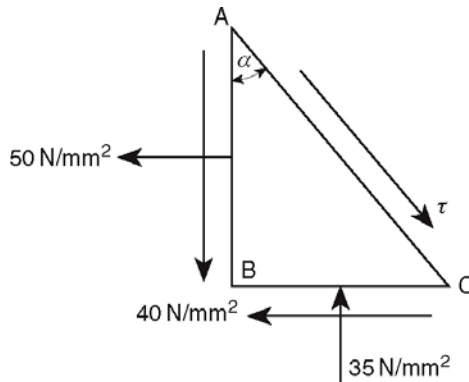

Fig. S.1.2

Dividing through Eq. (i) by $\cos \alpha$

$$0 = 50 \cos \alpha - 35 \tan \alpha \sin \alpha + 40 \sin \alpha + 40 \tan \alpha \cos \alpha$$

which, dividing through by $\cos \alpha$, simplifies to

$$0 = 50 - 35 \tan^2 \alpha + 80 \tan \alpha$$

from which

$$\tan \alpha = 2.797 \quad \text{or} \quad -0.511$$

Hence

$$\alpha = 70^\circ 21' \quad \text{or} \quad -27^\circ 5'$$

S.1.3

The construction of Mohr's circle for each stress combination follows the procedure described in Section 1.8 and is shown in Figs S.1.3(a)–(d).

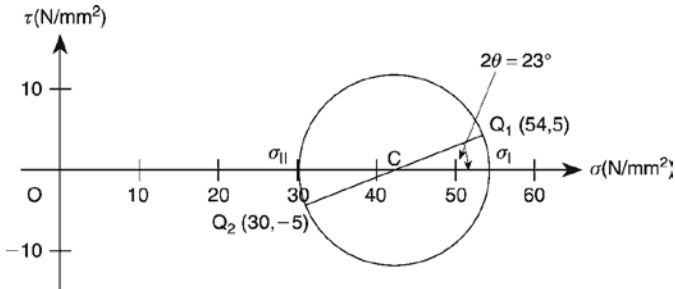

Fig. S.1.3(a)

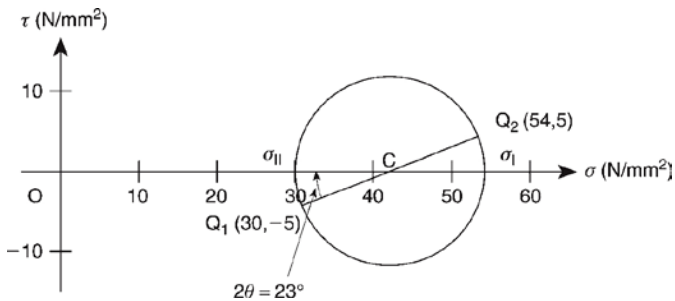

Fig. S.1.3(b)

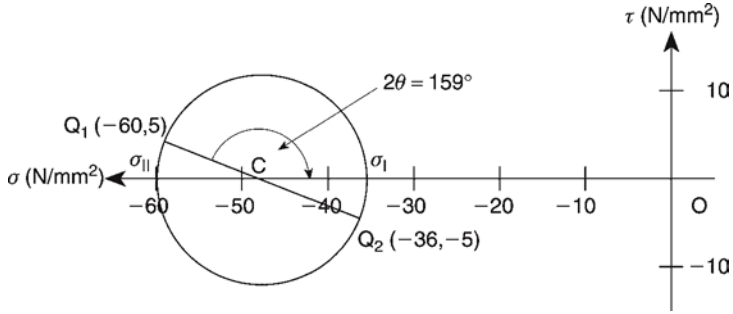

Fig. S.1.3(c)

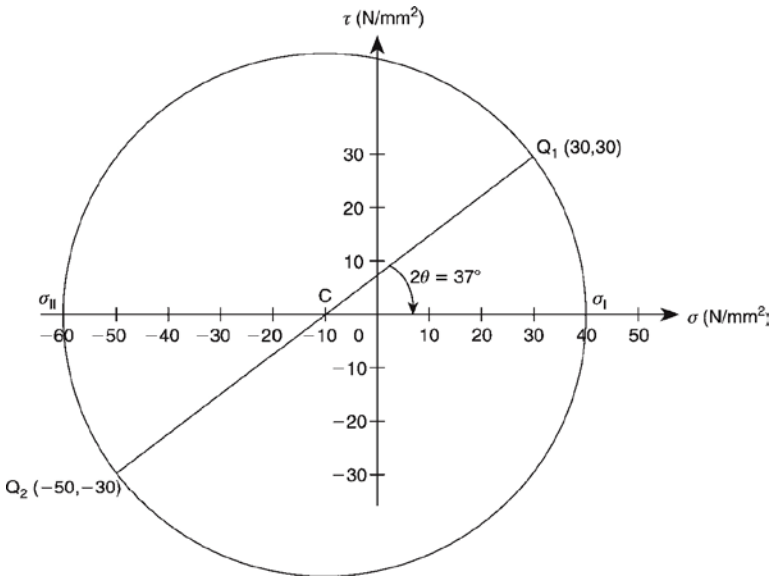

Fig. S.1.3(d)

S.1.4

The principal stresses at the point are determined, as indicated in the question, by transforming each state of stress into a $\sigma_x, \sigma_y, \tau_{xy}$ stress system. Clearly, in the first case $\sigma_x = 0, \sigma_y = 10 \text{ N/mm}^2, \tau_{xy} = 0$ (Fig. S.1.4(a)). The two remaining cases are transformed by considering the equilibrium of the triangular element ABC in Figs S.1.4(b), (c), (e) and (f). Thus, using the method described in Section 1.6 and the principle of superposition (see Section 5.9), the second stress system of

Figs S.1.4(b) and (c) becomes the σ_x , σ_y , τ_{xy} system shown in Fig. S.1.4(d) while

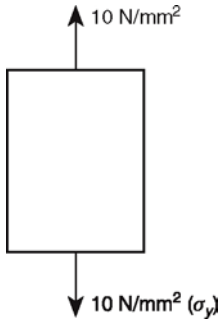

Fig. S.1.4(a)

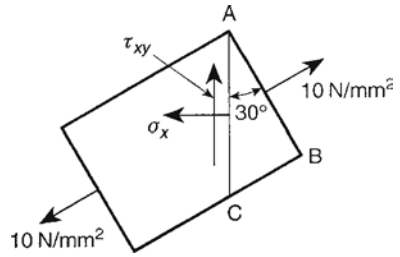

Fig. S.1.4(b)

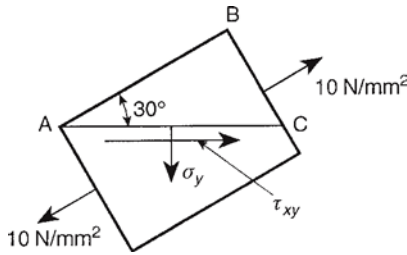

Fig. S.1.4(c)

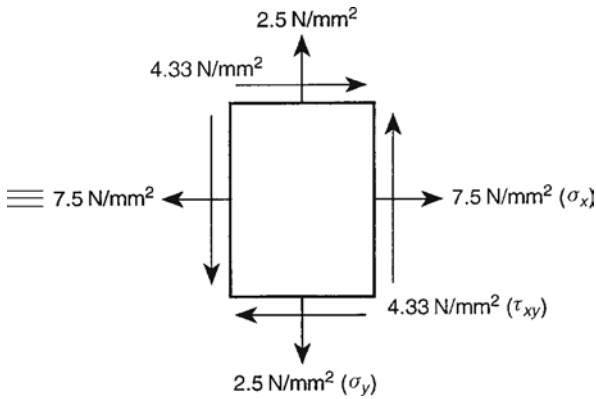

Fig. S.1.4(d)

the third stress system of Figs S.1.4(e) and (f) transforms into the $\sigma_x, \sigma_y, \tau_{xy}$ system of Fig. S.1.4(g).

Finally, the states of stress shown in Figs S.1.4(a), (d) and (g) are superimposed to give the state of stress shown in Fig. S.1.4(h) from which it can be seen that $\sigma_I = \sigma_{II} = 15\text{N/mm}^2$ and that the x and y planes are principal planes.

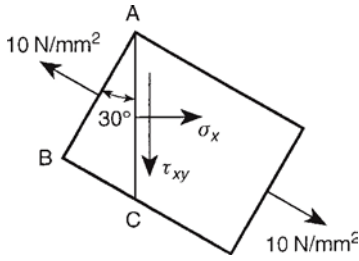

Fig. S.1.4(e)

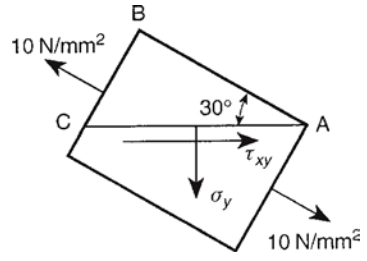

Fig. S.1.4(f)

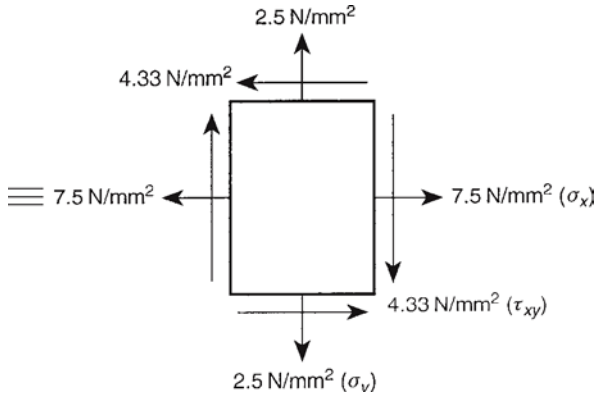

Fig. S.1.4(g)

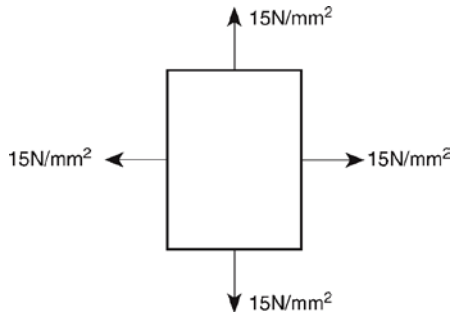

Fig. S.1.4(h)

S.1.5

The geometry of Mohr's circle of stress is shown in Fig. S.1.5 in which the circle is constructed using the method described in Section 1.8.

From Fig. S.1.5

$$\sigma_x = OP_1 = OB - BC + CP_1 \quad (i)$$

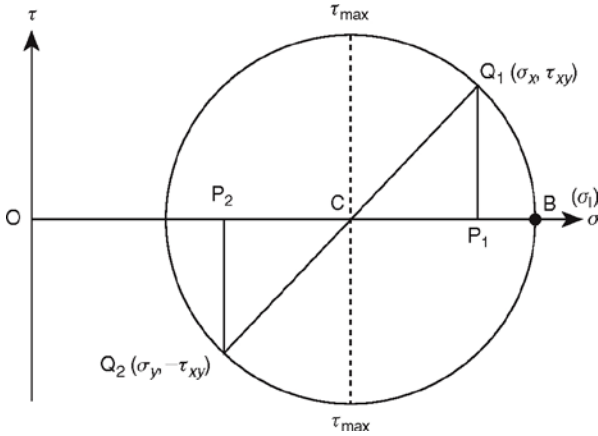

Fig. S.1.5

In Eq. (i) $OB = \sigma_1$, BC is the radius of the circle which is equal to τ_{\max} and $CP_1 = \sqrt{CQ_1^2 - Q_1P_1^2} = \sqrt{\tau_{\max}^2 - \tau_{xy}^2}$. Hence

$$\sigma_x = \sigma_1 - \tau_{\max} + \sqrt{\tau_{\max}^2 - \tau_{xy}^2}$$

Similarly

$$\sigma_y = OP_2 = OB - BC - CP_2 \text{ in which } CP_2 = CP_1$$

Thus

$$\sigma_y = \sigma_1 - \tau_{\max} - \sqrt{\tau_{\max}^2 - \tau_{xy}^2}$$

S.1.6

From bending theory the direct stress due to bending on the upper surface of the shaft at a point in the vertical plane of symmetry is given by

$$\sigma_x = \frac{My}{I} = \frac{25 \times 10^6 \times 75}{\pi \times 150^4 / 64} = 75 \text{ N/mm}^2$$

From the theory of the torsion of circular section shafts the shear stress at the same point is

$$\tau_{xy} = \frac{Tr}{J} = \frac{50 \times 10^6 \times 75}{\pi \times 150^4 / 32} = 75 \text{ N/mm}^2$$

12 Solutions Manual

Substituting these values in Eqs (1.11) and (1.12) in turn and noting that $\sigma_y = 0$

$$\sigma_I = \frac{75}{2} + \frac{1}{2}\sqrt{75^2 + 4 \times 75^2}$$

i.e.

$$\sigma_I = 121.4 \text{ N/mm}^2$$

$$\sigma_{II} = \frac{75}{2} - \frac{1}{2}\sqrt{75^2 + 4 \times 75^2}$$

i.e.

$$\sigma_{II} = -46.4 \text{ N/mm}^2$$

The corresponding directions as defined by θ in Fig. 1.8(b) are given by Eq. (1.10)

i.e.

$$\tan 2\theta = \frac{2 \times 75}{75 - 0} = 2$$

Hence

$$\theta = 31^\circ 43' (\sigma_I)$$

and

$$\theta = 121^\circ 43' (\sigma_{II})$$

S.1.7

The direct strains are expressed in terms of the stresses using Eqs (1.42), i.e.

$$\varepsilon_x = \frac{1}{E}[\sigma_x - \nu(\sigma_y + \sigma_z)] \quad (\text{i})$$

$$\varepsilon_y = \frac{1}{E}[\sigma_y - \nu(\sigma_x + \sigma_z)] \quad (\text{ii})$$

$$\varepsilon_z = \frac{1}{E}[\sigma_z - \nu(\sigma_x + \sigma_y)] \quad (\text{iii})$$

Then

$$e = \varepsilon_x + \varepsilon_y + \varepsilon_z = \frac{1}{E}[\sigma_x + \sigma_y + \sigma_z - 2\nu(\sigma_x + \sigma_y + \sigma_z)]$$

i.e.

$$e = \frac{(1-2\nu)}{E}(\sigma_x + \sigma_y + \sigma_z)$$

whence

$$\sigma_y + \sigma_z = \frac{Ee}{(1-2\nu)} - \sigma_x$$

Substituting in Eq. (i)

$$\varepsilon_x = \frac{1}{E} \left[\sigma_x - \nu \left(\frac{Ee}{1-2\nu} - \sigma_x \right) \right]$$

so that

$$E\varepsilon_x = \sigma_x(1+\nu) - \frac{\nu Ee}{1-2\nu}$$

Thus

$$\sigma_x = \frac{\nu Ee}{(1-2\nu)(1+\nu)} + \frac{E}{(1+\nu)} \varepsilon_x$$

or, since $G = E/2(1+\nu)$ (see Section 1.15)

$$\sigma_x = \lambda e + 2G\varepsilon_x$$

Similarly

$$\sigma_y = \lambda e + 2G\varepsilon_y$$

and

$$\sigma_z = \lambda e + 2G\varepsilon_z$$

S.1.8

The implication in this problem is that the condition of plane strain also describes the condition of plane stress. Hence, from Eqs (1.52)

$$\varepsilon_x = \frac{1}{E} (\sigma_x - \nu\sigma_y) \quad (\text{i})$$

$$\varepsilon_y = \frac{1}{E} (\sigma_y - \nu\sigma_x) \quad (\text{ii})$$

$$\gamma_{xy} = \frac{\tau_{xy}}{G} = \frac{2(1+\nu)}{E} \tau_{xy} \quad (\text{see Section 1.15}) \quad (\text{iii})$$

The compatibility condition for plane strain is

$$\frac{\partial^2 \gamma_{xy}}{\partial x \partial y} = \frac{\partial^2 \varepsilon_y}{\partial x^2} + \frac{\partial^2 \varepsilon_x}{\partial y^2} \quad (\text{see Section 1.11}) \quad (\text{iv})$$

Substituting in Eq. (iv) for ε_x , ε_y and γ_{xy} from Eqs (i)–(iii), respectively, gives

$$2(1+\nu) \frac{\partial^2 \tau_{xy}}{\partial x \partial y} = \frac{\partial^2}{\partial x^2} (\sigma_y - \nu\sigma_x) + \frac{\partial^2}{\partial y^2} (\sigma_x - \nu\sigma_y) \quad (\text{v})$$

14 **Solutions Manual**

Also, from Eqs (1.6) and assuming that the body forces X and Y are zero

$$\frac{\partial \sigma_x}{\partial x} + \frac{\partial \tau_{zy}}{\partial y} = 0 \quad \text{(vi)}$$

$$\frac{\partial \sigma_y}{\partial y} + \frac{\partial \tau_{xy}}{\partial x} = 0 \quad \text{(vii)}$$

Differentiating Eq. (vi) with respect to x and Eq. (vii) with respect to y and adding gives

$$\frac{\partial^2 \sigma_x}{\partial x^2} + \frac{\partial^2 \tau_{xy}}{\partial y \partial x} + \frac{\partial^2 \sigma_y}{\partial y^2} + \frac{\partial^2 \tau_{xy}}{\partial x \partial y} = 0$$

or

$$2 \frac{\partial^2 \tau_{xy}}{\partial x \partial y} = - \left(\frac{\partial^2 \sigma_x}{\partial x^2} + \frac{\partial^2 \sigma_y}{\partial y^2} \right)$$

Substituting in Eq. (v)

$$-(1 + \nu) \left(\frac{\partial^2 \sigma_x}{\partial x^2} + \frac{\partial^2 \sigma_y}{\partial y^2} \right) = \frac{\partial^2}{\partial x^2} (\sigma_y - \nu \sigma_x) + \frac{\partial^2}{\partial y^2} (\sigma_x - \nu \sigma_y)$$

so that

$$-(1 + \nu) \left(\frac{\partial^2 \sigma_x}{\partial x^2} + \frac{\partial^2 \sigma_y}{\partial y^2} \right) = \frac{\partial^2 \sigma_y}{\partial x^2} + \frac{\partial^2 \sigma_x}{\partial y^2} - \nu \left(\frac{\partial^2 \sigma_x}{\partial x^2} + \frac{\partial^2 \sigma_y}{\partial y^2} \right)$$

which simplifies to

$$\frac{\partial^2 \sigma_y}{\partial x^2} + \frac{\partial^2 \sigma_x}{\partial y^2} + \frac{\partial^2 \sigma_x}{\partial x^2} + \frac{\partial^2 \sigma_y}{\partial y^2} = 0$$

or

$$\left(\frac{\partial^2}{\partial x^2} + \frac{\partial^2}{\partial y^2} \right) (\sigma_x + \sigma_y) = 0$$

S.1.9

Suppose that the load in the steel bar is P_{st} and that in the aluminium bar is P_{al} . Then, from equilibrium

$$P_{st} + P_{al} = P \quad \text{(i)}$$

From Eq. (1.40)

$$\epsilon_{st} = \frac{P_{st}}{A_{st} E_{st}} \quad \epsilon_{al} = \frac{P_{al}}{A_{al} E_{al}}$$

Since the bars contract by the same amount

$$\frac{P_{st}}{A_{st}E_{st}} = \frac{P_{al}}{A_{al}E_{al}} \quad (\text{ii})$$

Solving Eqs (i) and (ii)

$$P_{st} = \frac{A_{st}E_{st}}{A_{st}E_{st} + A_{al}E_{al}} P \quad P_{al} = \frac{A_{al}E_{al}}{A_{st}E_{st} + A_{al}E_{al}} P$$

from which the stresses are

$$\sigma_{st} = \frac{E_{st}}{A_{st}E_{st} + A_{al}E_{al}} P \quad \sigma_{al} = \frac{E_{al}}{A_{st}E_{st} + A_{al}E_{al}} P \quad (\text{iii})$$

The areas of cross-section are

$$A_{st} = \frac{\pi \times 75^2}{4} = 4417.9 \text{ mm}^2 \quad A_{al} = \frac{\pi(100^2 - 75^2)}{4} = 3436.1 \text{ mm}^2$$

Substituting in Eq. (iii) we have

$$\sigma_{st} = \frac{10^6 \times 200000}{(4417.9 \times 200000 + 3436.1 \times 80000)} = 172.6 \text{ N/mm}^2 \text{ (compression)}$$

$$\sigma_{al} = \frac{10^6 \times 80000}{(4417.9 \times 200000 + 3436.1 \times 80000)} = 69.1 \text{ N/mm}^2 \text{ (compression)}$$

Due to the decrease in temperature in which no change in length is allowed the strain in the steel is $\alpha_{st}T$ and that in the aluminium is $\alpha_{al}T$. Therefore due to the decrease in temperature

$$\sigma_{st} = E_{st}\alpha_{st}T = 200000 \times 0.000012 \times 150 = 360.0 \text{ N/mm}^2 \text{ (tension)}$$

$$\sigma_{al} = E_{al}\alpha_{al}T = 80000 \times 0.000005 \times 150 = 60.0 \text{ N/mm}^2 \text{ (tension)}$$

The final stresses in the steel and aluminium are then

$$\sigma_{st}(\text{total}) = 360.0 - 172.6 = 187.4 \text{ N/mm}^2 \text{ (tension)}$$

$$\sigma_{al}(\text{total}) = 60.0 - 69.1 = -9.1 \text{ N/mm}^2 \text{ (compression)}$$

S.1.10

The principal strains are given directly by Eqs (1.69) and (1.70). Thus

$$\varepsilon_1 = \frac{1}{2}(-0.002 + 0.002) + \frac{1}{\sqrt{2}} \sqrt{(-0.002 + 0.002)^2 + (+0.002 + 0.002)^2}$$

16 Solutions Manual

i.e.

$$\varepsilon_{\text{I}} = +0.00283$$

Similarly

$$\varepsilon_{\text{II}} = -0.00283$$

The principal directions are given by Eq. (1.71), i.e.

$$\tan 2\theta = \frac{2(-0.002) + 0.002 - 0.002}{0.002 + 0.002} = -1$$

Hence

$$2\theta = -45^\circ \text{ or } +135^\circ$$

and

$$\theta = -22.5^\circ \text{ or } +67.5^\circ$$

S.1.11

The principal strains at the point **P** are determined using Eqs (1.69) and (1.70). Thus

$$\varepsilon_{\text{I}} = \left[\frac{1}{2}(-222 + 45) + \frac{1}{\sqrt{2}} \sqrt{(-222 + 213)^2 + (-213 - 45)^2} \right] \times 10^{-6}$$

i.e.

$$\varepsilon_{\text{I}} = 94.0 \times 10^{-6}$$

Similarly

$$\varepsilon_{\text{II}} = -217.0 \times 10^{-6}$$

The principal stresses follow from Eqs (1.67) and (1.68). Hence

$$\sigma_{\text{I}} = \frac{31000}{1 - (0.2)^2} (94.0 - 0.2 \times 271.0) \times 10^{-6}$$

i.e.

$$\sigma_{\text{I}} = 1.29 \text{ N/mm}^2$$

Similarly

$$\sigma_{\text{II}} = -814 \text{ N/mm}^2$$

Since **P** lies on the neutral axis of the beam the direct stress due to bending is zero. Therefore, at **P**, $\sigma_x = 7 \text{ N/mm}^2$ and $\sigma_y = 0$. Now subtracting Eq. (1.12) from (1.11)

$$\sigma_{\text{I}} - \sigma_{\text{II}} = \sqrt{\sigma_x^2 + 4\tau_{xy}^2}$$

i.e.

$$1.29 + 8.14 = \sqrt{7^2 + 4\tau_{xy}^2}$$

from which $\tau_{xy} = 3.17 \text{ N/mm}^2$.

The shear force at **P** is equal to Q so that the shear stress at **P** is given by

$$\tau_{xy} = 3.17 = \frac{3Q}{2 \times 150 \times 300}$$

from which

$$Q = 95\,100 \text{ N} = 95.1 \text{ kN}.$$

Solutions to Chapter 2 Problems

S.2.1

The stress system applied to the plate is shown in Fig. S.2.1. The origin, **O**, of the axes may be chosen at any point in the plate; let **P** be the point whose coordinates are (2, 3).

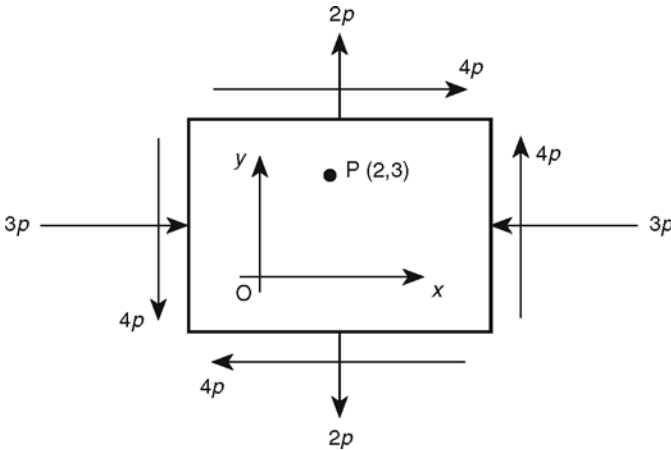

Fig. S.2.1

From Eqs (1.42) in which $\sigma_z = 0$

$$\varepsilon_x = -\frac{3p}{E} - \nu \frac{2p}{E} = -\frac{3.5p}{E} \tag{i}$$

$$\varepsilon_y = -\frac{3p}{E} - \nu \frac{3p}{E} = -\frac{2.75p}{E} \tag{ii}$$

Hence, from Eqs (1.27)

$$\frac{\partial u}{\partial x} = -\frac{3.5p}{E} \text{ so that } u = -\frac{3.5p}{E}x + f_1(y) \tag{iii}$$

18 **Solutions Manual**

where $f_1(y)$ is a function of y . Also

$$\frac{\partial v}{\partial y} = \frac{2.75p}{E} \text{ so that } v = -\frac{2.75p}{E}y + f_2(x) \tag{iv}$$

in which $f_2(x)$ is a function of x .

From the last of Eqs (1.52) and Eq. (1.28)

$$\gamma_{xy} = \frac{4p}{G} = \frac{\partial v}{\partial x} + \frac{\partial u}{\partial y} = \frac{\partial f_2(x)}{\partial x} + \frac{\partial f_1(y)}{\partial y} \text{ (from Eqs (iv) and (iii))}$$

Suppose

$$\frac{\partial f_1(y)}{\partial y} = A$$

then

$$f_1(y) = Ay + B \tag{v}$$

in which A and B are constants.

Similarly, suppose

$$\frac{\partial f_2(x)}{\partial x} = C$$

then

$$f_2(x) = Cx + D \tag{vi}$$

in which C and D are constants.

Substituting for $f_1(y)$ and $f_2(x)$ in Eqs (iii) and (iv) gives

$$u = -\frac{3.5p}{E}x + Ay + B \tag{vii}$$

and

$$v = \frac{2.75p}{E}y + Cx + D \tag{viii}$$

Since the origin of the axes is fixed in space it follows that when $x = y = 0$, $u = v = 0$. Hence, from Eqs (vii) and (viii), $B = D = 0$. Further, the direction of Ox is fixed in space so that, when $y = 0$, $\partial v / \partial x = 0$. Therefore, from Eq. (viii), $C = 0$. Thus, from Eqs (1.28) and (vii), when $x = 0$.

$$\frac{\partial u}{\partial y} = \frac{4p}{G} = A$$

Eqs (vii) and (viii) now become

$$u = -\frac{3.5p}{E}x + \frac{4p}{G}y \tag{ix}$$

$$v = \frac{2.75p}{E} y \quad (\text{x})$$

From Eq. (1.50), $G=E/2(1+\nu)=E/2.5$ and Eq. (ix) becomes

$$u = \frac{P}{E} (-3.5 + 10y) \quad (\text{xi})$$

At the point (2, 3)

$$u = \frac{23p}{E} \quad (\text{from Eq. (xi)})$$

and

$$v = \frac{8.25p}{E} \quad (\text{from Eq. (x)})$$

The point **P** therefore moves at an angle α to the x axis given by

S.2.2

An Airy stress function, ϕ , is defined by the equations (Eqs (2.8)):

$$\sigma_x = \frac{\partial^2 \phi}{\partial y^2} \quad \sigma_y = \frac{\partial^2 \phi}{\partial x^2} \quad \tau_{xy} = -\frac{\partial^2 \phi}{\partial x \partial y}$$

and has a final form which is determined by the boundary conditions relating to a particular problem.

Since

$$\phi = Ay^3 + By^3x + Cyx \quad (\text{i})$$

$$\frac{\partial^4 \phi}{\partial x^4} = 0 \quad \frac{\partial^4 \phi}{\partial y^4} = 0 \quad \frac{\partial^4 \phi}{\partial x^2 \partial y^2} = 0$$

and the biharmonic equation (2.9) is satisfied. Further

$$\sigma_x = \frac{\partial^2 \phi}{\partial y^2} = 6Ay + 6Byx \quad (\text{ii})$$

$$\sigma_y = \frac{\partial^2 \phi}{\partial x^2} = 0 \quad (\text{iii})$$

$$\tau_{xy} = -\frac{\partial^2 \phi}{\partial x \partial y} = -3By^2 - C \quad (\text{iv})$$

The distribution of shear stress in a rectangular section beam is parabolic and is zero at the upper and lower surfaces. Hence, when $y = \pm d/2$, $\tau_{xy} = 0$. Thus, from Eq. (iv)

$$B = \frac{-4C}{3d^2} \quad (\text{v})$$

20 **Solutions Manual**

The resultant shear force at any section of the beam is $-P$. Therefore

$$\int_{-d/2}^{d/2} \tau_{xy} t \, dy = -P$$

Substituting for τ_{xy} from Eq. (iv)

$$\int_{-d/2}^{d/2} (-3By^2 - C)t \, dy = -P$$

which gives

$$2t \left(\frac{Bd^3}{8} + \frac{Cd}{2} \right) = P$$

Substituting for B from Eq. (v) gives

$$C = \frac{3P}{2td} \tag{vi}$$

It now follows from Eqs (v) and (vi) that

$$B = \frac{-2P}{td^3} \tag{vii}$$

At the free end of the beam where $x = l$ the bending moment is zero and thus $\sigma_x = 0$ for any value of y . Therefore, from Eq. (ii)

$$6A + 6Bl = 0$$

whence

$$A = \frac{2Pl}{td^3} \tag{viii}$$

Then, from Eq. (ii)

$$\sigma_x = \frac{12Pl}{td^3} y - \frac{12P}{td^3} xy$$

or

$$\sigma_x = \frac{12P(l-x)}{td^3} y \tag{ix}$$

Equation (ix) is the direct stress distribution at any section of the beam given by simple bending theory, i.e.

$$\sigma_x = \frac{My}{I}$$

where $M = P(l-x)$ and $I = td^3/12$.

The shear stress distribution given by Eq. (iv) is

$$\tau_{xy} = \frac{6P}{td^3} y^2 - \frac{3P}{2td}$$

or

$$\tau_{xy} = \frac{6P}{td^3} \left(y^2 - \frac{d^2}{4} \right) \quad (x)$$

Equation (x) is identical to that derived from simple bending theory and may be found in standard texts on stress analysis, strength of materials, etc.

S.2.3

The stress function is

$$\phi = \frac{w}{20h^3} (15h^2x^2y - 5x^2y^3 - 2h^2y^3 + y^5)$$

Then

$$\frac{\partial^2 \phi}{\partial x^2} = \frac{w}{20h^3} (30h^2y - 10y^3) = \sigma_y$$

$$\frac{\partial^2 \phi}{\partial y^2} = \frac{w}{20h^3} (-30x^2y - 12h^2y + 20y^3) = \sigma_x$$

$$\frac{\partial^2 \phi}{\partial x \partial y} = \frac{w}{20h^3} (30h^2x - 30xy^2) = -\tau_{xy}$$

$$\frac{\partial^4 \phi}{\partial x^4} = 0$$

$$\frac{\partial^4 \phi}{\partial y^4} = \frac{w}{20h^3} (120y)$$

$$\frac{\partial^4 \phi}{\partial x^2 \partial y^2} = \frac{w}{20h^3} (-60y)$$

Substituting in Eq. (2.9)

$$\nabla^4 \phi = 0$$

so that the stress function satisfies the biharmonic equation.

The boundary conditions are as follows:

- At $y = h$, $\sigma_y = w$ and $\tau_{xy} = 0$ which are satisfied.
- At $y = -h$, $\sigma_y = -w$ and $\tau_{xy} = 0$ which are satisfied.
- At $x = 0$, $\sigma_x = w/20h^3 (-12h^2y + 20y^3) \neq 0$.

Also

$$\begin{aligned} \int_{-h}^h \sigma_x \, dy &= \frac{w}{20h^3} \int_{-h}^h (-12h^2y + 20y^3) \, dy \\ &= \frac{w}{20h^3} [-6h^2y^2 + 5y^4]_{-h}^h \\ &= 0 \end{aligned}$$

i.e. no resultant force.

Finally

$$\begin{aligned}\int_{-h}^h \sigma_x y \, dy &= \frac{w}{20h^3} \int_{-h}^h (-12h^2 y^2 + 20y^4) \, dy \\ &= \frac{w}{20h^3} [-4h^2 y^3 + 4y^5]_{-h}^h \\ &= 0\end{aligned}$$

i.e. no resultant moment.

S.2.4

The Airy stress function is

$$\phi = \frac{p}{120d^3} [5(x^3 - l^2 x)(y + d)^2 (y - 2d) - 3yx(y^2 - d^2)^2]$$

Then

$$\frac{\partial^4 \phi}{\partial x^4} = 0 \quad \frac{\partial^4 \phi}{\partial y^4} = -\frac{3pxy}{d^3} \quad \frac{\partial^4 \phi}{\partial x^2 \partial y^2} = \frac{3pxy}{2d^3}$$

Substituting these values in Eq. (2.9) gives

$$0 + 2 \times \frac{3pxy}{2d^3} - \frac{3pxy}{d^3} = 0$$

Therefore, the biharmonic equation (2.9) is satisfied.

The direct stress, σ_x , is given by (see Eqs (2.8))

$$\sigma_x = \frac{\partial^2 \phi}{\partial y^2} = \frac{px}{20d^3} [5y(x^2 - l^2) - 10y^3 + 6d^2 y]$$

When $x = 0$, $\sigma_x = 0$ for all values of y . When $x = l$

$$\sigma_x = \frac{pl}{20d^3} (-10y^3 + 6d^2 y)$$

and the total end load = $\int_{-d}^d \sigma_x \, 1 \, dy$

$$= \frac{pl}{20d^3} \int_{-d}^d (-10y^3 + 6d^2 y) \, dy = 0$$

Thus the stress function satisfies the boundary conditions for axial load in the x direction.

Also, the direct stress, σ_y , is given by (see Eqs (2.8))

$$\sigma_y = \frac{\partial^2 \phi}{\partial x^2} = \frac{px}{4d^3} (y^3 - 3yd^2 - 2d^3)$$

When $x = 0$, $\sigma_y = 0$ for all values of y . Also at any section x where $y = -d$

$$\sigma_y = \frac{px}{4d^3}(-d^3 + 3d^3 - 2d^3) = 0$$

and when $y = +d$

$$\sigma_y = \frac{px}{4d^3}(d^3 - 3d^3 - 2d^3) = -px$$

Thus, the stress function satisfies the boundary conditions for load in the y direction.

The shear stress, τ_{xy} , is given by (see Eqs (2.8))

$$\tau_{xy} = -\frac{\partial^2 \phi}{\partial x \partial y} = -\frac{p}{40d^3}[5(3x^2 - l^2)(y^2 - d^2) - 5y^4 + 6y^2d^2 - d^4]$$

When $x = 0$

$$\tau_{xy} = -\frac{p}{40d^3}[-5l^2(y^2 - d^2) - 5y^4 + 6y^2d^2 - d^4]$$

so that, when $y = \pm d$, $\tau_{xy} = 0$. The resultant shear force on the plane $x = 0$ is given by

$$\int_{-d}^d \tau_{xy} \, dy = -\frac{p}{40d^3} \int_{-d}^d [-5l^2(y^2 - d^2) - 5y^4 + 6y^2d^2 - d^4] \, dy = -\frac{pl^2}{6}$$

From Fig. P.2.4 and taking moments about the plane $x = l$,

$$\tau_{xy}(x=0) \, 12dl = \frac{1}{2} \, pl \, \frac{2}{3} \, l$$

i.e.

$$\tau_{xy}(x=0) = \frac{pl^2}{6d}$$

and the shear force is $pl^2/6$.

Thus, although the resultant of the Airy stress function shear stress has the same magnitude as the equilibrating shear force it varies through the depth of the beam whereas the applied equilibrating shear stress is constant. A similar situation arises on the plane $x = l$.

S.2.5

The stress function is

$$\phi = \frac{w}{40bc^3}(-10c^3x^2 - 15c^2x^2y + 2c^2y^3 + 5x^2y^3 - y^5)$$

24 **Solutions Manual**

Then

$$\frac{\partial^2 \phi}{\partial y^2} = \frac{w}{40bc^3} (12c^2 y + 30x^2 y - 20y^3) = \sigma_x$$

$$\frac{\partial^2 \phi}{\partial x^2} = \frac{w}{40bc^3} (-20c^3 - 30c^2 y + 10y^3) = \sigma_y$$

$$\frac{\partial^2 \phi}{\partial x \partial y} = \frac{w}{40bc^3} (-30c^2 x + 30xy^2) = -\tau_{xy}$$

$$\frac{\partial^4 \phi}{\partial x^4} = 0$$

$$\frac{\partial^4 \phi}{\partial y^4} = \frac{w}{40bc^3} (-120y)$$

$$\frac{\partial^4 \phi}{\partial x^2 \partial y^2} = \frac{w}{40bc^3} (60y)$$

Substituting in Eq. (2.9)

$$\nabla^4 \phi = 0$$

so that the stress function satisfies the biharmonic equation.

On the boundary, $y = +c$

$$\sigma_y = -\frac{w}{b} \tau_{xy} = 0$$

At $y = -c$

$$\sigma_y = 0 \quad \tau_{xy} = 0$$

At $x = 0$

$$\sigma_x = \frac{w}{40bc^3} (12c^2 y - 20y^3)$$

Then

$$\begin{aligned} \int_{-c}^c \sigma_x \, dy &= \frac{w}{40bc^3} \int_{-c}^c (12c^2 y - 20y^3) \, dy \\ &= \frac{w}{40bc^3} [6c^2 y^2 - 5y^4]_{-c}^c \\ &= 0 \end{aligned}$$

i.e. the direct stress distribution at the end of the cantilever is self-equilibrating.

The axial force at any section is

$$\begin{aligned} \int_{-c}^c \sigma_x \, dy &= \frac{w}{40bc^3} \int_{-c}^c (12c^2 y + 30x^2 y - 20y^3) \, dy \\ &= \frac{w}{40bc^3} [6c^2 y^2 + 15x^2 y^2 - 5y^4]_{-c}^c \\ &= 0 \end{aligned}$$

i.e. no axial force at any section of the beam.

The bending moment at $x=0$ is

$$\begin{aligned}\int_{-c}^c \sigma_x y \, dy &= \frac{w}{40bc^3} \int_{-c}^c (12c^2 y^2 - 20y^4) \, dy \\ &= \frac{w}{40bc^3} [4c^2 y^3 - 4y^5]_{-c}^c = 0\end{aligned}$$

i.e. the beam is a cantilever beam under a uniformly distributed load of w /unit area with a self-equilibrating stress application at $x=0$.

S.2.6

From physics, the strain due to a temperature rise T in a bar of original length L_0 and final length L is given by

$$\varepsilon = \frac{L - L_0}{L_0} = \frac{L_0(1 + \alpha T) - L_0}{L_0} = \alpha T$$

Thus for the isotropic sheet, Eqs (1.52) become

$$\begin{aligned}\varepsilon_x &= \frac{1}{E}(\sigma_x - \nu\sigma_y) + \alpha T \\ \varepsilon_y &= \frac{1}{E}(\sigma_y - \nu\sigma_x) + \alpha T\end{aligned}$$

Also, from the last of Eqs (1.52) and (1.50)

$$\gamma_{xy} = \frac{2(1+\nu)}{E} \tau_{xy}$$

Substituting in Eq. (1.21)

$$\frac{2(1+\nu)}{E} \frac{\partial^2 \tau_{xy}}{\partial x \partial y} = \frac{1}{E} \left(\frac{\partial^2 \sigma_y}{\partial x^2} - \nu \frac{\partial^2 \sigma_x}{\partial x^2} \right) + \alpha \frac{\partial^2 T}{\partial x^2} + \frac{1}{E} \left(\frac{\partial^2 \sigma_x}{\partial y^2} - \nu \frac{\partial^2 \sigma_y}{\partial y^2} \right) + \alpha \frac{\partial^2 T}{\partial y^2}$$

or

$$2(1+\nu) \frac{\partial^2 \tau_{xy}}{\partial x \partial y} = \frac{\partial^2 \sigma_y}{\partial x^2} + \frac{\partial^2 \sigma_x}{\partial y^2} - \nu \frac{\partial^2 \sigma_x}{\partial x^2} - \nu \frac{\partial^2 \sigma_y}{\partial y^2} + E\alpha \nabla^2 T \quad (i)$$

From Eqs (1.6) and assuming body forces $X=Y=0$

$$\frac{\partial^2 \tau_{xy}}{\partial y \partial x} = -\frac{\partial^2 \sigma_x}{\partial x^2} \quad \frac{\partial^2 \tau_{xy}}{\partial x \partial y} = -\frac{\partial^2 \sigma_y}{\partial y^2}$$

Hence

$$2 \frac{\partial^2 \tau_{xy}}{\partial x \partial y} = -\frac{\partial^2 \sigma_x}{\partial x^2} - \frac{\partial^2 \sigma_y}{\partial y^2}$$

and

$$2\nu \frac{\partial^2 \tau_{xy}}{\partial x \partial y} = -\nu \frac{\partial^2 \sigma_x}{\partial x^2} - \nu \frac{\partial^2 \sigma_y}{\partial y^2}$$

Substituting in Eq. (i)

$$-\frac{\partial^2 \sigma_x}{\partial x^2} - \frac{\partial^2 \sigma_y}{\partial y^2} = \frac{\partial^2 \sigma_y}{\partial x^2} + \frac{\partial^2 \sigma_x}{\partial y^2} + E\alpha \nabla^2 T$$

Thus

$$\left(\frac{\partial^2}{\partial x^2} + \frac{\partial^2}{\partial y^2} \right) (\sigma_x + \sigma_y) + E\alpha \nabla^2 T = 0$$

and since

$$\sigma_x = \frac{\partial^2 \phi}{\partial y^2} \quad \sigma_y = \frac{\partial^2 \phi}{\partial x^2} \quad (\text{see Eqs (2.8)})$$

$$\left(\frac{\partial^2}{\partial x^2} + \frac{\partial^2}{\partial y^2} \right) \left(\frac{\partial^2 \phi}{\partial y^2} + \frac{\partial^2 \phi}{\partial x^2} \right) + E\alpha \nabla^2 T = 0$$

or

$$\nabla^2 (\nabla^2 \phi + E\alpha T) = 0$$

S.2.7

The stress function is

$$\phi = \frac{3Qxy}{4a} - \frac{Qxy^3}{4a^3}$$

Then

$$\begin{aligned} \frac{\partial^2 \phi}{\partial x^2} &= 0 = \sigma_y \\ \frac{\partial^2 \phi}{\partial y^2} &= -\frac{3Qxy}{2a^3} = \sigma_x \\ \frac{\partial^2 \phi}{\partial x \partial y} &= \frac{3Q}{4a} - \frac{3Qy^2}{4a^3} = -\tau_{xy} \end{aligned}$$

Also

$$\frac{\partial^4 \phi}{\partial x^4} = 0 \quad \frac{\partial^4 \phi}{\partial y^4} = 0 \quad \frac{\partial^4 \phi}{\partial x^2 \partial y^2} = 0$$

so that Eq. (2.9), the biharmonic equation, is satisfied.

When $x = a$, $\sigma_x = -3Qy/2a^2$, i.e. linear.

Then, when

$$y = 0 \quad \sigma_x = 0$$

$$y = -a \quad \sigma_x = \frac{3Q}{2a}$$

$$y = +a \quad \sigma_x = \frac{-3Q}{2a}$$

Also, when $x = -a$, $\sigma_x = 3Qy/2a^2$, i.e. linear and when

$$y = 0 \quad \sigma_x = 0$$

$$y = -a \quad \sigma_x = \frac{-3Q}{2a}$$

$$y = +a \quad \sigma_x = \frac{3Q}{2a}$$

The shear stress is given by (see above)

$$\tau_{xy} = -\frac{3Q}{4a} \left(1 - \frac{y^2}{a^2} \right), \text{ i.e. parabolic}$$

so that, when $y = \pm a$, $\tau_{xy} = 0$ and when $y = 0$, $\tau_{xy} = -3Q/4a$.

The resultant shear force at $x = \pm a$ is

$$= \int_{-a}^a -\frac{3Q}{4a} \left(1 - \frac{y^2}{a^2} \right) dy$$

i.e.

$$SF = Q.$$

The resultant bending moment at $x = \pm a$ is

$$\begin{aligned} &= \int_{-a}^a \sigma_x y \, dy \\ &= \int_{-a}^a \frac{3Qay^2}{2a^3} \, dy \end{aligned}$$

i.e.

$$BM = -Qa$$

Aircraft Structures for Engineering Students 5th Edition Megson Solutions Manual

Full Download: <http://alibabadownload.com/product/aircraft-structures-for-engineering-stu>